

A MULTI-OBJECTIVE FRAMEWORK FOR ENVIRONMENTAL MANAGEMENT USING GOAL PROGRAMMING*

DEMETRIOS PANAGIOTAKOPOULOS, PH.D.

Assistant Professor, Civil Engineering

Department of Civil Engineering and Applied Mechanics

McGill University

Montreal, Canada

ABSTRACT

The scope of environmental management is to reach as much as possible a socially acceptable balance between economic benefits and resulting environmental quality; such a balance is defined in terms of politically established criteria and goals. Environmental management should also be concerned with integrating the often conflicting sub-goals of the economic, environmental, and technological components of the economic-environmental system into a multiple objective for guiding the development and evaluation of alternative policies. This paper presents a prescriptive framework for environmental management at the regional level which allows for a sufficiently realistic representation of the total system, deals systematically with multiple objectives through goal programming optimization techniques, and suggests an effective interaction between the decision-maker and the analyst for devising compromises among conflicting objectives. This is designed as an improvement over the ad hoc trial-and-error analysis based on trade-off relations. In essence, the procedure outlined here is directed toward establishing the economic-growth/environmental-quality possibility frontier of a region.

The Environmental Management Problem

The realization that there exists a limit to the capacity of the environment of a site or region to carry undesirable waste products, which almost always accompany the benefit generating productive and consumptive activities, has

* This work was supported by a grant to the author from the National Research Council of Canada and the Department of Education of Quebec.

given rise to the need for environmental, or waste, management. The scope of environmental management is to come as close as possible to a socially acceptable balance between generated benefits and resulting environmental quality, which often implies a control on economic growth. From the viewpoint of a regional environmental management authority (henceforth referred to as the Decision Maker—DM), the economic-environmental system should be balanced with respect to the operating levels of waste generating economic activities, the quality of every environmental form, and the authority's operating budget.

In the last decade, quite a few waste management efforts have been launched; their success or failure is normally assessed on the basis of how closely the set objectives are met. In most cases, management strategies and plans have been arrived at through analytical tools and models since experimentation with such systems is very expensive and impractical. Extrapolation, however, beyond experience is doubtful and several failures have occurred, most of which can be attributed to one or more of the following:

1. the model does not adequately cover all essential features of the real system;
2. a fragmented, component-view approach is taken where, for example, water pollution, air pollution, and pesticide use are studied in isolation;
3. unsatisfactory interaction between the analyst and the DM;
4. lack of analytical tools for dealing with multi-objective cases even when a consensus as to the ordering of the region's objectives vis a vis environmental quality and economic benefits is possible.

The framework outlined here is an attempt to deal with these four deficiencies.

Very few efforts have been reported in the literature for modeling total economic-environmental systems; a realistic model is often too complex to analyze while an easy to analyze model is unrealistic. Two recent modeling efforts reported seem promising in reconciling realism with complexity, although they have yet to be tested in a real case [1, 2]. Both take a total-system view, allow for a significant level of detail and realism, and are amenable to mathematical optimization; the first is simpler to use and practical while the second is broader in scope but less practical.

The purpose of this paper is to outline an analytical prescriptive framework which is expected to satisfy the need of the DM for an effective, practical, and reasonably objective management tool; specifically, the model [1] will be restructured with a view at improving the interaction between the analyst and the DM and at better dealing with multiple objectives. Through this framework, alternative waste management policies or schemes are to be generated and presented to the DM, along with their evaluation on the basis of:

1. each policy's impact on the economic, environmental, and technological components of the system;
2. established *criteria*, i.e. measures of effectiveness for the alternatives; and
3. the DM's preferences.

Ability to evaluate the impact of a policy on the overall system depends on the realism of, and degree of order in, the model. The choice of criteria, on the other hand, as well as their priority ranking, is the output of a political process reflecting, hopefully, society's preferences. The desirable levels of these criteria are referred to as *objectives* (or *goals* or *targets*) of the DM. The analyst is concerned with developing policies for getting as close to these objectives as is economically, technically, practically, and legally feasible. Usually, not all objectives can be attained within the limits of available resources and a compromise is sought based on the DM's preferences. In the opinion of this author, goals should be initially set before and independently of the attainability examination whose results should be considered only for goal revision; this is necessary for maintaining the right perspective and avoiding sub-optimization.

Frequently employed criteria can be grouped as follows:

1. Environmental Quality
 - air quality in each airshed
 - water quality in each waste receiving body
 - other types of wastes
 - other environmental hazards or nuisances
2. Economic Activities
 - levels of specific activities (e.g. industries)
 - relations among activities levels
3. Spending for Waste Management (total system or separate subsystems).

There exist several approaches to the multi-objective problem [3]. A very widely used approach in environmental management is the development of trade-off relations among conflicting criteria; these relations are the final output of the analyst's work and, on the basis of them, the DM is expected to arrive at a "best" policy guided by his own preferences. Suppose that Figure 1 shows trade-off curves among criteria A, B, and C, with G_i the initially set goal for criterion i . Confronted with curves (i), the DM is forced into some compromise within "triangle" (a, b, c), the exact point depending on his preferred marginal rates of substitution among A, B, and C; from curves (ii), the compromise set would be within triangle (e, d, f) which in general may not overlap with (a, b, c). The DM has still not established a "best" policy. The above process reveals that 1. for a reasonable number of trade-off relations the DM is probably bound to get as confused as when he

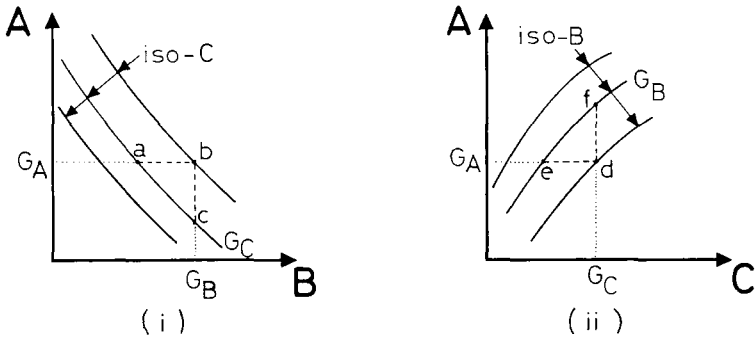

Figure 1. Trade-off curves.

originally called upon the analyst; 2. an essential required input to the process is the DM's desired marginal rates of substitution among the criteria and probably an indirect assignment of priorities among them; and 3. when these rates are not fixed in the DM's mind the process might even get more confusing.

An improvement over this process is a technique called Goal Programming (GP) [4]. In essence, GP provides the analytical means for generating policies corresponding to one or more equally desirable compromises among the goals, on the basis of "objective" marginal rates of substitution and subjective priority rankings, by implicitly examining trade-off relations (without the curves); extending the analysis deeper, GP also provides the means (through curves) for assessing the sensitivity of "best" policies on variations in the priorities among criteria.

A Multi-Objective Model for Waste Management

Network flow models have been used to represent a physical system which is characterized by flows of some quantities. Here this type of model will be used to represent *transformations* of quantities. In a general sense, a quantity is "transformed" when it changes form or location in a way that affects the types and attributes of further transformations. The basic structure of the model is shown in Figure 2. A waste management network connects the waste transformation network with the $|P|$ waste generating activities and the $|R|$ residual-waste receiving media. A node of the waste transformation network corresponds to a specific waste type, an arc to a waste transformation process. The arc leaving a waste source represents the operation of the corresponding economic activity, the flow in the arc being proportional to the operation level; arcs connecting residual-waste nodes with environmental sinks represent waste discharges. Each arc (i, j) has four parameters associated with it: the transformation coefficient t_{ij} which gives the amount of waste

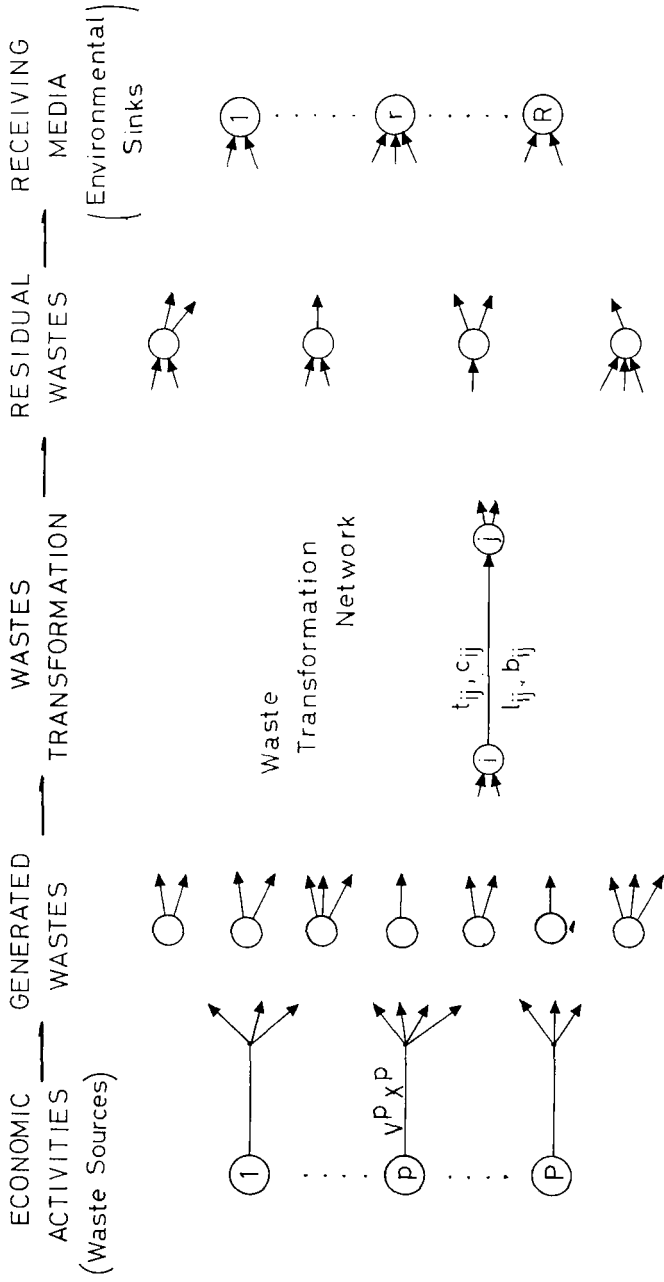

Figure 2. The waste management network.

type j per unit of waste type i entering arc (i, j) ; the cost $c_{ij}(f_{ij})$ of having flow of form j at level f_{ij} in (i, j) ; and the lower and upper bounds— l_{ij} , b_{ij} —on the flow through (i, j) . The flow through an arc is in general a variable quantity whose value is to be computed. These flow values indicate whether and at what level an industry operates, an incineration or a treatment plant is used, or a discharge standard is satisfied.

There are *transformation nets* connecting each source with one or more sinks, “transforming” raw materials or population into discharged wastes. A net starts off at a source as a path along nodes and arcs toward the sinks; at a transformation process which yields jointly two or more waste products (like an industry generating several wastes or incineration yielding ashes and particulates) the original path branches out to several paths one for each waste form. If the flow in the first arc of the k^{th} net from source p is x_k^p and v^p is the value per unit flow from p , the total value of flow from p is $v^p \sum_k x_k^p$; the flow arriving at an end point of the net equals x_k^p times every t_{ij} along the path from p to the particular sink. The flow in arc (i, j) due to net k from source p equals x_k^p times every t_{ij} from p to (i, j) , and the summation over k and p yields the total flow f_{ij} in (i, j) .

A net from p represents a particular waste management scheme for the wastes generated at p . The DM is interested in that combination of nets for which the resulting flows come as close as possible to satisfying his goals. Clearly, there are several processes whose level is restricted by technological, physical, social, or legislated limitations. A *feasible* flow pattern or waste management scheme is one such that:

- a. the total flow through an arc (i, j) is within prescribed limits or equal to a fixed level. E.g. the capacity of an existing treatment plant cannot be exceeded; the amount of CO_2 discharged in an airshed cannot exceed an allowable level; the operation of an industry must reach at least a certain level. Using the notation above, this requirement can in general be expressed as,¹

$$l_{ij} \leq f_{ij} \leq b_{ij} \quad (1)$$

and

- b. special requirements on functions of arc flows be satisfied. Thus, the level of an industry might depend on the level of population or of another industry, and a particular process might not be operational unless another process reaches a certain level. In general, this can be expressed as,

$$f_{ij} + g f_{m,n} \leq h \quad (2)$$

where g and h are unrestricted constants.

¹ “ \leq ” implies “ \leq ” and/or “ $=$ ”

The criteria outlined in the previous section for evaluating feasible patterns correspond to arc flows in Figure 2 as follows: A. Environmental quality: arcs leaving the waste transformation network and entering the sinks (*outflows*, the lower the better); B. Economic activities: arcs leaving the waste sources (*inflows*, the higher the better); and C. Spending: the cost of arc flows (the lower the better). In a singular objective analysis leading to trade-off relations, one could look for the minimum-cost flow pattern for prescribed inflows and controlled outflows, a minimum weighted combination of outflows for controlled inflows and budget, or a maximum inflow-value pattern for controlled budget and outflows.

In the multi-objective GP analysis all objectives are pursued simultaneously in an attempt to reach all goals as closely as possible and according to the DM's preferences; in analytical terms, this is equivalent to minimizing a weighted sum of the deviations from the set goals. Turning to the network model, if U is the set of all arcs in the waste management network and V is the set of arcs whose flow f_{ij} is desired to reach a goal or target T_{ij} , the GP problem is to determine f_{ij} for each (i, j) in U and d_{ij}^-/d_{ij}^+ for each (i, j) in V such that (1) and (2) hold for all (i,j) in U

$$f_{ij} + d_{ij}^- - d_{ij}^+ = T_{ij}, \text{ all } (i, j) \text{ in } V \tag{3}$$

$$\sum_{(i,j) \in U} c_{ij}(f_{ij}) + d_B^- - d_B^+ = B \tag{4}$$

and

$$\sum_{(i,j) \in V} p_{ij} w_{ij} [u_{ij}^- d_{ij}^- + u_{ij}^+ d_{ij}^+] + p_B w_B [u_B^- d_B^- + u_B^+ d_B^+] \tag{5}$$

is minimum,
where,

d_{ij}^-/d_{ij}^+ is the amount by which f_{ij} is under/over T_{ij} ;

B is the budget the DM plans for, consisting of a "fixed" portion plus a variable portion which is a function of some economic activities levels;

d_B^-/d_B^+ is the amount by which actual spending is under/over the budget;

u_{ij}^-/u_{ij}^+ is a constant indicating the DM's preference for being under/over T_{ij} ;

w_{ij} is a marginal rate of substitution of a chosen base criterion for the criterion corresponding to flow f_{ij} ; and p_{ij} is a constant reflecting the priority of T_{ij} in relation to the other goals.

Constraints (1) and (2) are called *feasibility* constraints while (3) and (4) are called *criteria* constraints; a criterion constraint similar to (2) with h the desirable goal is also possible but left out for simplicity. Except for the non-linear cost functions which are dealt with by a branch-and-bound approach, problem (1) through (5) is a linear programming one with the criteria

constraints having both “slack” (d_{ij}^-) and “surplus” (d_{ij}^+) variables while the objective function to be minimized is a weighted sum of these deviations from the targets. The size of this problem depends on the scope of the analysis and the degree of detail desired; for a real case, there could be up to 1000 arcs and 500 constraints. For analogous models with a singular objective a solution procedure, especially efficient for large networks, has already been reported [5]. Unlike most GP cases, there is no increase in computational effort when this procedure is adopted to the GP model.

The flow pattern(s) solving the above GP problem, for given objective function coefficients in (5), constitute the best alternative(s) for the DM in the sense that there is no other pattern having a better score for at least one criterion and the same score for all the other; such patterns are called *efficient* or *nondominated* [6]. The set of efficient patterns clearly depends on the values of the coefficients in (5); the assignment of these values is often the most critical, complex, and controversial aspect of GP. The initial assignment should be regarded as a start only and be revised through a continuous consultation with the DM, as outlined in detail in the next section. It should be noted that the trade-off-curve analysis involves the same controversies with regard to this assignment.

Fortunately, however, the nature of the GP model considered here greatly simplifies this problem. Thus, for the environmental management case most of the criteria constraints are *one-sided*, i.e. deviation from the target is desirable from one side and undesirable from the other; for example, since under-achievement for spending or for an environmental standard criterion is welcome, d_B^- and d_{ij}^- need not be minimized, and $u_B^- = u_{ij}^- = 0$; conversely, for an industrial level criterion where over-achievement is welcome, $u_{ij}^+ = 0$. In fact, unless this assignment is made for one-sided criteria, the solution will be unrealistic. All nonzero u_{ij} 's are set equal to 1 in order to preserve the relative significance of each p_{ij} and w_{ij} . For the w_{ij} 's, it is convenient to choose spending as the base criterion ($w_B = 1$), and set w_{ij} equal to the amount spent or saved when f_{ij} deviates by one unit from a specified level; when a direct trade-off between f_{ij} and spending is meaningless, w_{ij} is determined through a third criterion whose trade-off between both f_{ij} and spending is defined. These w_{ij} 's can be easily computed by the model, even though rough estimates will normally suffice. Should the DM not be satisfied with the efficient solutions generated through the above “objective” assignments of u_{ij} 's and w_{ij} 's and with all p_{ij} remaining at unity, priorities are assigned to the goals.

Before an example is presented, some of the capabilities of the model which are not apparent in the exposition here should be mentioned:

1. treatment of nonlinear cost functions and variable efficiencies in transformation processes;

2. budget as nonlinear function of population level and/or industrial level;
3. relationship of labour force with levels of various industries;
4. recycling of waste products;
5. treatment of effluent standards and charges, and of damage functions;
6. determination of whether, when, and at what capacity level a facility would be needed under a growing waste-generation rate.
7. determination of whether and at what level the capacity of a process should be improved;
8. separate semi-independent waste management subsystems, each with its own budget, indirectly controlled by a central DM through charges, incentives, and regulations suggested by the model;
9. identification of waste management schemes for each waste source along with assessments of their effect on all aspects of environmental quality, on economic activities, and spending;
10. flow in some processes conditional on flows in others.

Finally, the max-inflow, min-cost, and min-outflow problems can be formulated as special cases of the above formulation by appropriately assigning values to the objective function weights. For example, the min-cost solution for a desirable inflow can be obtained by assigning a large value to p_B , letting $B = 0$, and fixing the inflow at the desirable level; the optimal value of d_B^+ is the minimum cost level.

An Example

A simple environmental management case is presented in Figure 3, while Figure 4 shows the detailed network model. The levels of all processes are expressed in a uniform time rate—1 day. The figures for costs and waste transformations are derived from realistic data, reported extensively in the literature, by simple manipulations [1]. In this example, arc (1, 3) corresponds to an industrial activity generating a useful product (in units of 10^3 tons/day) jointly with solid and liquid wastes; the level of the residential and commercial sector is in terms of 1000 people, along arc (2, 4), generating solid wastes, garbage, and liquid wastes. A triangular node in Figure 4 indicates that the process ending at the node generates more than one waste form jointly. Liquid wastes (nodes 7, 9, 15, and 24) are measured in tons of biochemical oxygen demand (BOD). All solid wastes converge into node 11; they can either be incinerated along (11, 13) yielding ashes (tons) along (13, 18) and particulates (tons) along (13, 19), or transported to a landfill site. Arc (20, 21) is the process of building a transfer station and transporting wastes from there to the landfill; node 21 corresponds to solid wastes destined for either of the landfill sites and includes the sludge of node 17 which is transported along (17, 21). Arc (18, 23) allows the incineration residue to bypass the open

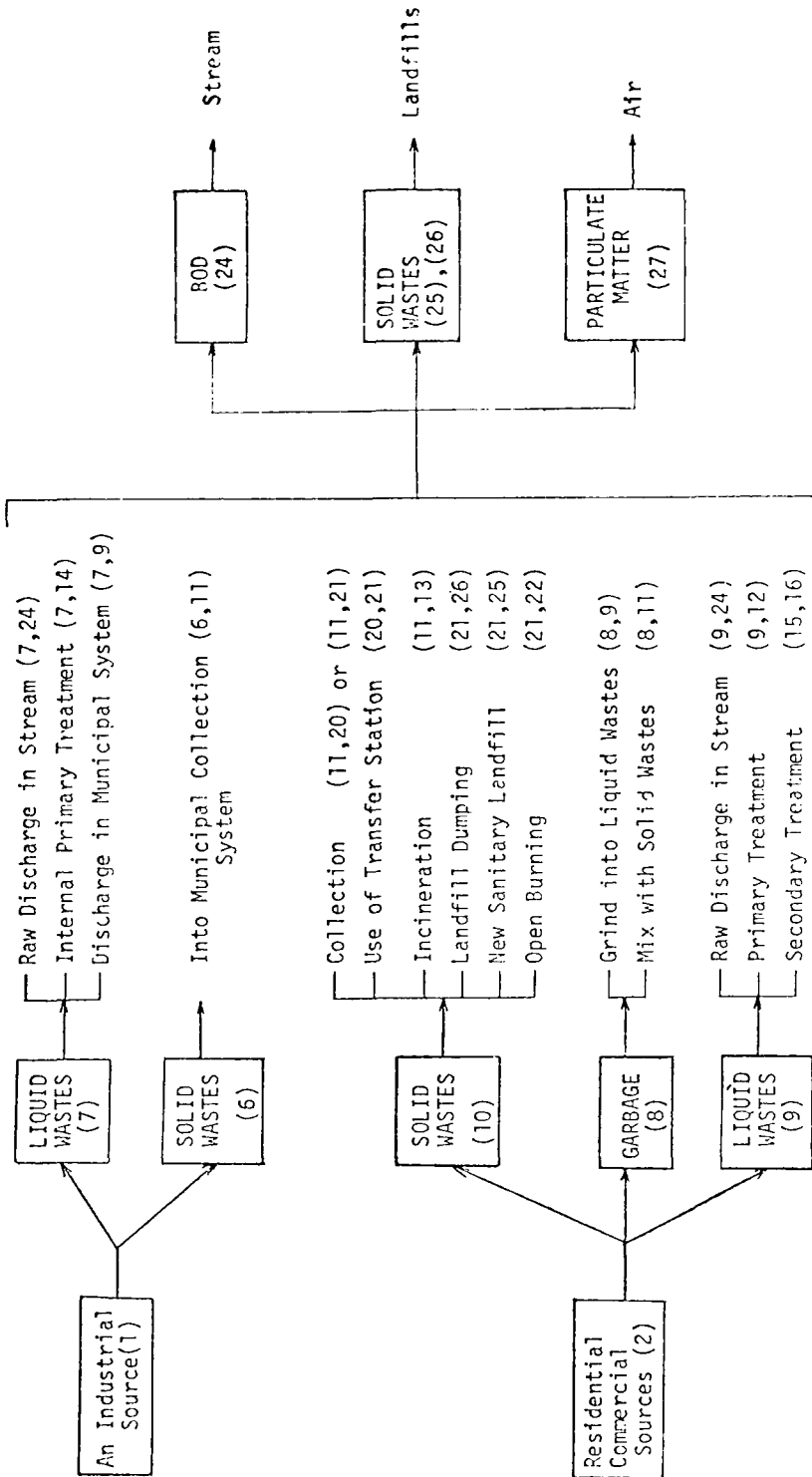

Note: (k) and (i,j) imply node k and arc (i,j) in Figure 4

Figure 3. A simple environmental management case.

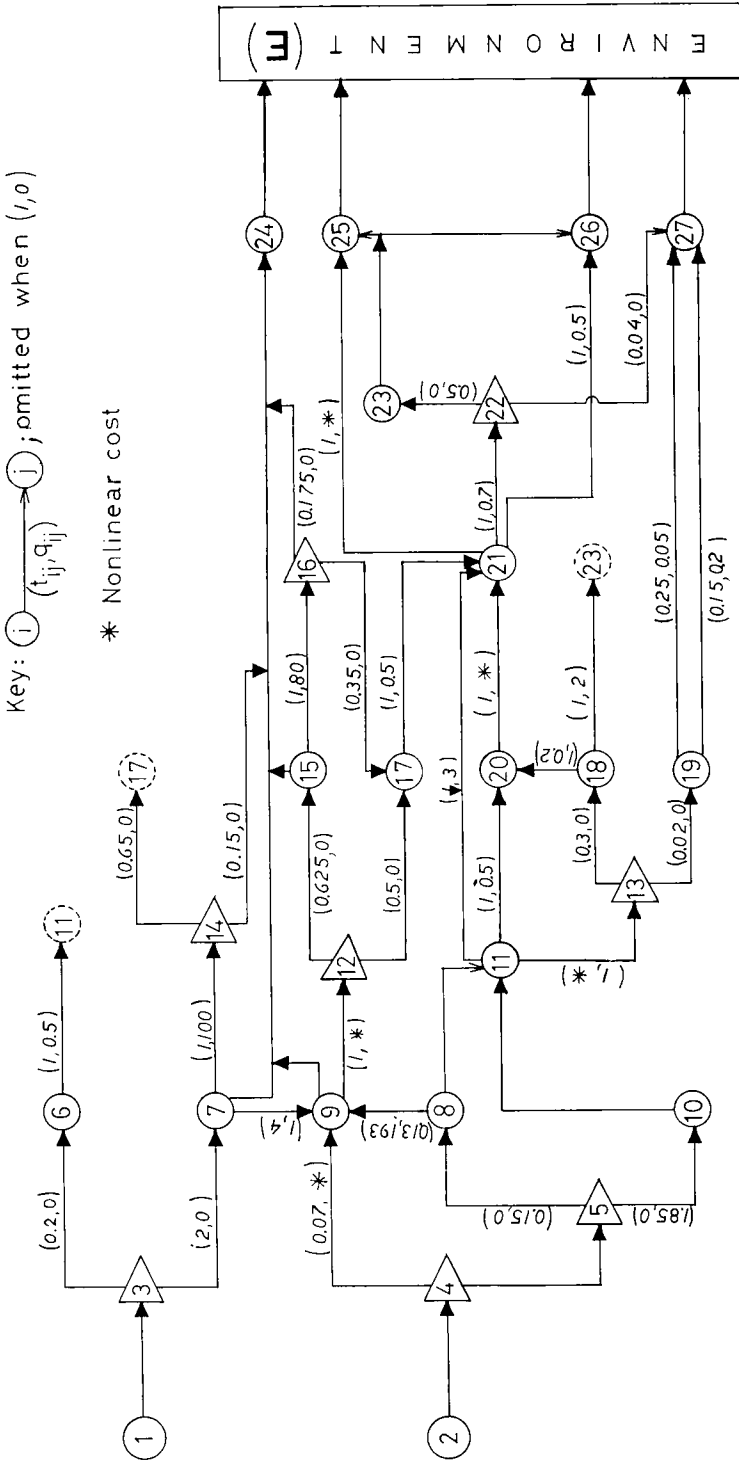

Figure 4. The example network model.

burning process (21, 22); arcs (19, 27) correspond to two air pollution schemes. Cost functions are assumed linear with $c_{ij}(f_{ij}) = q_{ij}f_{ij}$ except for the following processes corresponding to building or expansion of facilities: (20, 21), transfer station; (9, 12), primary treatment plant; (21, 25), sanitary landfill; (11, 13), incinerator; and (4, 9), sewage collection system.

The authority-in-charge wishes to develop a feasible and efficient flow pattern, utilizing only the shown processes, for discharging the generated wastes into node E. A typical net from node I is (in node sequence): 1, 3, 6, 11, 21, 26, E branching out at 3 into 3, 7, 24, E; for a unit level in (1, 3), the flow in (26, E) is $(1)(0.2)(1)(1)(1) = 0.2$ tons while in (24, E) it is $(1)(2)(1)(1) = 2.0$ tons.

The feasibility constraints are:

1. the incineration level does not exceed 30 tons/day; $b_{11,13} = 30$.
2. the existing landfill capacity does not exceed 200 tons/day; $b_{26,E} = 200$.
3. should the new landfill be built, its capacity will not exceed 100 tons/day; $b_{25,E} = 100$.
4. the discharge of industrial liquid wastes into the municipal sewerage system does not exceed 8 tons BOD/day; $b_{7,9} = 8$.
5. the amount of particulates generated by open burning of solid wastes does not exceed 0.32 tons/day; $b_{22,27} = 0.32$.
6. no solid wastes are discharged into the new landfill unless that is built; $f_{23,25} \leq M f_{21,25}$, where M is a large number.
7. for each of the 8 triangular nodes, the flows in the arcs leaving the node are related as jointly generated.

The criteria constraints are:

8. air quality: amount of particulates discharged, $f_{27,E}$, should not exceed a target $T_{27,E} = 0.50$ tons/day.
9. water quality: amount of BOD discharged, $f_{24,E}$, should not exceed a target $T_{24,E} = 3.0$ tons/day.
10. the population level $f_{2,4}$ should reach a target $T_{2,4} = 100$ thousand.
11. to secure a healthy relation between population $f_{2,4}$ and industrial activity level $f_{1,3}$, it is desirable that $f_{1,3}$ reach a target equal to $\alpha f_{2,4}$, where α is a constant set at 0.10 in this example.
12. spending: total daily cost should not exceed a target B equal to \$1000 plus \$0.02 per person in arc (2, 4).

What follows is an overall solution procedure suggested for the analyst, including value assignment for the objective function coefficients; reference to the example considered here is made for clarity:

Step 1: u_{ij}^+/u_{ij}^- is set equal to 0 if over/under-achievement of T_{ij} is desirable; otherwise, set equal to 1. Here, $u_{24,E}^- = u_{27,E}^- = u_B^- = 0$.

- Step 2: a. Choose a base criterion and set its $w_{ij} = 1$. Here $w_B = 1$.
- b. For any other criterion, w_{ij} is initially set equal to an estimate of the marginal rate of substitution of the base criterion for f_{ij} when all criteria are close to their goals. Here, $\Delta B/\Delta f_{2,4}$ varies around 15 depending on the proximity to the goals and on the remaining capacity of the nets; thus, $w_{2,4} = 15$; similarly, $w_{24,E} = 2000$ and $w_{27,E} = 3000$. It should be noted that ΔB should contain the effects on spending from all flow changes resulting from a marginal change in a criterion level; only a rough estimate is however necessary at this stage. For criterion constraint 11, an estimate of $\Delta B/\Delta f_{1,3}$ is 200 while $\Delta B/\Delta(\alpha f_{2,4})$, for $\alpha = 0.10$, is 150; a coefficient of 175 is used.
- Step 3: With coefficients as assigned, and all $p_{ij} = 1$, obtain the efficient flow pattern(s). If the DM is satisfied, stop. Otherwise, go to next step.
- Step 4: Adjust each w_{ij} to equal the change in the minimum cost solution of the model when all criteria but the base one are fixed at their current levels and f_{ij} deviates by one unit. (The sensitivity analysis features of linear programming can greatly simplify these w_{ij} adjustment processes.) Re-solve the model. If the DM is not satisfied, re-adjust w_{ij} 's as above and re-solve.
- Step 5: As the solution will become insensitive to w_{ij} changes after the second or third adjustment, if the DM is still not satisfied, either
- suggest to the DM the possibility of goal revision, returning in turn to step 1, or
 - assign his p_{ij} 's to the goals and re-solve.
- Step 6: An examination of the sensitivity of the solution to p_{ij} and T_{ij} values may be helpful to the DM.

Extensive computational experience has been obtained with the McGill IBM 360/75 computer. For the coefficients assigned in step 2, some of the optimal flows in the example network are:

$$\begin{array}{llll}
 f_{1,3} = 6.1 & f_{2,4} = 61 & f_{9,12} = 4.3 & f_{24,E} = 3 \\
 f_{7,9} = 0 & f_{11,13} = 0 & f_{15,16} = 2.7 & f_{25,E} = 0 \\
 f_{7,14} = 11.4 & f_{11,21} = 0 & f_{21,22} = 0 & f_{26,E} = 133.2 \\
 f_{7,24} = 0.8 & f_{20,21} = 122.6 & f_{22,27} = 0 & f_{27,E} = 0
 \end{array}$$

The only unsatisfied goal is $T_{2,4}$ and adjustment of $w_{2,4}$ offers no improvement; $f_{2,4}$ increases appreciably only when $p_{2,4}$ exceeds 5; $T_{2,4}$ is met with $p_{2,4} = 15$ but $T_{24,E}$ and B are well exceeded while $f_{1,3}$ is less than 0.10 $f_{2,4}$. With regard to the dynamic characteristics of the solution when the model is used for planning under population growth, test runs have shown that, due to economics of scale, the transfer station, the incinerator, and the

sanitary landfill become economical at population levels 60,100, and 115 thousand, respectively.

In case a new criterion goal needs to be specified (e.g. a new environmental standard or the level of an activity about to enter the system), a two-sided criterion constraint is inserted into the model with only a rough estimate for the target; the deviation from it would suggest a proper target which would also reflect the DM's preferences and the system's capabilities.

When there is a penalty (or effluent charge) of $\$ \mu_{ij}$ per unit flow over a target T_{ij} , a term $\mu_{ij}d_{ij}^+$ is added to the left-hand side of (4) (subtracted if the DM sets and receives the penalty). Test runs have shown the BOD level in the discharge process (24, E) to be a decreasing function of $\mu_{24,E}$, as expected; similar runs have also shown that the effect of the μ_{ij} level on the solution is comparable to that of the product $w_{ij}p_{ij}$. Thus, for a μ_{ij} (corresponding to a target T_{ij}) and a w_{ij} , an estimate for p_{ij} is μ_{ij}/w_{ij} .

Conclusion

The analytical framework outlined here is suggested as a total-system management tool for an economic-environmental system at the regional level. The network model along with the efficient solution algorithm for large networks allow for a detailed and sufficiently realistic exposition of alternatives in a manner understandable to local groups whose participation in setting up criteria and goals is often mandatory. The continuous participation of the DM in the process of developing and evaluating alternatives and his non-elaborate interaction with the analyst render the results more acceptable to him. For given criteria, this framework balances generation of benefits with resulting environmental quality, as well as the operating levels of waste-specific treatment and disposal subsystems. For example, a change in the BOD discharge limit (process (24, E), Figure 4) affects the amount of generated sludge which affects the level and type of solid waste disposal processes, while it may also affect the industry or population level. In indicating exactly which processes are affected by a specific disturbance or modification in the system, and to what extent, the model can serve as a basic framework for balancing conflicting tendencies within the total system when several partially independent and loosely bound DM's are operating.

REFERENCES

1. D. Panagiotakopoulos, "An Optimization Model for Balancing Economic-Environmental Systems," *Canadian Journal of Civil Engineering*, Volume 2, Number 1, 1975.
2. C. S. Russel and W. O. Spofford, "A Quantitative Framework for Residuals Management Decisions," in A. V. Kneese and B. T. Bower, (eds.), *Environ-*

mental Quality Analysis, Resources for the Future, Inc., The Johns Hopkins Press, 1972.

3. B. Roy, "Problems and Methods with Multiple Objectives Functions," *Mathematical Programming*, Volume 1 (1971), 239-266.
4. A. Charnes and W. W. Cooper, *Management Models and Industrial Applications of Linear Programming*, John Wiley and Sons, New York, 1961.
5. D. Panagiotakopoulos, "Multi-Commodity Multi-Transformed Network Flows with an Application to Residuals Management," Report No. UES 75-10, Civil Engineering, McGill University, January 1975, to appear in *Management Science*.
6. M. Zeleny, *Linear Multiobjective Programming*, Lecture Notes in Economics and Mathematical Systems, 95, Springer-Verlag, New York, 1974.