

HETEROCYCLES, Vol. 64, 2004, pp. 317 - 331

Received, 27th July, 2004, Accepted, 4th October, 2004, Published online, 5th October, 2004

ALTERNATIVE ACCESS TO LACTOSAMINE-DERIVED OXAZOLINE VIA 2-ULOSE OXIME AS A KEY INTERMEDIATE

Eisuke Kaji,* Yumiko Osa, Naomi Shinohara, Chiho Yanagi, Masae Sekine, and
Takashi Nishino

School of Pharmaceutical Sciences, Kitasato University, Shirokane 5-9-1,
Minato-ku, Tokyo 108-8641, Japan; kajie@pharm.kitasato-u.ac.jp

Abstract – Lactosamine-derived oxazoline was synthesized via 2-ulose oxime as a key intermediate, in which substituent effects of the acyloxyimino group were investigated. On reduction of the oxime to amino group, *p*-chlorobenzoyloxime provided a good *gluco* : *manno* selectivity of 13 : 1. *N*-Acetyllactosaminyl chloride derived therefrom was readily converted into the oxazoline by AgOTf-promoted cyclization with an 84% yield.

N-Acetyllactosamine-derived oxazoline (LacNAc-oxazoline) has been amply utilized as a proper lactosaminyl donor for chemical assembly of immunologically relevant, lactosamine-containing oligosaccharides.¹ Since LacNAc-oxazoline is considered to be a cyclic equivalent of LacNAc, its donor capacity might be preferable with respect to the stability and facility for preparation, storage, and handling. Moreover, LacNAc-oxazoline can directly regenerate LacNAc itself after glycosylation of an appropriate glycosyl acceptor, without further deprotection process of the amino function followed by *N*-acetylation, required for such lactosaminyl donors possessing *N*-Phthalimido-² and *N*-Troc-³ groups. Previously, the main approach to LacNAc-oxazoline was based on Lewis acid-promoted oxazoline formation from either per-*N,O*-acetyllactosamine⁴ or its α -chloride analog,⁵ both of which were prepared from LacNAc, a common precursor. However, the present prohibitively high price⁶ for LacNAc strongly impedes its use for subsequent operations, and chemical acquisition of *N*-acetyllactosamine is still cumbersome. Consequently, lactosamine has been synthesized mainly by an azidosugar method,⁷ requiring multi-step sequences with careful manipulations.

Apparently, a straightforward, practical synthesis of LacNAc-oxazoline has been requested for the chemical assembly of LacNAc-containing oligosaccharides of biological significance. Herein we

disclose our novel method for synthesizing LacNAc-oxazoline by way of lactos-2-ulose oxime as a key intermediate, providing highly stereoselective manner.

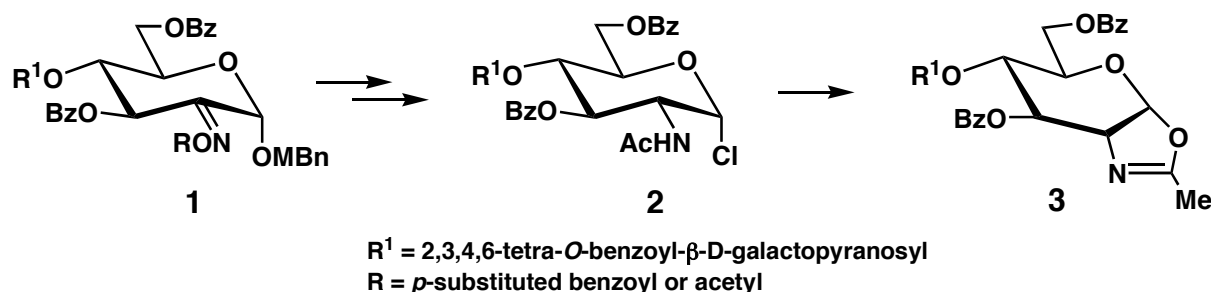

Scheme 1. Synthetic Access to Lactosamine-derived Oxazoline

Our approach to LacNAc-oxazoline synthesis is based on our previous works concerning the synthesis of lactosamine derivatives^{8,9} and lactosaminyl donors.³ In the present protocol (cf. Scheme 1) LacNAc-oxazoline (**3**) might be synthesized from *N*-acetyl lactosaminyl chloride (**2**), which should be prepared from 2-acyloxyiminoglycoside (**1**) by means of stereoselective reduction of the 2-oximino function to afford *gluco*-type amino sugar, a crucial step. In this context, we evaluated the substituent effects on the reduction of the acyloxyimino function so that high stereoselectivity of the *gluco* : *manno* configuration of the resulting amino sugar could be attained.

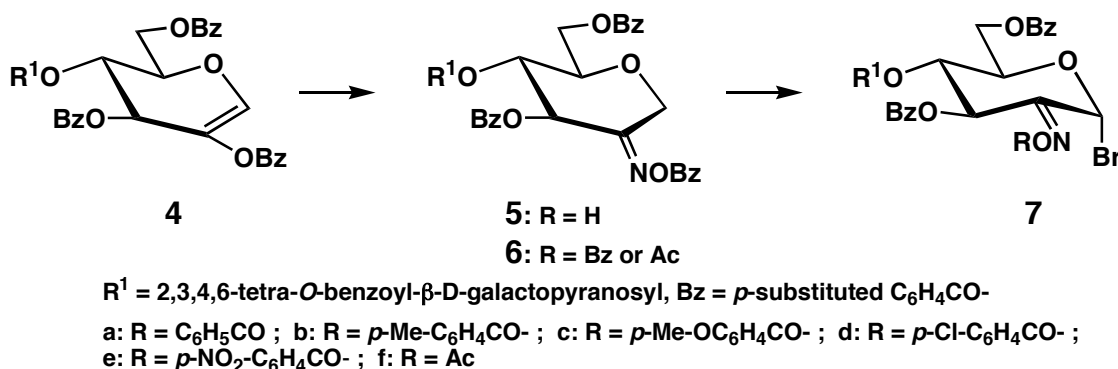

Scheme 2. Preparation of Galactosyl- $\beta(1\rightarrow4)$ -2-oximino-glycosyl Bromides

At first, we synthesized 2-acyloxyiminoglycosyl bromides (**7a-f**) possessing various substituents at the *para* position of the benzoyl group, as shown in Scheme 2. Compound (**4**) was prepared with a 76% overall yield 3 steps from lactose, and was subjected to oximation with hydroxylamine, affording 2-ulose oxime (**5**) in 89% yield, which was subsequently acylated with various *p*-substituted benzoyl chlorides and acetic anhydride to provide **6a-e** and **6f**, respectively in 87-95% yields. The configuration of the pyranoid ring of **6** was estimated to have twist-boat form ($J_{3,4} = ca. 4.5$ Hz), possessing *E*-oriented

acyloxime group, since C-1 *quasi*-equatorial proton was de-shielded to δ 5.1 ppm, affected by the nearby acyloxyimino group. Subsequently, the oximes (**6**) were converted into lactos-2-ulosyl bromides (**7**) by photo-bromination¹⁰ with *N*-bromosuccinimide (NBS) in tetrachloromethane in 85-95% yields.

As previous studies¹¹ revealed that α -glycosidulose oximes are selectively converted into α -glucosaminides, whilst β -glycosidulose oximes are led to β -mannosaminides, α -selective glycosidation of **7** yielding **1** is essential for subsequent reduction of **1** to α -lactosaminide (**9**) (cf. Scheme 3). We examined glycosidation of **7** using *p*-methoxybenzyl alcohol as an easily removable aglycon group. As shown in Table 1, an organic soluble promoter such as *s*-collidine in dioxane (Runs 1-6) selectively generates α -glycosides (**1**) in preference to β -glycosides (**8**), whilst an insoluble silver salt promoter resulted in the β -glycoside (**8**), predominantly (Run 7). It is reasonable to assume that the high α -selectivity yielding **1** may be attributed to the fact that the solvent dioxane promotes double inversion at the anomeric center *via* intermediary β -alkoxonium ion formation. Over the experiments of Runs 2-6, no remarkable effect of the oxyimino substituents was observed.

Table 1. Stereoselective Synthesis of *p*-Methoxybenzyl Glycosides (**1** and **8**)

Run	R	Promotor ^{a)}	Yields (%) (1 + 8)	[α] _D ^{b)}	1 : 8 ^{c)}	NMR		
						H-1	J _{3,4}	C-1
1	Bz	A	80	+ 107	10 : 1	6.04	9.0	88.6
2	<i>p</i> -Me-C ₆ H ₄ CO-	A	84	+ 89	10 : 1	6.03	9.0	88.7
3	<i>p</i> -MeO-C ₆ H ₄ CO-	A	80	+ 98	10 : 1	6.01	9.0	88.5
4	<i>p</i> -Cl-C ₆ H ₄ CO-	A	83	+ 98	10 : 1	5.98	9.0	88.2
5	<i>p</i> -NO ₂ -C ₆ H ₄ CO-	A	82	+ 86	10 : 1	5.96	9.0	87.9
6	Ac	A	83	+ 87	10 : 1	5.94	9.0	89.6
7	Bz	B	78	+ 83	1 : 10	5.93	4.0	91.3

a) A : *s*-collidine / I₂ / MS-3A in dioxane ; B : Ag₂CO₃ / I₂ / MS-3A in CH₂Cl₂

b) Measured in CHCl₃ (c = 0.5). c) Estimated by ¹H-NMR spectral integration.

In the oxyiminoglycosides (**1**) and (**8**), lacking the C-2 proton, J_{3,4} values were quite useful for assignment of the anomeric configuration. The sizable J_{3,4} couplings of 9.0 Hz, clearly revealed *CI* conformation of the pyranoid ring, whilst the β -anomer (**8**) exhibited a smaller coupling constant of 4.0 Hz, indicating a conformation substantially distorted towards a twist-boat form. As previously described, the steric repulsion between the 2-acyloxyimino group and β -oriented aglycons might lead to conformational change so as to induce a less steric interaction.

Next, α -lact-2-ulosides (**1**) were converted into α -lactosaminide (**9**) by stereoselective hydroboration. For these experiments, the substrates were used as anomeric mixtures of α -anomer (**1**) : β -anomer (**8**) = 10:1, which were obtained by the glycosidation of **7** (cf. Table 1).

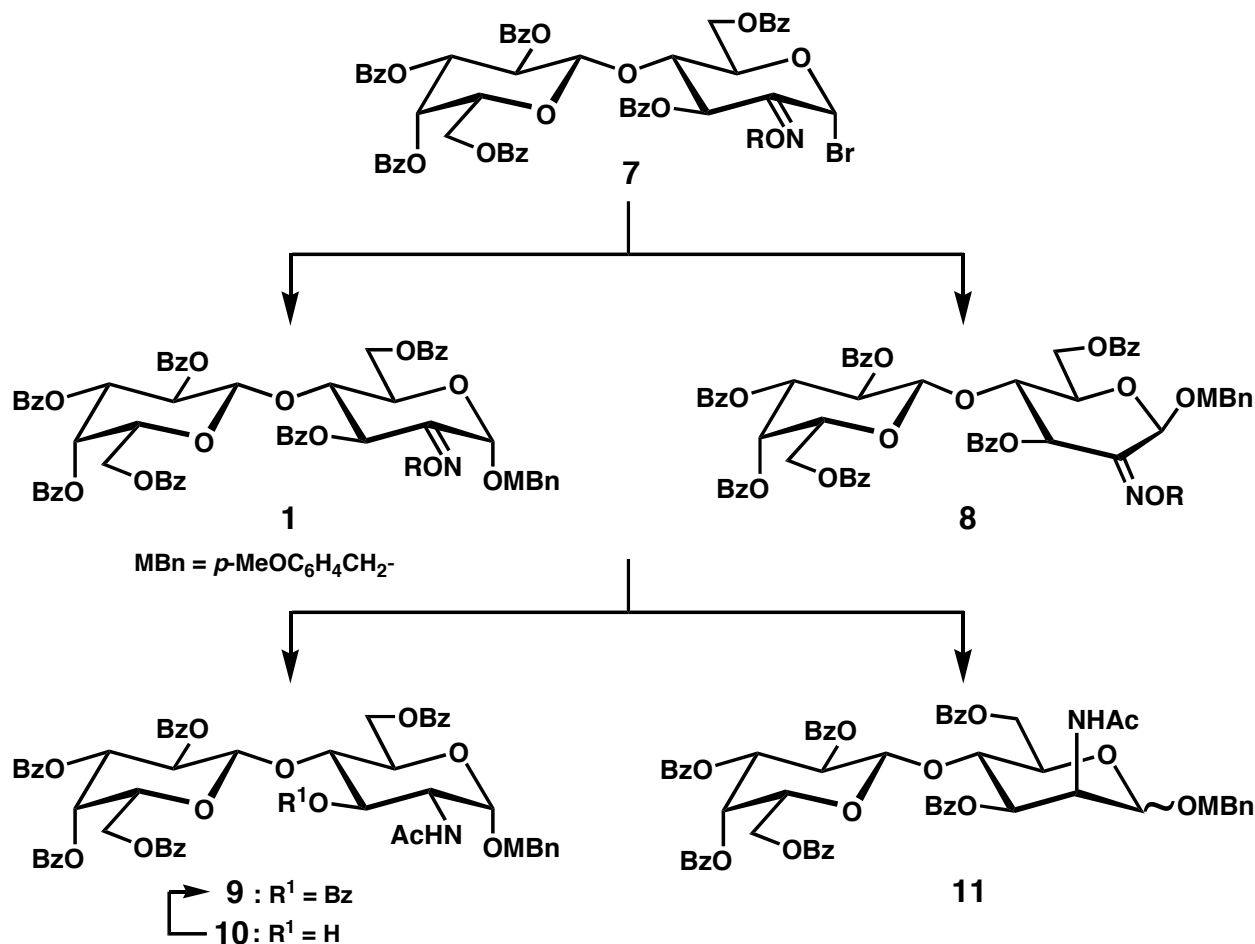

Scheme 3. Synthesis of *N*-Acetyllactosamine Derivatives by Reduction of 2-Oximino glycosides

Table 2 summarizes the reaction conditions and results of the stereoselectivity. As shown in the experiments for Runs 1-4, 12 to 14 molar equivalents of BH_3 to the educt **1** provided high yield conversion to the products (**9** and **10**). It is noteworthy that regioselectively deprotected *N*-acetyllactosamine with a free 3-OH group (compound (**10**)) was obtained along with the fully protected compound (**9**). No compound with a free 3-OH group derived from the mannosaminide (**11**) was obtained. The partially protected **10** would be utilized as a versatile building block for construction of 3-fucosylated *N*-acetyllactosamine, the so called Lewis X antigen,¹² relevant to a cell adhesion molecule. The very minor isolated byproducts have been determined to be an anomeric mixture of galactosyl- β (1 \rightarrow 4)-mannosaminide (**11**), of which the α - and β -anomers might be formed from the starting substrates (**8** and **1**), respectively. The *para* substituents of 2-benzoyloxyimino group of **1** affected the stereoselectivity such that *p*-chloro derivative (**1d**) provided the best *gluco* : *manno* ratio of 13 : 1 (Run 7).

However, we have no reliable evidence of relationships between stereoselectivity and substituent effects (cf. Table 2, Runs 5-8). Reductions of acyloxyimino group with reagents other than diborane were also tested, for example, $\text{NaBH}_4\text{-NiCl}_2$,¹³ $\text{NaBH}_4\text{-MoO}_3$,¹³ and $\text{LiBH}_4\text{-Me}_3\text{SiCl}$ ¹⁴ almost recovered the substrate **1** (70-80%) along with a small amount of the lactosamine (**9**) (4-7%).

The configuration of the amino sugar moieties of the disaccharides (**9**) and (**10**) could be readily assigned as *gluco* from their $J_{2,3}$ values of around 10 Hz, whilst that of **11** was deduced to be *manno* from its $J_{2,3}$ value of around 4 Hz. The 3-OH free analog (**10**) was deduced from the H-3 chemical shift shielded to a sizably higher magnetic field (δ 3.8-4.0) compared with that (δ = 5.65) of 3-*O*-benzoylated analog (**9**).

Finally, methoxybenzyl lactosaminide (**9**) was readily converted into the respective oxazoline (**3**) via α -chloride (**2**) in good yield. Thus, exposing the lactosaminide (**9**) to cerium(IV) ammonium nitrate in acetonitrile-water afforded 1-OH free **12** in 80% yield. Subsequent chlorination of **12** with thionyl chloride in DMF provided lactosaminyl α -chloride (**2**) in 72% yield. The α -chloride (**2**) was unequivocally characterized, involving the anomeric configuration by optical rotation, MS, and NMR spectra (cf. EXPERIMENTAL).

The conversion of α -chloride (**2**) into oxazoline (**3**) was readily accomplished in 84% yield with silver triflate (AgOTf) / 1,1,3,3-tetramethylurea (TMU) in dichloromethane. In this case, oxazoline formation

Table 2. Synthesis of Fully and Partially Deprotected *N*-Acetyllactosamine

Run	R	BH_3 / 1 (mol. eq.)	Yields (%)				<i>gluco</i> : <i>manno</i>
			9	10	11	9 + 10	
1	Bz	10	36.1	25.3	6.4	61.4	10 : 1
2	Bz	12	57.1	28.5	8.5	85.6	10 : 1
3	Bz	14	45.9	40.9	9.3	86.8	9 : 1
4	Bz	20	43.1	33.5	11.7	76.6	7 : 1
5	<i>p</i> -Me-C ₆ H ₄ CO-	12	44.6	25.7	a)	70.3	a)
6	<i>p</i> -MeO-C ₆ H ₄ CO-	12	35.2	30.3	12.2	65.5	5 : 1
7	<i>p</i> -Cl-C ₆ H ₄ CO-	14	46.0	25.6	5.6	71.6	13 : 1
8	<i>p</i> -NO ₂ -C ₆ H ₄ CO-	12	26.2	18.1	a)	44.3	a)
9	Ac	12	16.5	20.7	2.9	37.2	13 : 1

a) The yield of **11** was not clearly estimated because of isolation difficulties.

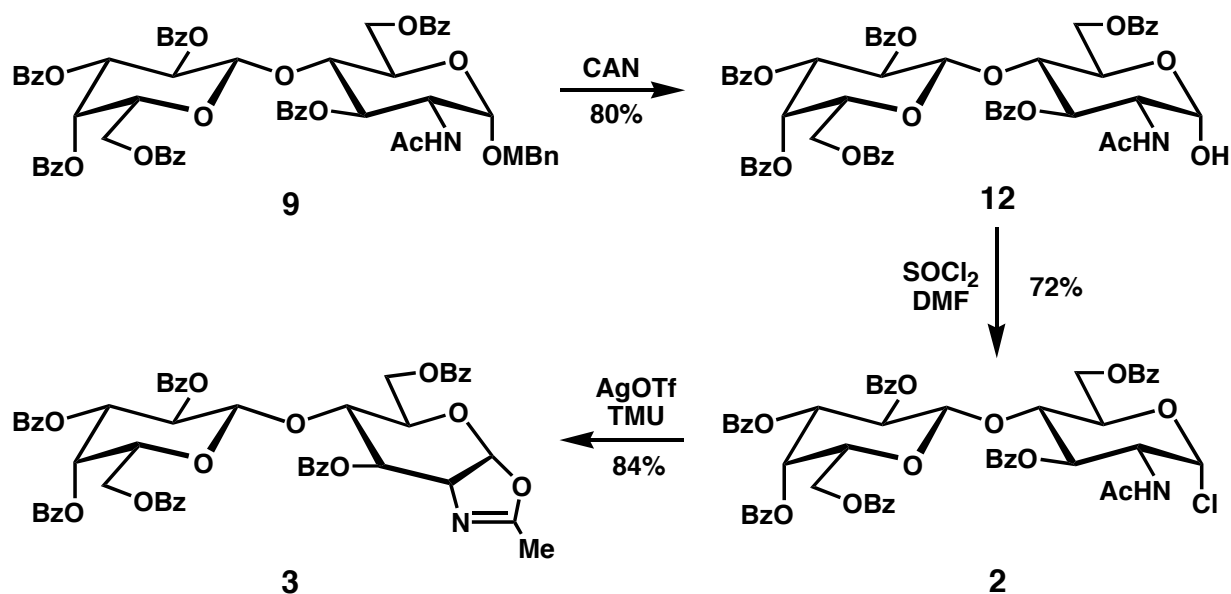

Scheme 4. Synthesis of *N*-Acetylglucosamine-derived Oxazoline

might be rationalized by an analogous mechanism proposed for halogenide ion-catalyzed oxazoline formation from *N*-acetylglucosaminyl α -chlorides,¹⁵ i.e., S_N2 like β -attack of triflate ion to the anomeric center generates β -triflate which would be readily replaced with adjacent acetyl carbonyl oxygen from the α -side to form an oxazoline ring.

In summary, a novel, preparatively useful access to LacNAc-oxazoline has been developed by way of a key intermediate, lactos-2-ulose oxime. This methodology is noteworthy with respect to high stereoselectivity in the reduction of acyloxime to an amino group with a *gluco* : *manno* ratio of 13 : 1. In addition to the fully protected oxazoline, partially protected 3-OH free analog was also attained, which could be utilized for the short step assembly of 3-functionalized lactosamines of biological importance.

EXPERIMENTAL

Melting points were determined on a Yamato MP-1 apparatus and are uncorrected. Spectral data were recorded on the following instruments; JASCO P-1080 ([α]_D), JMS-AX 505 H (MS), and Varian XL-400 and VXR-300 (NMR in chloroform-*d* solution). Column chromatography was carried out on silica gel (Kanto Kagaku Co. up to 100 mesh) column. TLC was achieved on silica gel 60 F254 (Merck Art. 5735). The spots were detected by UV light (254 nm) or charring with 10% aqueous sulfuric acid. Compound (1a,⁸ 6a,⁹ 7a,⁹ and 8a⁸) were obtained by our method described in the literature.

3,6-Di-*O*-benzoyl-4-*O*-(2,3,4,6-tetra-*O*-benzoyl- β -D-galactopyranosyl)-1,5-anhydro-D-fructose (*p*-Methylbenzoyl)oxime (6b) - A typical procedure for acyloxime (6) : A solution of oxime (5)⁹ (2.89 g, 3.00 mmol) and *p*-methylbenzoyl chloride (941 mg, 6.00 mmol) in pyridine (30 mL) was stirred at rt for 20 h. The resulting mixture was diluted with dichloromethane (200 mL) and poured into ice-water (200

mL). Successive washing of the organic phase with each 200 mL of water, 1 M HCl, water, saturated aqueous NaHCO₃, and water was followed by drying (Na₂SO₄) and evaporation to dryness to yield a residue, which was eluted from a silica gel column with toluene-ethyl acetate (4 : 1). The major fraction was concentrated and the residue crystallized from ethyl acetate-ether-pentane to give 2.99 g (92.4%) of **6b** as a colorless powder: mp 103-108°C; $[\alpha]_D^{24} +50.1^\circ$ (c = 1.0, CHCl₃); MS (FAB) *m/z*: 1081 [M-1]⁺, 1104 [M+Na-1]⁺; IR (KBr) ν_{\max} cm⁻¹: 1730 (C=O); ¹H-NMR (300 MHz, CDCl₃) δ : 2.43 (3H, s, CH₃), 3.73 (1H, td, H-5), 4.26 (1H, dd, H-6a), 4.31 (1H, dd, H-6'a), 4.40 (1H, m, H-6b), 4.42 (1H, dd, H-4), 4.43 (1H, m, H-5'), 4.44 (1H, dd, H-6'b), 4.53 (1H, d, H-1a). 5.14 (1H, d, H-1'), 5.15 (1H, d, H-1e), 5.59 (1H, dd, H-3'), 5.80 (1H, dd, H-2'), 5.95 (1H, dd, H-4'), 6.32 (1H, d, H-3); $J_{1a,1e} = 16.5$, $J_{3,4} = 4.0$, $J_{4,5} = 8.5$, $J_{5,6a} = 5.0$, $J_{5,6b} = 2.5$, $J_{6a,6b} = 12.0$, $J_{1',2'} = 8.0$, $J_{2',3'} = 10.0$, $J_{3',4'} = 3.5$, $J_{4',5'} = 1.0$, $J_{5',6a} = 6.0$, $J_{5',6b} = 3.0$, $J_{6a,6b} = 8.0$ Hz; ¹³C-NMR (75 MHz, CDCl₃) δ : 21.73 (CH₃), 61.64 (C-6'), 63.21 (C-6), 64.17 (C-1), 67.87 (C-2'), 71.48 (C-3), 71.61 (C-3'), 71.82 (C-4), 77.26 (C-5), 78.23 (C-5'), 102.46 (C-1'), 159.62 (C-2). Anal. Calcd for C₆₂H₅₁NO₁₇: C, 68.82; H, 4.75; N, 1.29. Found: C, 69.00; H, 4.68; N, 1.35.

3,6-Di-O-benzoyl-4-O-(2,3,4,6-tetra-O-benzoyl- β -D-galactopyranosyl)-1,5-anhydro-D-fructose O-(*p*-Methoxybenzoyl)oxime (6c): a colorless powder; yield: 90.4%; mp 105-109°C; $[\alpha]_D^{26} +47.1^\circ$ (c = 0.79, CHCl₃); MS (FAB) *m/z*: 1098 [M+1]⁺, 1203 [M+1+DEA]⁺; IR (KBr) ν_{\max} cm⁻¹: 1730 (C=O), 1510, 1610 (benzene); ¹H-NMR (300 MHz, CDCl₃) δ : 3.72 (1H, m, H-5), 3.87 (3H, s, OMe), 4.25 (1H, dd, H-6a), 4.32 (1H, m, H-5'), 4.40 (1H, dd, H-4), 4.41 (1H, dd, H-6b), 4.53 (1H, d, H-1a), 5.13 (1H, d, H-1e), 5.14 (1H, d, H-1'), 5.79 (1H, dd, H-3'), 5.80 (1H, dd, H-2'), 5.95 (1H, dd, H-4'), 6.32 (1H, d, H-3); $J_{1a,1e} = 16.5$, $J_{3,4} = 4.5$, $J_{4,5} = 8.5$, $J_{5,6a} = 5.0$, $J_{5,6b} = 2.5$, $J_{6a,6b} = 8.5$, $J_{1',2'} = 8.0$, $J_{2',3'} = 10.5$, $J_{3',4'} = 3.5$, $J_{4',5'} = 1.0$, $J_{vic} = 9.0$ Hz; ¹³C-NMR (75 MHz, CDCl₃) δ : 55.50 (OMe), 61.62 (C-6'), 63.21 (C-6), 64.19 (C-1), 67.86 (C-4'), 69.85 (C-2'), 71.51 (C-3), 71.61 (C-3'), 71.80 (C-5'), 102.49 (C-1'). Anal. Calcd for C₆₂H₅₁NO₁₈: C, 67.82; H, 4.68; N, 1.28. Found: C, 67.73; H, 4.69; N, 1.25.

3,6-Di-O-benzoyl-4-O-(2,3,4,6-tetra-O-benzoyl- β -D-galactopyranosyl)-1,5-anhydro-D-fructose O-(*p*-Chlorobenzoyl)oxime (6d): a colorless powder; yield: 94.3%; mp 107-110°C; $[\alpha]_D^{26} +44.9^\circ$ (c = 0.50, CHCl₃); MS (FAB) *m/z*: 1125 [M+Na]⁺, 947 [M-OBzCl+1]⁺; IR (KBr) ν_{\max} cm⁻¹: 1730 (C=O), 1600, 1490 (benzene); ¹H-NMR (300 MHz, CDCl₃) δ : 3.74 (1H, td, H-5), 4.26 (1H, m, H-6a), 4.30 (1H, m, H-5'), 4.32 (1H, m, H-6b), 4.42 (1H, m, H-6'), 4.43 (1H, dd, H-4), 4.50 (1H, d, H-1a), 5.13 (1H, d, H-1e), 5.14 (1H, d, H-1'), 5.59 (1H, dd, H-3'), 5.81 (1H, dd, H-2'), 5.92 (1H, dd, H-4'), 6.31 (1H, d, H-3); $J_{1a,1e} = 16.5$, $J_{3,4} = 4.5$, $J_{4,5} = 8.0$, $J_{5,6a} = 4.5$, $J_{5,6b} = 2.5$, $J_{1',2'} = 8.0$, $J_{2',3'} = 10.5$, $J_{3',4'} = 3.5$, $J_{4',5'} = 1.0$ Hz; ¹³C-NMR (75 MHz, CDCl₃) δ : 61.60 (C-6'), 63.13 (C-6), 64.02 (C-1), 67.84 (C-4'), 69.84 (C-2'), 71.36 (C-3), 71.56 (C-3'), 71.80 (C-5'), 77.31 (C-5), 78.07 (C-4), 102.39 (C-1'). Anal. Calcd for C₆₁H₄₈NO₁₇Cl: C, 66.45; H, 4.39; N, 1.27; Cl, 3.22. Found: C, 66.21; H, 4.37; N, 1.35; Cl, 3.27.

3,6-Di-*O*-benzoyl-4-*O*-(2,3,4,6-tetra-*O*-benzoyl- β -D-galactopyranosyl)-1,5-anhydro-D-fructose *O*-(*p*-Nitrobenzoyl)oxime (6e**):** a colorless powder; yield: 87.5%; mp 110–117°C; $[\alpha]_D^{24} +45.9^\circ$ ($c = 0.65$, CHCl_3); MS (FAB) m/z : 1136 $[\text{M}+\text{Na}]^+$; IR (KBr) ν_{max} cm^{-1} : 1320 (NO_2), 1730 ($\text{C}=\text{O}$); $^1\text{H-NMR}$ (300 MHz, CDCl_3) δ : 3.75 (1H, td, H-5), 4.27 (1H, td, H-5'), 4.29 (1H, dd, H-6'a), 4.41 (1H, dd, H-6'b), 4.42 (1H, dd, H-4), 4.44 (1H, m, H-6a), 4.46 (1H, m, H-6b), 4.51 (1H, d, H-1a), 5.13 (1H, d, H-1'), 5.15 (1H, d, H-1e), 5.59 (1H, dd, H-3'), 5.80 (1H, dd, H-2'), 5.95 (1H, dd, H-4'), 6.32 (1H, d, H-3); $J_{1a,1e} = 16.0$, $J_{3,4} = 5.0$, $J_{4,5} = 8.0$, $J_{5,6a} = 5.0$, $J_{5,6b} = 2.5$, $J_{1',2'} = 8.0$, $J_{2',3'} = 10.0$, $J_{3',4'} = 3.5$, $J_{4',5'} = 1.0$, $J_{5',6'a} = 5.0$, $J_{5',6'b} = 6.5$, $J_{6'a,6'b} = 8.0$ Hz; $^{13}\text{C-NMR}$ (75 MHz, CDCl_3) δ : 61.60 (C-6'), 63.07 (C-6), 63.91 (C-1), 67.84 (C-4'), 69.86 (C-2'), 71.27 (C-3), 71.54 (C-3'), 71.84 (C-5'), 77.20 (C-5), 77.93 (C-4), 102.35 (C-1'). Anal. Calcd for $\text{C}_{61}\text{H}_{48}\text{N}_2\text{O}_{19}$: C, 65.82; H, 4.35; N, 2.52. Found: C, 65.68; H, 4.51; N, 2.50.

3,6-Di-*O*-benzoyl-4-*O*-(2,3,4,6-tetra-*O*-benzoyl- β -D-galactopyranosyl)-1,5-anhydro-D-fructose *O*-Acetyloxime (6f**):** Acetic anhydride was used for acetylating agent, affording **6f** as a colorless powder in 90.7% yield. mp 102–105°C; $[\alpha]_D^{26} +60.0^\circ$ ($c = 0.89$, CHCl_3); MS (FAB) m/z : 1006 $[\text{M}+1]^+$, 1028 $[\text{M}+\text{Na}]^+$, 1111 $[\text{M}+1+\text{DEA}]^+$; IR (KBr) ν_{max} cm^{-1} : 1730 ($\text{C}=\text{O}$); $^1\text{H-NMR}$ (300 MHz, CDCl_3) δ : 2.16 (3H, s, OAc), 3.69 (1H, td, H-5), 4.22 (1H, dd, H-6a), 4.25 (1H, td, H-5'), 4.30 (1H, d, H-1a), 4.32 (1H, dd, H-6'a), 4.39 (1H, dd, H-4), 4.43 (1H, m, H-6b), 5.02 (1H, d, H-1e), 5.13 (1H, d, H-1'), 5.58 (1H, dd, H-3'), 5.80 (1H, dd, H-2'), 5.95 (1H, dd, H-4'), 6.21 (1H, d, H-3); $J_{1a,1e} = 16.0$, $J_{3,4} = 4.5$, $J_{4,5} = 8.0$, $J_{5,6a} = 5.0$, $J_{5,6b} = 3.0$, $J_{6a,6b} = 9.0$, $J_{1',2'} = 8.0$, $J_{2',3'} = 10.0$, $J_{3',4'} = 3.5$, $J_{4',5'} = 1.0$, $J_{5',6'a} = 5.0$, $J_{5',6'b} = 3.0$, $J_{6'a,6'b} = 9.0$ Hz; $^{13}\text{C-NMR}$ (75 MHz, CDCl_3) δ : 19.43 (OAc), 61.70 (C-6'), 63.11 (C-6), 63.94 (C-1), 67.86 (C-4'), 69.82 (C-2'), 71.35 (C-3), 71.56 (C-3'), 71.80 (C-5'), 77.21 (C-5), 78.00 (C-4), 102.3 (C-1'). Anal. Calcd for $\text{C}_{56}\text{H}_{47}\text{NO}_{17}$: C, 66.86; H, 4.71; N, 1.39. Found: C, 66.79; H, 4.71; N, 1.27.

3,6-Di-*O*-benzoyl-2-(*p*-methylbenzoyloxyimino)-4-*O*-(2,3,4,6-tetra-*O*-benzoyl- β -D-galactopyranosyl)- α -D-arabino-hexopyranosyl Bromide (7b**):** A mixture of *p*-methoxybenzoyloxime (**6b**) (541 mg, 0.500 mmol) and freshly recrystallized *N*-bromosuccinimide (93.5 mg, 0.525 mmol) in tetrachloromethane (15 mL) was irradiated with a 450W heat lamp such that gentle reflux was effected (distance of the lamp from the bottom of the flask, 10–15 cm). After 30 min the resulting yellowish solution was cooled (0°C), the precipitate (succinimide) was filtered off, and the filtrate was partitioned between dichloromethane (50 mL) and water (50 mL). The organic phase was washed with water (2 x 50 mL), dried (Na_2SO_4), and evaporated to a syrup, which crystallized by trituration with ether-pentane to give 500 mg (86.1%) of **7b**: mp 103–108°C; $[\alpha]_D^{19} +163^\circ$ ($c = 0.73$, CHCl_3); MS (FAB) m/z : 1161 $[\text{M}+1]^+$, 1183 $[\text{M}+\text{Na}]^+$; IR (KBr) ν_{max} cm^{-1} : 1730 ($\text{C}=\text{O}$); $^1\text{H-NMR}$ (300 MHz, CDCl_3) δ : 2.41 (3H, s, CH_3), 3.96 (1H, td, H-5'), 3.98 (1H, dd, H-6'a), 4.09 (1H, dd, H-6'b), 4.10 (1H, dd, H-6a), 4.48 (1H, td, H-5), 4.60 (1H, dd, H-4), 4.71 (1H, dd, H-6 b), 5.05 (1H, d, H-1'), 5.46 (1H, dd, H-3'), 5.79 (1H, dd, H-2'), 5.81 (1H, dd, H-4'), 6.62 (1H, d, H-3), 7.26 (1H, s, H-1); $J_{3,4} = 9.0$, $J_{4,5} = 10.0$, $J_{5,6a} = 7.0$, $J_{5,6b} = 2.0$, $J_{6a,6b} = 12.0$, $J_{1',2'}$

= 8.0, $J_{2,3'} = 10.0$, $J_{3',4'} = 3.5$, $J_{4',5'} = 1.0$, $J_{5',6'a} = 7.5$, $J_{5',6'b} = 5.0$, $J_{6'a,6'b} = 8.5$ Hz; $^{13}\text{C-NMR}$ (75 MHz, CDCl_3) δ : 21.70 (CH_3), 60.91 (C-6'), 61.15 (C-6), 67.34 (C-4'), 68.92 (C-3), 69.79 (C-2'), 71.48 (C-5'), 71.58 (C-3'), 73.38 (C-5), 73.59 (C-2), 75.07 (C-4), 77.16 (C-1), 101.09 (C-1'). Anal. Calcd for $\text{C}_{62}\text{H}_{50}\text{NO}_{17}\text{Br}$: C, 64.14; H, 4.34; N, 1.21; Br, 6.88. Found: C, 63.99; H, 4.32; N, 1.32; Br, 7.15.

3,6-Di-O-benzoyl-2-(*p*-methoxybenzoyloxyimino)-2-deoxy-4-O-(2,3,4,6-tetra-O-benzoyl- β -D-galactopyranosyl)- α -D-arabino-hexopyranosyl Bromide (7c): *p*-Methoxybenzoyloxime (**6c**) was exposed to photobromination as described for **7b** to give **7c** as a colorless powder in 90.5% yield. mp 118-120°C; $[\alpha]_{\text{D}}^{23} +182^\circ$ ($c = 0.64$, CHCl_3); MS (FAB) m/z : 1178 $[\text{M}+1]^+$, 1283 $[\text{M}+1+\text{DEA}]^+$; IR (KBr) ν_{max} cm^{-1} : 1730 (C=O), 1600, 1510 (benzene); $^1\text{H-NMR}$ (300 MHz, CDCl_3) δ : 3.86 (3H, s, OMe), 3.90 (1H, td, H-5'), 3.92 (1H, dd, H-6'a), 4.09 (1H, dd, H-6'b), 4.47 (1H, m, H-6a), 4.49 (1H, td, H-5), 4.60 (1H, dd, H-4), 4.71 (1H, dd, H-6b), 5.04 (1H, d, H-1'), 5.46 (1H, dd, H-3'), 5.78 (1H, dd, H-2'), 5.80 (1H, dd, H-4'), 6.60 (1H, d, H-3); $J_{3,4} = J_{4,5} = 9.5$, $J_{5,6'a} = 3.0$, $J_{5,6'b} = 2.0$, $J_{6'a,6'b} = 12.0$, $J_{1',2'} = 8.0$, $J_{2',3'} = 10.5$, $J_{3',4'} = 3.5$, $J_{4',5'} = 1.0$, $J_{5',6'a} = 5.0$, $J_{5',6'b} = 2.0$, $J_{6'a,6'b} = 11.0$, $J_{\text{vic}} = 9.0$ Hz; $^{13}\text{C-NMR}$ (75 MHz, CDCl_3) δ : 55.49 (OMe), 60.96 (C-6'), 61.22 (C-6), 67.39 (C-4'), 68.98 (C-3), 69.86 (C-2'), 71.53 (C-5'), 71.63 (C-3'), 73.42 (C-5), 73.71 (C-1), 75.13 (C-4), 101.15 (C-1'). Anal. Calcd for $\text{C}_{62}\text{H}_{50}\text{NO}_{18}\text{Br}$: C 63.27, H 4.28, N 1.19, Br 6.79; Found: C 63.16, H 4.40, N 1.15, Br 6.52.

3,6-Di-O-benzoyl-2-(*p*-chlorobenzoyloxyimino)-2-deoxy-4-O-(2,3,4,6-tetra-O-benzoyl- β -D-galactopyranosyl)- α -D-arabino-hexopyranosyl Bromide (7d): a colorless powder; yield: 94.4%; mp 117-122°C; $[\alpha]_{\text{D}}^{23} +179^\circ$ ($c = 0.59$, CHCl_3); MS (FAB) m/z : 1100 $[\text{M}-\text{Br}]^+$, 1123 $[\text{M}+1+\text{Na}]^+$; IR (KBr) ν_{max} cm^{-1} : 1730 (C=O), 1600, 1510 (benzene); $^1\text{H-NMR}$ (300 MHz, CDCl_3) δ : 3.93 (1H, m, H-5'), 3.98 (1H, dd, H-6'a), 4.10 (1H, dd, H-6'b), 4.45 (1H, m, H-5), 4.51 (1H, dd, H-6a), 4.60 (1H, dd, H-4), 4.71 (1H, dd, H-6b), 5.05 (1H, d, H-1'), 5.47 (1H, dd, H-3'), 5.79 (1H, dd, H-2'), 5.82 (1H, dd, H-4'), 6.60 (1H, d, H-3); $J_{3,4} = J_{4,5} = 9.0$, $J_{5,6'a} = 5.0$, $J_{5,6'b} = 2.0$, $J_{6'a,6'b} = 12.0$, $J_{1',2'} = 8.0$, $J_{2',3'} = 10.0$, $J_{3',4'} = 3.5$, $J_{4',5'} = 1.0$, $J_{5',6'b} = 3.5$, $J_{6'a,6'b} = 9.0$ Hz; $^{13}\text{C-NMR}$ (75 MHz, CDCl_3) δ : 60.97 (C-6'), 61.15 (C-6), 67.39 (C-4'), 68.97 (C-3), 69.85 (C-2'), 71.55 (C-5'), 71.61 (C-3'), 73.46 (C-5), 75.05 (C-4), 101.15 (C-1'). Anal. Calcd for $\text{C}_{61}\text{H}_{47}\text{NO}_{17}\text{ClBr}$: C, 62.02; H, 4.01; N, 1.19. Found: C, 62.15; H, 4.00; N, 1.41.

3,6-Di-O-benzoyl-2-(*p*-nitrobenzoyloxyimino)-2-deoxy-4-O-(2,3,4,6-tetra-O-benzoyl- β -D-galactopyranosyl)- α -D-arabino-hexopyranosyl Bromide (7e): a colorless amorphous powder; yield: 91.9%; $[\alpha]_{\text{D}}^{25} +159^\circ$ ($c = 0.81$, CHCl_3); MS (FAB) m/z : 1191 $[\text{M}]^+$, 1214 $[\text{M}+\text{Na}]^+$; IR(KBr) ν_{max} cm^{-1} : 1730 (C=O), 1530, 1350 (NO_2); $^1\text{H-NMR}$ (300 MHz, CDCl_3) δ : 3.90 (1H, m, H-5'), 4.10 (1H, m, H-6'a), 4.14 (1H, m, H-6'b), 4.45 (1H, m, H-6a), 4.47 (1H, td, H-5), 4.61 (1H, dd, H-4), 4.72 (1H, dd, H-6b), 5.05 (1H, d, H-1'), 5.48 (1H, dd, H-3'), 5.79 (1H, dd, H-2'), 5.82 (1H, dd, H-4'), 6.60 (1H, d, H-3); $J_{3,4} = J_{4,5} = 9.2$, $J_{5,6'a} = 4.0$, $J_{5,6'b} = 2.5$, $J_{6'a,6'b} = 12.5$, $J_{1',2'} = 8.0$, $J_{2',3'} = 10.5$, $J_{3',4'} = 3.5$, $J_{4',5'} = 1.0$, $J_{6'a,6'b} = 10.0$ Hz; $^{13}\text{C-NMR}$ (75 MHz, CDCl_3) δ : 60.97 (C-6'), 61.11 (C-6), 67.39 (C-4'), 68.98 (C-3), 69.86 (C-2'), 71.58 (C-3', C-5'),

73.22 (C-5), 73.55 (C-1), 74.96 (C-4), 101.18 (C-1'). Anal. Calcd for C₆₁H₄₇N₂O₁₉Br: C, 61.47; H, 3.97; N, 2.35; Br, 6.70. Found: C, 61.76; H, 3.97; N, 2.42; Br, 6.36.

3,6-Di-O-benzoyl-2-acetoxymino-2-deoxy-4-O-(2,3,4,6-tetra-O-benzoyl-β-D-galactopyranosyl)-α-D-arabino-hexopyranosyl Bromide (7f): a colorless powder; yield: 85.5%; mp 108-112°C; [α]_D¹⁹ +119° (c = 0.92, CHCl₃); MS (FAB) *m/z*: 1084 [M]⁺; IR (KBr) ν_{\max} cm⁻¹: 1730 (C=O); ¹H-NMR (300 MHz, CDCl₃) δ : 2.13 (3H, s, OAc), 3.93 (1H, td, H-5'), 3.98 (1H, dd, H-6'a), 4.12 (1H, dd, H-6'b), 4.44 (1H, td, H-5), 4.49 (1H, m, H-6a), 4.55 (1H, dd, H-4), 4.69 (1H, dd, H-6b), 5.02 (1H, d, H-1'), 5.46 (1H, dd, H-3'), 5.77 (1H, dd, H-2'), 5.81 (1H, dd, H-4'), 6.52 (1H, d, H-3), 7.26 (1H, s, H-1); $J_{3,4} = 9.0$, $J_{4,5} = 10.0$, $J_{5,6a} = 4.0$, $J_{5,6b} = 2.0$, $J_{6a,6b} = 12.0$, $J_{1,2'} = 8.0$, $J_{2',3'} = 10.5$, $J_{3',4'} = 3.5$, $J_{4',5'} = 1.0$, $J_{5',6'a} = 8.0$, $J_{5',6'b} = 5.0$, $J_{6'a,6'b} = 8.0$ Hz; ¹³C-NMR (75 MHz, CDCl₃) δ : 19.37 (OAc), 60.99 (C-6'), 61.17 (C-6), 67.37 (C-4'), 68.98 (C-3), 69.81 (C-2'), 71.51 (C-5'), 71.62 (C-3'), 73.39 (C-1), 73.42 (C-5), 75.07 (C-4), 101.09 (C-1'). Anal. Calcd for C₅₆H₄₆NO₁₇Br: C, 62.00; H, 4.27; N, 1.29; Br, 7.37. Found: C, 62.30; H, 4.35; N, 1.33; Br, 7.09.

***p*-Methoxybenzyl 3,6-Di-O-benzoyl-2-(*p*-methylbenzoyloxyimino)-2-deoxy-4-O-(2,3,4,6-tetra-O-benzoyl-β-D-galactopyranosyl)-α-D-arabino-hexopyranoside (1b)**: A mixture of *p*-methoxybenzyl alcohol (242 mg, 1.75 mmol), powdered molecular sieves 3A (180 mg), and iodine (88.8 mg, 0.35 mmol) in dry 1,2-dimethoxyethane (3.5 mL) was stirred in the dark at rt for 1 h. Then oximinoglycosyl bromide (**7b**) (406 mg, 0.35 mmol) and *s*-collidine (0.0463 mL, 0.35 mmol) were added to the mixture, which was stirred at ambient temperature for 2 d. The resulting mixture was diluted with CH₂Cl₂ (200 mL) and filtered through a pad of Celite. The filtrate was washed with aqueous 0.1 M Na₂S₂O₃ (25 mL), water (25 mL), 5% NaHCO₃ (25 mL), and water (3 x 25 mL). After drying (Na₂SO₄), the solvent was removed to give **1b** as a syrup, which can be used for the reduction process without further purification. For analytical purposes, the syrupy product was purified by elution from a silica gel column with 6:1 toluene-EtOAc to afford 358 mg (84%) of **1b** as a white powder (α : β = 10:1, ¹H-NMR): mp 103-105°C (EtOAc-Et₂O-pentane); [α]_D²⁵ +89.1° (c = 0.62, CHCl₃); MS (FAB) *m/z*: 1080 [M-OMBn]⁺, 1240 [M+Na]⁺; ¹H-NMR (300 MHz, CDCl₃) δ : 2.38 (3H, s, CH₃), 3.75 (3H, s, OMe), 3.88 (1H, td, H-5'), 4.00 (1H, dd, H-6'a), 4.09 (1H, dd, H-6'b), 4.42 (1H, td, H-5), 4.47 (1H, dd, H-6a), 4.49 (1H, dd, H-4), 4.58, 4.76 (each 1H, d, CH₂Ph), 4.67 (1H, dd, H-6b), 5.02 (1H, d, H-1'), 5.43 (1H, dd, H-3'), 5.68 (1H, dd, H-2'), 5.80 (1H, dd, H-4'), 6.03 (1H, s, H-1), 6.43 (1H, d, H-3); $J_{3,4} = 9.0$, $J_{4,5} = 10.0$, $J_{5,6a} = 8.0$, $J_{5,6b} = 2.0$, $J_{6a,6b} = 11.5$, $J_{1,2'} = 8.0$, $J_{2',3'} = 10.5$, $J_{3',4'} = 3.5$, $J_{4',5'} = 1.0$, $J_{5',6'a} = 8.0$, $J_{5',6'b} = 5.5$, $J_{6'a,6'b} = 11.0$, $J_{\text{vic}} = 9.0$, $J_{\text{gem}} = 12.0$ Hz; ¹³C-NMR (75 MHz, CDCl₃) δ : 21.69 (Bz-CH₃), 55.05 (OMe), 60.86 (C-6'), 62.08 (C-6), 67.38 (C-4'), 68.59 (CH₂Ph), 68.94 (C-5), 69.96 (C-2'), 70.42 (C-3), 71.40 (C-5'), 71.69 (C-3'), 77.63 (C-4), 88.69 (C-1), 101.3 (C-1'). Anal. Calcd for C₇₀H₅₉NO₁₉: C, 69.01; H, 4.88; N, 1.15. Found: C, 68.57; H, 4.74; N, 1.17.

***p*-Methoxybenzyl 3,6-Di-*O*-benzoyl-2-(*p*-methoxybenzoyloxyimino)-2-deoxy-4-*O*-(2,3,4,6-tetra-*O*-benzoyl- β -D-galactopyranosyl)- α -D-arabino-hexopyranoside (1c):** a colorless powder; yield: 80.2%; mp 101-103°C; $[\alpha]_D^{25} +98.3^\circ$ ($c = 0.65$, CHCl₃); MS (FAB) m/z : 1256 [M+Na]⁺, 1096 [M-NOBzOMe]⁺; IR (KBr) ν_{\max} cm⁻¹: 1730 (C=O), 1610, 1510 (benzene); ¹H-NMR (300 MHz, CDCl₃) δ : 2.98, 3.85 (each 3H, s, OMe), 3.90 (1H, m, H-5'), 4.00 (1H, dd, H-6'a), 4.99 (1H, dd, H-6'b), 4.43 (1H, td, H-5), 4.50 (1H, dd, H-4), 4.51 (1H, dd, H-6), 4.58, 4.76 (each 1H, d, CH₂Ph), 4.68 (1H, dd, H-6b), 5.03 (1H, d, H-1'), 5.46 (1H, dd, H-3'), 5.76 (1H, dd, H-2'), 5.80 (1H, dd, H-4'), 6.02 (1H, s, H-1), 6.42 (1H, d, H-3); $J_{3,4} = 9.0$, $J_{4,5} = 9.5$, $J_{5,6a} = 5.0$, $J_{5,6b} = 3.0$, $J_{6a,6b} = 12.0$, $J_{1',2'} = 8.0$, $J_{2',3'} = 10.5$, $J_{3',4'} = 3.5$, $J_{4',5'} = 1.0$, $J_{5',6'a} = 8.0$, $J_{5',6'b} = 5.0$, $J_{6'a,6'b} = 10.5$, $J_{\text{gem}} = 12.0$ Hz; ¹³C-NMR (75 MHz, CDCl₃) δ : 55.15, 55.35 (2×OMe), 60.85 (C-6'), 62.08 (C-6), 67.39 (C-4'), 68.43 (CH₂Ph), 68.93 (C-5), 69.97 (C-2'), 70.43 (C-3), 71.39 (C-5'), 71.69 (C-3'), 77.63 (C-4), 88.53 (C-1), 101.24 (C-1'). Anal. Calcd for C₇₀H₅₉NO₂₀: C, 68.12; H, 4.82; N, 1.13. Found: C, 67.77; H, 4.83; N, 1.15.

***p*-Methoxybenzyl 3,6-Di-*O*-benzoyl-2-(*p*-chlorobenzoyloxyimino)-2-deoxy-4-*O*-(2,3,4,6-tetra-*O*-benzoyl- β -D-galactopyranosyl)- α -D-arabino-hexopyranoside (1d):** a colorless powder; yield: 83.3%; mp 106-110°C; $[\alpha]_D^{24} +97.8^\circ$ ($c = 0.26$, CHCl₃); MS (FAB) m/z : 1238 [M+1]⁺, 1260 [M+Na]⁺; IR (KBr) ν_{\max} cm⁻¹: 1730 (C=O), 1600, 1520 (benzene); ¹H-NMR (300 MHz, CDCl₃) δ : 3.76 (3H, s, OMe), 3.89 (1H, td, H-5'), 4.00 (1H, dd, H-6'a), 4.11 (1H, dd, H-6'b), 4.41 (1H, m, H-5), 4.48 (1H, dd, H-6a), 4.50 (1H, dd, H-4), 4.69 (1H, dd, H-6b), 4.56, 4.76 (each 1H, d, CH₂Ph), 5.03 (1H, d, H-1'), 5.47 (1H, dd, H-3'), 5.77 (1H, dd, H-2'), 5.81 (1H, dd, H-4'), 5.98 (1H, s, H-1), 6.43 (1H, d, H-3); $J_{3,4} = 9.0$, $J_{4,5} = 9.5$, $J_{5,6a} = 5.5$, $J_{5,6b} = 2.5$, $J_{6a,6b} = 12.0$, $J_{1',2'} = 8.0$, $J_{2',3'} = 10.5$, $J_{3',4'} = 3.5$, $J_{4',5'} = 1.0$, $J_{5',6'a} = 8.0$, $J_{5',6'b} = 6.0$, $J_{6'a,6'b} = 11.0$, $J_{\text{vic}} = 12.0$ Hz; ¹³C-NMR (75 MHz, CDCl₃) δ : 55.06 (OMe), 60.86 (C-6'), 62.02 (C-6), 67.37 (C-4'), 68.33 (CH₂Ph), 68.95 (C-5), 69.95 (C-2'), 70.38 (C-3), 71.40 (C-5'), 71.66 (C-3'), 77.56 (C-4), 88.24 (C-1), 101.24 (C-1'). Anal. Calcd for C₆₉H₅₆NO₁₉Cl: C, 66.91; H, 4.56; N, 1.13; Cl, 2.86. Found: C, 66.62; H, 4.49; N, 1.20; Cl, 3.05.

***p*-Methoxybenzyl 3,6-Di-*O*-benzoyl-2-(*p*-nitrobenzoyloxyimino)-2-deoxy-4-*O*-(2,3,4,6-tetra-*O*-benzoyl- β -D-galactopyranosyl)- α -D-arabino-hexopyranoside (1e):** a colorless powder; yield: 81.8%; mp 113-114°C; $[\alpha]_D^{24} +86.2^\circ$ ($c = 1.21$, CHCl₃); MS (FAB) m/z : 1271 [M+Na]⁺; IR (KBr) ν_{\max} cm⁻¹: 1730 (C=O), 1530, 1350 (NO₂); ¹H-NMR (300 MHz, CDCl₃) δ : 3.79 (3H, s, OMe), 4.47 (1H, m, H-4), 4.56, 4.77 (each 1H, d, CH₂Ph), 5.04 (1H, d, H-1'), 5.48 (1H, dd, H-3'), 5.77 (1H, dd, H-2'), 5.82 (1H, dd, H-4'), 5.96 (1H, s, H-1), 6.44 (1H, d, H-3), 6.84 (2H, d, Ph-OMe); $J_{3,4} = 9.2$, $J_{1',2'} = 8.0$, $J_{2',3'} = 10.5$, $J_{3',4'} = 3.5$, $J_{4',5'} = 1.0$, $J_{\text{gem}} = 12.5$ Hz; ¹³C-NMR (75 MHz, CDCl₃) δ : 55.13 (OMe), 60.88 (C-6'), 61.97 (C-6), 67.38 (C-4'), 68.16 (CH₂Ph), 68.99 (C-5), 69.97 (C-2'), 70.36 (C-3), 71.43 (C-5'), 71.63 (C-3'), 77.51 (C-4), 87.94 (C-1), 101.26 (C-1'), 114.08 (Ph); Anal. Calcd for C₆₉H₅₆N₂O₂₁: C, 66.34; H, 4.52; N, 2.24. Found: C, 65.92; H, 4.56; N, 2.24.

p-Methoxybenzyl **3,6-Di-*O*-benzoyl-2-acetoxyimino-2-deoxy-4-*O*-(2,3,4,6-tetra-*O*-benzoyl- β -D-galactopyranosyl)- α -D-arabino-hexopyranoside (1f)**: a colorless powder; yield 82.5%; mp 97-100°C; $[\alpha]_D^{19} +87.3^\circ$ ($c = 0.85$, CHCl_3); MS (FAB) m/z : 1143 $[\text{M}+1]^+$, 1164 $[\text{M}+\text{Na}+1]^+$; IR (KBr) ν_{max} cm^{-1} : 1730 (C=O), 1600, 1520 (benzene); $^1\text{H-NMR}$ (300 MHz, CDCl_3) δ : 1.95 (3H, s, OAc), 3.80 (3H, s, OMe), 3.90 (1H, td, H-5'), 4.00 (1H, dd, H-6'a), 4.11 (1H, dd, H-6'b), 4.35 (1H, td, H-5), 4.43 (1H, dd, H-6a), 4.44 (1H, dd, H-4), 4.58, 4.71 (each 1H, d, CH_2Ph), 4.65 (1H, dd, H-6b), 5.01 (1H, d, H-1'), 5.47 (1H, dd, H-3'), 5.75 (1H, dd, H-2'), 5.81 (1H, dd, H-4'), 5.94 (1H, s, H-1), 6.31 (1H, d, H-3), 6.87 (2H, d, Ph); $J_{3,4} = 9.0$, $J_{4,5} = 9.5$, $J_{5,6a} = 7.0$, $J_{5,6b} = 2.0$, $J_{6a,6b} = 5.5$, $J_{1,2'} = 8.0$, $J_{2',3'} = 10.0$, $J_{3,4'} = 3.5$, $J_{4,5'} = 1.0$, $J_{5',6a} = 7.5$, $J_{5',6b} = 5.0$, $J_{6'a,6'b} = 11.0$, $J_{\text{vic}} = 9.0$, $J_{\text{gem}} = 12.0$ Hz; $^{13}\text{C-NMR}$ (75 MHz, CDCl_3) δ : 19.27 (OAc), 55.27 (OMe), 60.89 (C-6'), 61.96 (C-6), 67.34 (C-4'), 68.82 (C-5), 69.64 (CH_2Ph), 69.86 (C-2'), 70.32 (C-3), 71.34 (C-5'), 71.62 (C-3'), 77.29 (C-4), 89.63 (C-1), 101.17 (C-1'). Anal. Calcd for $\text{C}_{64}\text{H}_{55}\text{NO}_{19}$: C, 67.30; H, 4.85; N, 1.23. Found: C, 67.14; H, 4.95; N, 1.28.

p-Methoxybenzyl **2-Acetamido-3,6-di-*O*-benzoyl-4-*O*-(2,3,4,6-tetra-*O*-benzoyl- β -D-galactopyranosyl)-2-deoxy- α -D-glucopyranoside (9), its 3-*O*-debenzoylated analog (10), and α -D-manno analog (11)**: A solution of α -glycoside **1d** (248 mg, 0.2 mmol) in dry THF (2.4 mL) was treated at -10°C with a 1 M solution of $\text{BH}_3 \cdot \text{THF}$ complex (2.4 mL) under an atmosphere of nitrogen. The mixture was stirred for 0.5 h and then allowed to attain rt. After stirring for 2 h, excess reagent was quenched at 0°C with MeOH (4 mL), followed by addition of Ac_2O (2 mL). After stirring for 1 h at ambient temperature, the mixture passed through Amberlite IR-45 resin (6 g) and washed with MeOH. The eluants and washings were concentrated in vacuo to a syrup, which was eluted from a silica gel column with toluene-EtOAc (1:1 \rightarrow 1:2). The major fraction was concentrated and solidified from EtOAc-Et₂O-pentane (1:2:4) to provide 104 mg (46%) of **9** as a colorless powder: mp 99-102°C; $[\alpha]_D^{21} +80.5^\circ$ ($c = 0.53$, CHCl_3); MS (FAB) m/z : 1128 $[\text{M}+1]^+$, 1150 $[\text{M}+\text{Na}]^+$; $^1\text{H-NMR}$ and $^{13}\text{C-NMR}$ spectral data were identified with the reported data.⁸

The second fraction gave 53 mg (25.6%) of pentabenzoate (**10**): mp 96-98°C; $[\alpha]_D^{21} +124.3^\circ$ ($c = 0.52$, CHCl_3); MS (FAB) m/z : 1024 $[\text{M}+1]^+$, 1046 $[\text{M}+\text{Na}]^+$; $^1\text{H-NMR}$ and $^{13}\text{C-NMR}$ spectral data were identified with the reported data.⁸

The third fraction gave a residue, which was identified as the corresponding α -D-manno analog (**11**) (12.6 mg, 5.6%) in all respects with the reported data.⁸

2-Acetamido-3,6-di-*O*-benzoyl-4-*O*-(2,3,4,6-tetra-*O*-benzoyl- β -D-galactopyranosyl)-2-deoxy- α -D-glucopyranose (12): To a solution of **9** (400 mg, 0.36 mmol) in acetonitrile-water (9:1, 7 mL) was added 390 mg (0.71 mmol) of cerium ammonium nitrate (CAN). The mixture was stirred at rt for 20 h, diluted with dichloromethane (70 mL), washed with 5% aqueous NaHCO_2 (2 x 70 mL), and water (3 x 70 mL), dried (Na_2SO_4), and evaporated in vacuo to dryness. The residue was eluted through a silica gel column

with CHCl_3 -EtOAc (1:2). Concentration of the major fraction gave a syrup which crystallized from ethyl acetate-ether-pentane, affording 282 mg (78.8%) of **12** as colorless crystals; mp 142-144°C; $[\alpha]_{\text{D}}^{24} +40.4^\circ$ ($c = 0.27$, CHCl_3); MS (FAB) m/z : 1008 $[\text{M}+1]^+$, 1030 $[\text{M}+\text{Na}]^+$; IR (KBr) ν_{max} cm^{-1} : 3420 (OH), 1730 (C=O), 1610, 1490 (benzene); $^1\text{H-NMR}$ (300 MHz, CDCl_3) δ : 3.96 (1H, dd, H-6'a), 4.01 (1H, td, H-5'), 4.06 (1H, dd, H-6'b), 4.19 (1H, dd, H-6a), 4.22 (1H, dd, H-6b), 4.25 (1H, td, H-5), 4.28 (1H, dd, H-4), 4.72 (1H, dq, H-2), 4.77 (1H, d, H-1'), 4.99 (1H, d, OH), 5.53 (1H, d, H-1), 5.58 (1H, dd, H-3'), 5.60 (1H, dd, H-2'), 5.76 (1H, dd, H-4'), 6.30 (1H, dd, H-3); $J_{1,2} = 3.0$, $J_{2,3} = 11.0$, $J_{3,4} = 8.0$, $J_{4,5} = 10.0$, $J_{5,6a} = 3.0$, $J_{5,6b} = 2.0$, $J_{6a,6b} = 12.0$, $J_{1',2'} = 7.5$, $J_{2',3'} = 10.0$, $J_{3',4'} = 3.0$, $J_{4',5'} = 1.0$, $J_{5',6'a} = 6.0$, $J_{5',6'b} = 4.0$, $J_{6'a,6'b} = 8.5$, $J_{1,\text{OH}} = 5.0$, $J_{2,\text{NH}} = 9.5$ Hz; $^{13}\text{C-NMR}$ (75 MHz, CDCl_3) δ : 23.12 (NHAc), 52.16 (C-2), 61.16 (C-6'), 62.57 (C-6), 67.45 (C-4'), 68.65 (C-5), 70.54 (C-3'), 70.94 (C-2'), 71.49 (C-5'), 71.57 (C-3), 75.59 (C-4), 92.04 (C-1), 101.08 (C-1').

2-Acetamido-3,6-di-O-benzoyl-4-O-(2,3,4,6-tetra-O-benzoyl- β -D-galactopyranosyl)-2-deoxy- α -D-glucopyranosyl Chloride (2): To a stirred solution of **12** (174 mg, 0.173 mmol) in dry dichloromethane (1.3 mL) were added, under ice-cooling, thionyl chloride (0.052 mL, 0.692 mmol) and DMF (8 μL , 0.103 mmol). The mixture was stirred at rt for 20 h, and then filtered through a pad of silica gel (100 mg). The filtrate was evaporated in vacuo to give a residue, which was eluted through a silica gel column with CHCl_3 -EtOAc (3:1). Concentration of the major fraction and crystallization from ethyl acetate-ether-pentane gave 128 mg (72%) of **2** as a colorless powder: mp 127-130°C; $[\alpha]_{\text{D}}^{26} +82.2^\circ$ ($c = 0.83$, CHCl_3); MS (FAB) m/z : 990 $[\text{M}-\text{Cl}]^+$, 1026 $[\text{M}+1]^+$, 1013 $[\text{M}+990+\text{Na}]^+$, 1048 $[\text{M}+\text{Na}]^+$; $^1\text{H-NMR}$ (300 MHz, CDCl_3) δ : 1.92 (3H, s, NAc), 3.86 (1H, m, H-5'), *ca.* 4.0 (2H, dd, H-6'a and 6'b), 4.33 (1H, dd, H-4), 4.67 (1H, m, H-2), 4.95 (1H, d, H-1'), 6.20 (1H, dd, H-1), 5.74 (1H, dd, H-3), 5.42 (1H, dd, H-3'), 5.71 (1H, dd, H-2'), 5.78 (1H, dd, H-4'), 6.01 (1H, d, NH); $J_{1,2} = 3.5$, $J_{2,\text{NH}} = 8.5$, $J_{2,3} = 11.0$, $J_{1',2'} = 8.0$, $J_{2',3'} = 10.5$, $J_{3',4'} = 3.5$, $J_{4',5'} = 1.0$; $^{13}\text{C-NMR}$ (75 MHz, CDCl_3) δ : 23.09 (NHAc), 53.81 (C-2), 61.03 (C-6'), 61.45 (C-6), 67.36 (C-4'), 69.81 (C-2'), 71.70 (C-3'), 70.75 (C-3), 71.43 (C-5'), 71.87 (C-4), 74.68 (C-5), 93.65 (C-1), 100.08 (C-1').

[4-O-(2,3,4,6-Tetra-O-benzoyl- β -D-galactopyranosyl)-3,6-di-O-benzoyl-D-glucopyranose]-2-methyl-[2,1-*d*]-2-oxazoline (3) - Method A (AgOTf-TMU-promoted cyclization): To a stirred solution of **2** (102.5 mg, 100 μmol) in dry dichloromethane (2 mL) with molecular sieves 3A (200 mg) were added in the dark AgOTf (65 mg, 260 μmol) and TMU (24 μL , 200 μmol). The mixture was stirred at rt for 20 h, diluted with dichloromethane (10 mL), and filtered through a pad of Celite. The filtrate was washed with 0.05 M HCl, water, 5% aq. NaHCO_3 , and water, then dried (Na_2SO_4) and concentrated to dryness. The residue was eluted from a silica gel column with CHCl_3 -EtOAc (2:1). Concentration of the major fraction followed by crystallization from ethyl acetate-ether-pentane afforded 83.1 mg (84%) of **3** as a colorless powder: mp 101-103°C; $[\alpha]_{\text{D}}^{25} +81.4^\circ$ ($c = 0.51$, CHCl_3); MS (FAB) m/z : 990 $[\text{M}+1]^+$; $^1\text{H-NMR}$

(300 MHz, CDCl₃) δ : 2.16 (3H, d, CH₃), 3.64 (1H, td, H-5), 4.08 (1H, dd, H-6a), 4.15 (1H, dd, H-4), 4.28 (1H, dd, H-2), 4.31 (1H, dd, H-6b), 4.51 (1H, dd, H-6'a), 4.52 (1H, td, H-5'), 4.60 (1H, dd, H-6'b), 5.18 (1H, d, H-1'), 5.62 (1H, dd, H-3'), 5.84 (1H, dd, H-2'), 6.00 (1H, dd, H-4'), 6.03 (1H, d, H-1), 6.06 (1H, dd, H-3); $J_{1,2} = 7.5$, $J_{2,3} = 2.5$, $J_{3,4} = 2.0$, $J_{4,5} = 9.0$, $J_{5,6a} = 4.0$, $J_{5,6b} = 2.0$, $J_{6a,6b} = 12.0$, $J_{1,2'} = 8.0$, $J_{2',3'} = 10.0$, $J_{3',4'} = 3.5$, $J_{4,5'} = 1.0$, $J_{5',6'a} = 5.0$, $J_{5',6'b} = 9.0$, $J_{6'a,6'b} = 12.5$ Hz; ¹³C-NMR (75 MHz, CDCl₃) δ : 14.06 (CH₃), 62.22 (C-6'), 63.21 (C-6), 64.79 (C-2), 67.79 (C-5), 68.23 (C-4'), 69.77 (C-2'), 70.89 (C-3), 71.78 (C-5'), 71.83 (C-3'), 77.73 (C-4), 99.38 (C-1), 103.19 (C-1').

Method B (AgF-promoted cyclization): A mixture of the chloride (**2**) (102.5 mg, 100 μ mol) and AgF (25.5 mg, 200 μ mol) in acetonitrile (2 mL) was stirred in the dark at rt overnight. The resulting mixture was diluted with EtOAc (10 mL) and filtered through a pad of Celite. The filtrate was washed with 5% aq. NaCl and water, dried (Na₂SO₄), and evaporated to dryness. The residue was eluted from a silica gel column with CHCl₃-EtOAc (2:1). From the major fraction 74.2 mg (75%) of **3** was obtained. The product was identified in all respects with the authentic sample produced by the method A.

ACKNOWLEDGEMENT

We thank Mr. Jun-ichi Yokoyama, Ms. Keiko Okonogi, Yuri Okazaki, Emiko Nakayama, and Tomoko Shimizu for assistance in some experiments. Financial support from the Sasagawa Promotion of Science Fund (to Y. O.) by Japan Science Society is gratefully acknowledged.

REFERENCES AND NOTES

1. A. Veyrieres, *J. Chem. Soc., Perkin Trans. I*, **1981**, 1626; T. Takamura, T. Chiba, and S. Tejima, *Chem. Pharm. Bull.*, 1981, **29**, 2270; T. Furuike, N. Nishi, S. Tokura, and S.-I. Nishimura, *Chem. Lett.*, 1995, 823; T. Furuike, N. Nishi, S. Tokura, and S.-I. Nishimura, *Macromolecules*, 1995, **28**, 7241; G. Range, R. Krämer, P. Welzel, D. Müller, G. F. Herrmann, U. Kragl, C. Wandrey, A. Markus, Y. van Heijenoort, and J. van Heijenoort, *Tetrahedron*, 1997, **53**, 1695; T. Furuike, S. Aiba, T. Suzuki, T. Takahashi, Y. Suzuki, K. Yamada, and S.-I. Nishimura, *J. Chem. Soc., Perkin Trans. I*, **2000**, 3000; S.-I. Shoda, M. Fujita, C. Lohavisavapanichi, Y. Misawa, K. Ushizaki, Y. Tawata, M. Kuriyama, M. Kohri, and H. Kuwata, *Helv. Chim. Acta*, 2002, **85**, 3919; K. Matsuoka, T. Ohtawa, H. Hinou, T. Koyama, Y. Esumi, S.-I. Nishimura, K. Hatano, and D. Terunuma, *Tetrahedron Lett.*, 2003, **44**, 3617.
2. M. M. Ponpipom, R. L. Bugianesi, and T. Y. Shen, *Tetrahedron Lett.*, **1978**, 1717; J. Arnarp and J. Lönngren, *J. Chem. Soc., Perkin Trans. I*, **1981**, 2070; T. Ogawa and S. Nakabayashi, *Carbohydr. Res.*, 1981, **97**, 81; R. U. Lemieux, S. Z. Abbas, M. H. Burzinska, and R. M. Ratcliffe, *Can. J. Chem.*, 1982, **60**, 63; R. R. Schmidt, *Liebigs Ann. Chem.*, **1984**, 1826; A. Moranduba and A. Veyrieres,

- Carbohydr. Res.*, 1986, **151**, 105; S. Nilsson, H. Lönn, and T. Norberg, *J. Carbohydr. Chem.*, 1991, **10**, 1023; R. K. Jain, C. F. Piskorz, and K. L. Matta, *Carbohydr. Res.*, 1993, **243**, 385.
3. E. Kaji, F. W. Lichtenthaler, Y. Osa, and S. Zen, *Bull. Chem. Soc. Jpn.*, 1995, **68**, 1172.
 4. S.-I. Nishimura, K. Matsuoka, T. Furuike, S. Ishii, K. Kurita, and K. Nishimura, *Macromolecules*, 1991, **24**, 4236; T. Yoshino, K. Sato, F. Wanme, I. Takai, and Y. Ishido, *Glycoconjugate J.*, 1992, **9**, 287.
 5. S. Nakabayashi, C. D. Warren, R. W. Jeanloz, *Carbohydr. Res.*, 1986, **150**, C7.
 6. The Sigma Chem. Corp. catalogue 2004 / 2005 offers 100 mg of LacNAc for ¥ 87,300-.
 7. R. U. Lemieux, and R. M. Ratcliffe, *Can. J. Chem.*, 1979, **57**, 1244.
 8. E. Kaji and F. W. Lichtenthaler, *J. Carbohydr. Chem.*, 1995, **14**, 791.
 9. F. W. Lichtenthaler, E. Kaji, and S. Weprek, *J. Org. Chem.*, 1985, **50**, 3505.
 10. F. W. Lichtenthaler and P. Jarglis, *Angew. Chem., Int. Ed. Engl.*, 1982, **21**, 625; F. W. Lichtenthaler, P. Jarglis, and W. Hempe, *Liebigs Ann. Chem.*, **1983**, 1959.
 11. F. W. Lichtenthaler and E. Kaji, *Liebigs Ann. Chem.*, **1985**, 1659.
 12. S. Hakomori, *Adv. Cancer Res.*, 1989, **52**, 257.
 13. J. Herscovici, M.-J. Ergon, and K. Antonakis, *J. Chem. Soc., Perkin Trans. I*, **1988**, 1219.
 14. A. Giannis and K. Sandhoff, *Angew. Chem., Int. Ed. Engl.*, 1989, **28**, 218.
 15. K. Matsuoka, S.-I. Nishimura, and Y. C. Lee, *Bull. Chem. Soc. Jpn.*, 1995, **68**, 1715; S.-I. Shoda, R. Izumi, M. Suenaga, K. Saito, and M. Fujita, *Chem. Lett.*, **2002**, 150.