

HETEROCYCLES, Vol. 89, No. 4, 2014, pp. 869 - 962. © 2014 The Japan Institute of Heterocyclic Chemistry  
Received, 8th September, 2013, Accepted, 2nd December, 2013, Published online, 20th December, 2013  
DOI: 10.3987/REV-13-781

## RECENT PROGRESS IN METAL ASSISTED MULTICOMPONENT SYNTHESSES OF HETEROCYCLES

Pradip Kumar Maji,<sup>\*a</sup> Rafique Ul Islam,<sup>\*b</sup> and Sujit Kumar Bera<sup>a</sup>

<sup>a</sup> Department of Chemistry, Bidhan Chandra College, Asansol, Burdwan, 713304, West Bengal, India

<sup>b</sup> Department of Applied Chemistry, Birla Institute of Technology, Mesra, Ranchi, 835215, Jharkhand, India

\*Corresponding author: E-mail: pradip\_maji@yahoo.co.in; Tel: +91-3412283020; Fax: +91-3412283058

**Abstract**—This review highlights some remarkable achievements made recently in the application of metal-catalyzed processes to the design of multicomponent syntheses of heterocycles. The domino MCRs that are purely based upon metal catalysis opens a vast field for the discovery of new sequences in heterocyclic synthesis. Many of these methods have proven to be the most powerful and are currently applied in target- or diversity-oriented syntheses. These reactions can dramatically reduce the generation of chemical wastes, costs of starting materials, and the use of energy as well as manpower. Moreover, the reaction period can be substantially shortened. This review article aims to report the recent developments devoted to this important area, focusing on the metal catalysis in multicomponent synthesis of heterocycles.

### CONTENTS

#### 1. Introduction

#### 2. Construction of five-membered heterocycles

##### 2.1 Heterocycles containing one heteroatom

##### 2.1.1 Synthesis of pyrrole, pyrroline and pyrrolidine derivatives

##### 2.1.2 Synthesis of indoles, isoindoles, indolines and pyrroloindoles

##### 2.1.3 Synthesis of indolizines and oxindoles

##### 2.1.4 Synthesis of furans and furanones

##### 2.1.5 Synthesis of benzofurans and bezofuranones

- 2.1.6 Synthesis of furobenzopyrane
- 2.2 Heterocycles containing two heteroatoms
  - 2.2.1 Synthesis of pyrazole derivatives
  - 2.2.2 Synthesis of imidazole and imidazopyridine derivatives
  - 2.2.3 Synthesis of oxazole, isoxazole and oxazolidinone derivatives
  - 2.2.4 Synthesis of dioxolanes and oxasilacycles
- 2.3 Heterocycles containing three heteroatoms
  - 2.3.1 Synthesis of triazoles
- 2.4 Heterocycles containing four heteroatoms
  - 2.4.1 Synthesis of tetrazoles
- 3. Construction of six-membered heterocycles
  - 3.1 Heterocycles containing one heteroatom
    - 3.1.1 Synthesis of pyridine and dihydropyridone derivatives
    - 3.1.2 Synthesis of tetrahydroquinoline, quinoline and isoquinoline derivatives
    - 3.1.3 Synthesis of quinolone and isoquinolone derivatives
    - 3.1.4 Synthesis of pyran and lactone derivatives
  - 3.2 Heterocycles containing two heteroatoms
    - 3.2.1 Synthesis of pyrimidine and dihydropyrimidone derivatives
    - 3.2.2 Synthesis of quinazolinone, quinoxaline and promazine derivatives
  - 3.3 Heterocycles containing three heteroatoms
- 4. Construction of seven-membered heterocycles
- 5. Miscellaneous
- 6. Conclusion
- 7. Acknowledgement
- 8. References and Notes

## 1. INTRODUCTION

There are many heterocyclic frameworks which are widely distributed in nature. Various natural products, many dyestuffs and pigments contains heterocyclic core and they have wide range applications in medicinal field.<sup>1</sup> Heterocycles are versatile building blocks in organic synthesis and by virtue of their multiple reactivity profiles and structures, these can be delicately manipulated to achieve required modification. Thus the syntheses of these heterocycles due to their fundamental importance in living system have attracted organic chemists towards the development of novel and more efficient synthetic strategies. Many of these strategies involve the formation of either carbon-carbon or carbon-heteroatom

bonds from their corresponding acyclic precursors. Most of the classical methodology utilizes comparatively harsh reaction conditions and suffer various disadvantages such as use of expensive catalyst, elevated temperature, longer reaction time, multistep transformations, poor yield of the final product, tedious work-up etc. Considering the fundamental issues of chemo-, regio-, stereoselectivity, as well as economical and ecological aspects of green and sustainable chemistry,<sup>2</sup> a novel, concise and efficient synthetic routes has become a demanding challenge among the synthetic community.<sup>3,4</sup> Among several newly developed methodologies, the productive concept of diversity-oriented<sup>5</sup> multicomponent reactions (MCRs) have gained a considerable attention among the organic chemists during the last decade. A multicomponent reaction (MCRs) is ideally a synthesis which starts from readily accessible components, proceeds fast and safe, environmentally benign operation, performing multiple steps in a single operation. In this synthesis, several bonds are formed in one sequence without isolating the intermediates in quantitative yield, and can directly build complicated molecules under mild conditions. Many MCRs are well suited too for the construction of various heterocyclic cores. Therefore MCR-based synthesis developed a sustainable use of chemical resources and reduced the amount of waste product by the use and disposal of harsh reactants and reagents as well as minimised the number of steps required for organic transformations.<sup>6</sup> As a consequence, the design of novel MCRs and their exploration as tools in especially heterocyclic chemistry receive growing attention internationally. Novel MCRs are not only applied in combinatorial and medicinal chemistry but also in catalysis and more traditional natural products syntheses. This present brief review is entirely devoted to an updated summary of multicomponent reactions (MCRs) approaches towards the synthesis of heterocycles.

## 2. CONSTRUCTION OF FIVE-MEMBERED HETEROCYCLES

### 2.1 HETEROCYCLES CONTAINING ONE HETEROATOM

#### 2.1.1 SYNTHESIS OF PYRROLE, PYRROLINE AND PYRROLIDINE DERIVATIVES

Pyrrroles represent an important class of heterocycles in organic chemistry which are a structural units in many natural products and pharmaceuticals as well as a key intermediates for the synthesis of a variety of biologically active molecules and functional materials.<sup>7</sup> Most of the conventional methods for the construction of a pyrrole ring are the Hantzsch reaction,<sup>8</sup> the Paal-Knorr synthesis,<sup>9</sup> and various cycloaddition methods.<sup>10</sup> Although a number of metal-catalyzed approaches were also developed for the construction of pyrrole ring<sup>11</sup> still, search for a general and an efficient synthetic strategies from simple and readily available precursors are of great value due to the great importance of the pyrrole core. Multicomponent synthesis of 4-iodopyrroles **1** using copper iodide and a catalytic amount of PdCl<sub>2</sub>(PPh<sub>3</sub>)<sub>2</sub> from the reaction between acyl chlorides, *N*-Boc protected propargylamines and sodium iodide has been reported. The reaction is believed to be proceeded through a

coupling/addition/cyclocondensation sequence. It was subsequently found that these 4-iodopyrroles, upon addition of another alkyne, undergoes an *in situ* Sonogashira coupling to yield 2-substituted 4-alkynyl-*N*-Boc pyrroles **2** (Scheme 1).<sup>12</sup>

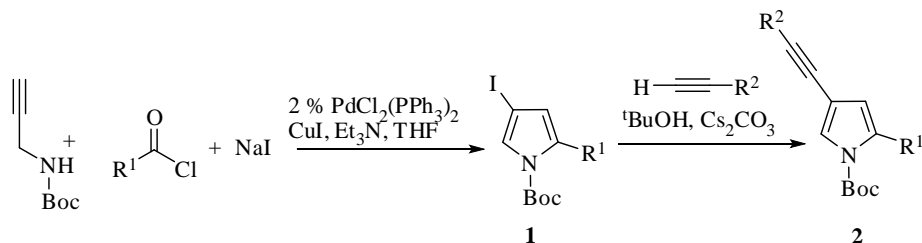

Scheme 1

Multicomponent sequence that leads to pyrrole derivatives from the reaction between phenylacetylene, imines derived from ethyl glyoxylate and dialkylzinc derivatives has also been described (Scheme 2).<sup>13</sup>

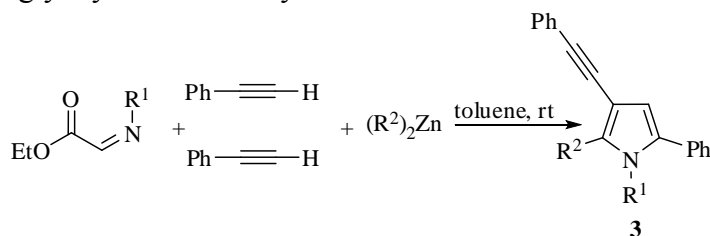

Scheme 2

Reactions between  $\beta$ -ketoesters or symmetrical  $\beta$ -diketones, diacylacetylenes and ammonium acetate in the presence of indium trichloride afforded 3,3'-bipyrrole **4** via a double enaminone formation-Michael addition sequence (Scheme 3).<sup>14</sup>

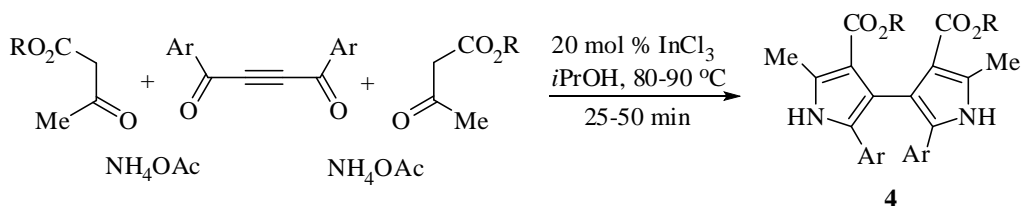

Scheme 3

A one-pot, three component reaction between primary amines,  $\beta$ -ketoesters or  $\beta$ -diketones and propargyl alcohols afforded pyrroles **5** in the presence of the  $[\text{Ru}(\eta^3\text{-}2\text{-C}_3\text{H}_4\text{Me})(\text{CO})\text{-}(\text{dppf})][\text{SbF}_5]$  system, where dppf is 1,10-bis(diphenylphosphanyl)ferrocene, in good to excellent yields (Scheme 4).<sup>15</sup>

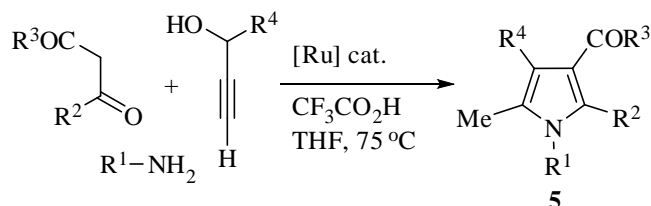

Scheme 4

$\text{PdI}_2/\text{KI}$  has proved to be an efficient catalytic system for the direct synthesis of a variety of carbonylated heterocyclic system starting from suitably functionalized alkynes, by either a cyclocarbonylation or a cyclization-carbonylation reaction sequence. Synthesis of pyrrole-3-carboxylic acid ester derivatives starting from readily available building blocks is achieved by  $\text{PdI}_2$ -catalyzed oxidative heterocyclization-alkoxycarbonylation of *N*-Boc-1-amino-3-yn-2-ols followed by basic treatment.<sup>16</sup> Sonogashira cross-coupling and double cyclization strategy for the formation of hetero dimmers of heterocycles via C-H activation has recently reported by Ohe *et al.*<sup>17</sup> Synthesis of a variety of 2-(2'-furyl)pyrroles **6**, 2-(5'-thienyl) furans and 2-(5'-thienyl) pyrroles **7** under mild condition involves several C-C and C-N bond formation in the presence of Pd and Cu catalyst (Scheme 5).

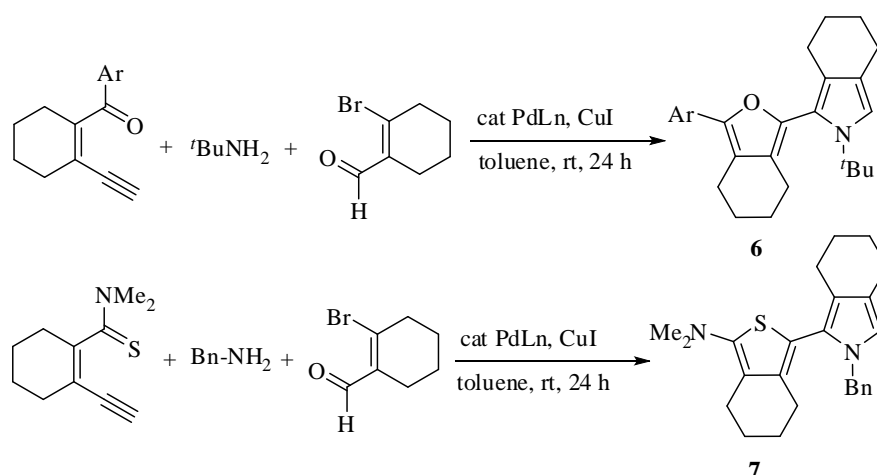

Scheme 5

An efficient one-pot three component reaction of primary amines, dialkyl acetylenedicarboxylates, and nitrostyrene derivatives in the presence of  $\text{FeCl}_3$ , leads to tetrasubstituted polyfunctional pyrroles in high yields which follows a sequence of domino Michael addition/cyclization process.<sup>18</sup> Regioselective synthesis of polysubstituted pyrroles **8** via the copper-catalyzed three component reaction of diazoketones, nitroalkenes, and amines under aerobic conditions which involves an N-H insertion of carbene, a copper-catalyzed oxidative dehydrogenation of amine, and a [3+2] cycloaddition of azomethine ylide has been reported (Scheme 6).<sup>19</sup>

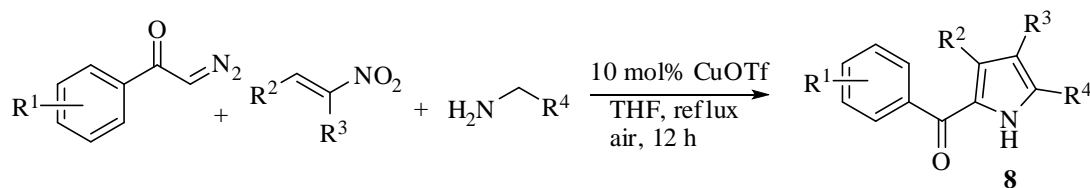

Scheme 6

Pyrrolo[3,2-*d*]pyridazines are a class of interesting and useful *N*-heterocycles with a limited report of synthetic methods. Most of the known pyrrolo[3,2-*d*]pyridazines were synthesized via condensation of pyrrole-2,3-diones with hydrazine. Recently, one-pot multicomponent synthesis of pyrrolo[3,2-*d*]pyridazine derivatives **9** via zirconocene-mediated cyclization of one equivalent of Si-tethered diyne, two equivalents of nitriles, and one equivalent of an azide have reported. Instead of normal azides, if trimethylsilyl azides are used, interestingly the same synthetic procedure affords pyrrole-2,3-diones **10**. Further, these functionalized pyrrole-2,3-diones could be transformed into pyrrole-fused heterocycles (Scheme 7).<sup>20</sup>

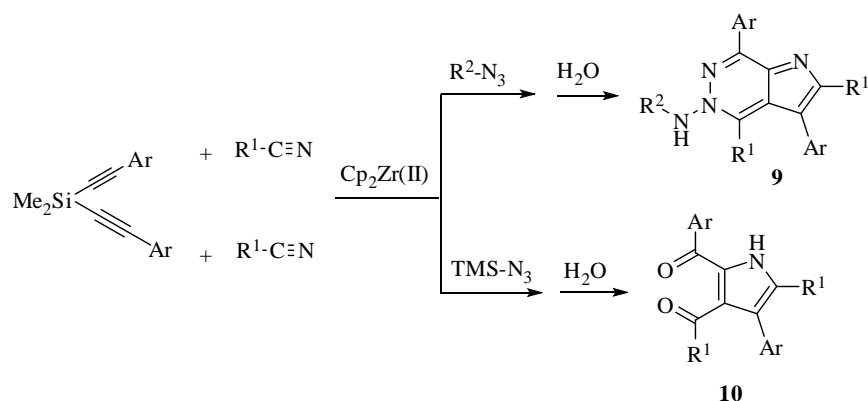

Scheme 7

Rhodium(II)-catalyzed multicomponent reaction of an imine, diazoacetone (DAN) and an activated alkynyl coupling partner, e.g., dimethyl acetylenedicarboxylate (DMAD), for the synthesis of substituted 1,2-diarylpyrroles has been reported.<sup>21</sup> Mechanistically, the diazo compound produces the corresponding metalcarbenoid in the presence of a rhodium(II) salt. The imine then reacts with this electron-deficient metalcarbenoid to generate an azomethine ylide **11**. Finally, this 1,3-dipole undergoes a [3+2] cycloaddition with the activated alkynyl dipolarophiles and subsequent elimination to afford the 1,2-diarylsubstituted pyrrole **12** (Scheme 8).

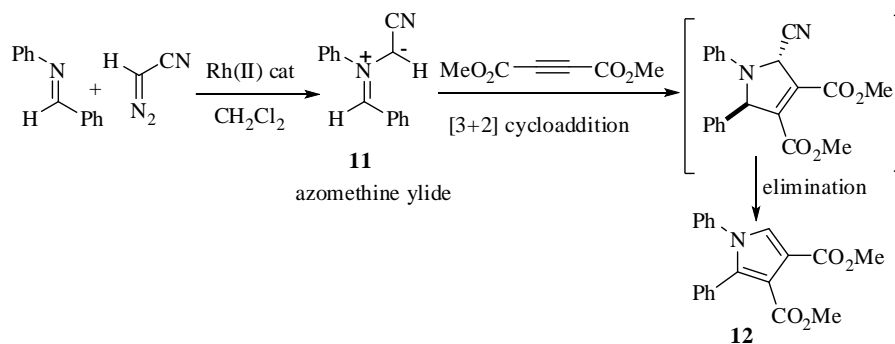

Scheme 8

Three component coupling of 1,3-diketones, aldehydes and amines in the presence of low-valent titanium as a catalyst afforded the pyrrole derivatives **13** (Scheme 9).<sup>22</sup>  $\text{TiCl}_4/\text{Sm}$  gave the best results among different types of low-valent titanium systems such as  $\text{TiCl}_4/\text{Sm}$ ,  $\text{TiCl}_4/\text{Zn}$ ,  $\text{TiCl}_4/\text{Al}$ , or  $\text{TiCl}_4/\text{Mg}$  studied as reagents for this reaction. This protocol highlighted the wide scope of this three component reaction, applicable not only to aromatic aldehydes and aromatic amines bearing either electron-withdrawing or -donating groups, but also to heterocyclic or aliphatic aldehydes and aliphatic amines.

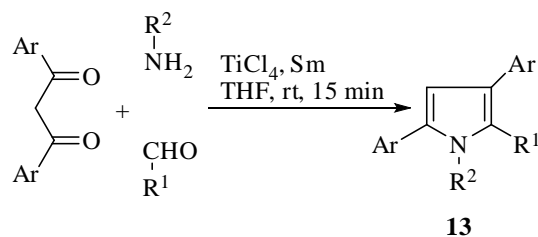

Scheme 9

An  $\text{InCl}_3$ -catalyzed one-pot three component synthesis of 2-pyrrolo-3'-yloxindoles, **14** by a sequential Michael addition followed by Paal-Knorr condensation was achieved (Scheme 10). Multicomponent reaction of 3-phenacylideneoxindole,  $\beta$ -ketoester, and ammonium acetate at refluxing condition in ethanol afforded the products in good yields.<sup>23</sup>

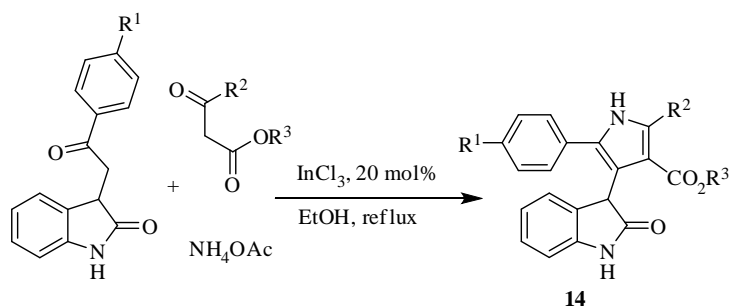

Scheme 10

The catalytic efficacy of  $\text{NiCl}_2 \cdot 6\text{H}_2\text{O}$  has been demonstrated through four component reaction<sup>24</sup> of amine,  $\beta$ -ketoesters or 1,3-dicarbonyl compounds, various aldehydes and nitroalkanes for the synthesis of tetrasubstituted pyrrole **15** (Scheme 11). It is also reported the binding interaction studies of synthesized pyrrole derivatives with different enzymes.

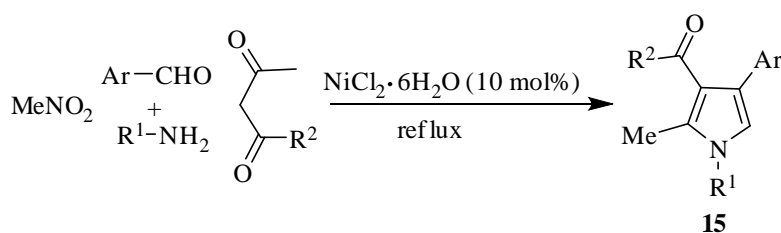

Scheme 11

### 2.1.2 SYNTHESIS OF INDOLES, ISOINDOLES, INDOLINES AND PYRROLOINDOLES

The indole core is renowned as a “privileged motif” because of its presence in many natural products and pharmaceuticals.<sup>25</sup> Much effort has been paid toward the synthesis and functionalization of indoles, and methods for the preparation have been well developed.<sup>26-29</sup> Classical routes for indole formation includes Fischer synthesis<sup>27</sup>, Batcho-Leimgruber synthesis, Gassman synthesis, reductive cyclization<sup>28</sup> and more recently, transition metal catalysis and multicomponent reactions have also been widely applied.<sup>29</sup> Indoles **16** from haloalkenes, amines and *o*-dihaloarenes promoted by palladium-catalyst cascade process has been developed.<sup>30</sup> It is important to note that in this three component reaction, the palladium-catalyst promotes three different and independent reactions: 1) formation of the imine by alkenyl amination 2)  $\alpha$ -arylation of the imine and 3) intramolecular *N*-arylation. The key in the success of this cascade process is the high chemoselectivity of the different cross-coupling events. Thus, the higher reactivity of the bromoalkenes was compared with haloarenes in the oxidative addition to palladium to permit the formation of **17**, instead of the arylation reaction. The dihaloarene is incorporated in the second step only when all the alkenyl halide has been consumed (Scheme 12).

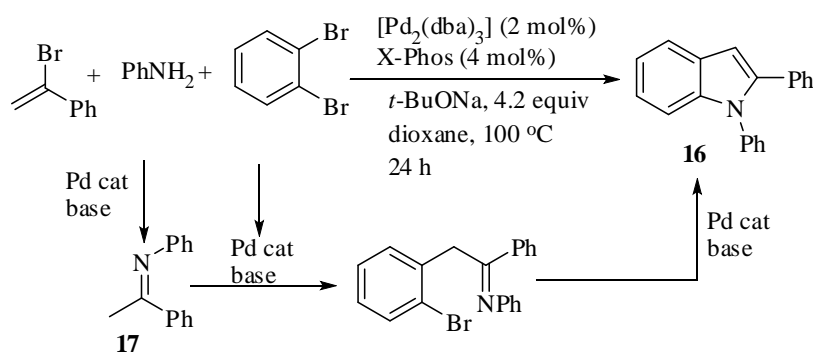

Scheme 12

Literature reveals the wide developed of copper-catalyzed multicomponent reaction of a sulfonyl azide, a terminal alkyne and a nucleophile which involves azide-alkyne cycloaddition reaction generating a ketene amine intermediate through a ring opening rearrangement of triazoles. Recently Wu *et al.*<sup>31</sup> reported the synthesis of a variety of polysubstituted indole derivatives **18** by using copper-catalyzed multicomponent reaction of ethynylaniline, sulfonyl azide and nitroolefines in the presence of a base triethylamine at room temperature involving a ketenimine intermediate through a ring opening rearrangement of triazoles (Scheme 13).

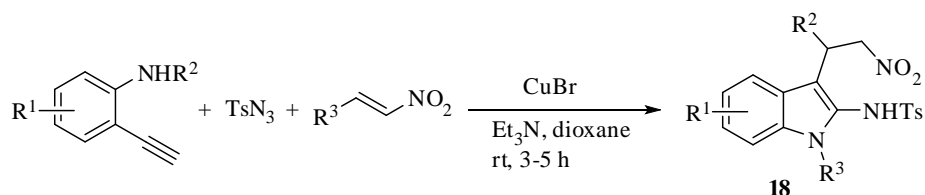

Scheme 13

Synthesis of benzo[*f*]pyrido[1,2-*a*]indole-6,11-dione derivatives **19** via copper(II)-catalyzed three component reactions of acyl bromide, 1,4-naphthoquinone, and pyridine (or isoquinoline) is reported.<sup>32</sup> The reaction proceeds via a  $sp^2C-H$  difunctionalization of naphthoquinone followed by intramolecular cyclization and oxidative aromatization. Use of 1,3-dicarbonyl compounds instead of acyl bromide also afford benzo-fused pyridoindole derivatives in excellent yields (Scheme 14).<sup>33</sup>

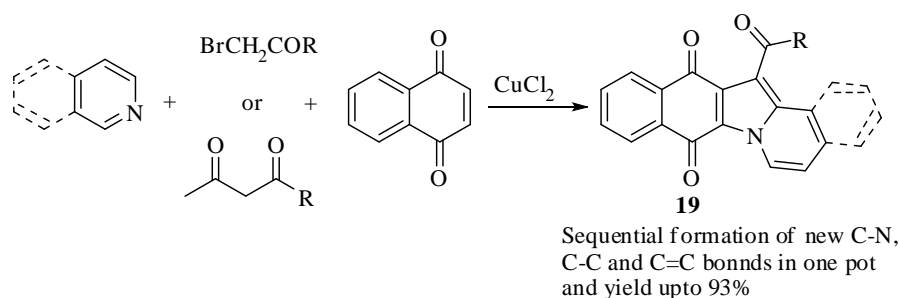

**Scheme 14**

Azaindole nucleus are known to be part of many biologically active compounds, occupying a unique position in medicinal and pharmaceutical chemistry and also serve as building blocks in synthetic chemistry.<sup>34</sup> One-pot multicomponent reaction of an amine, aldehyde and a terminal alkyne for the synthesis of a range of quinoline derivatives linked to azaindole **20** by a Povarov reaction using  $SnCl_2$ , a cheap Lewis acid is described (Scheme 15).<sup>35</sup>

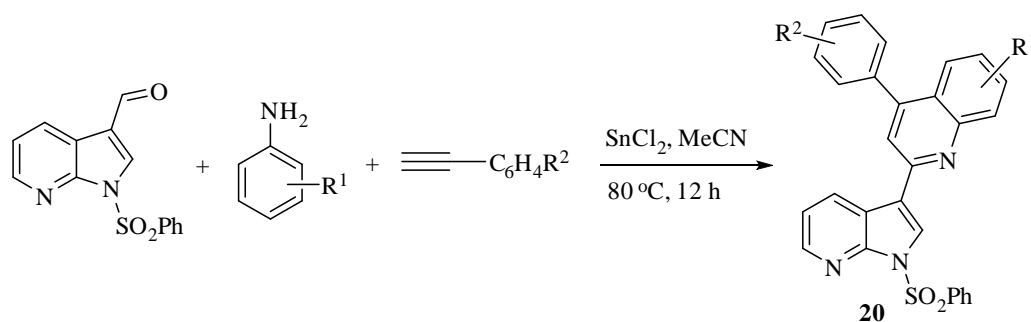

**Scheme 15**

A variety of  $\alpha$ -alkynyl indoles **21** have been synthesized<sup>36</sup> through constructing one  $C_{sp^2}-C_{sp}$  and two  $C_{sp^2}-N$  bond by a novel and an efficient multicomponent reaction of *o*-bromo(dibromovinyl)benzenes, terminal alkynes and arylamines using palladium as catalyst (Scheme 16).

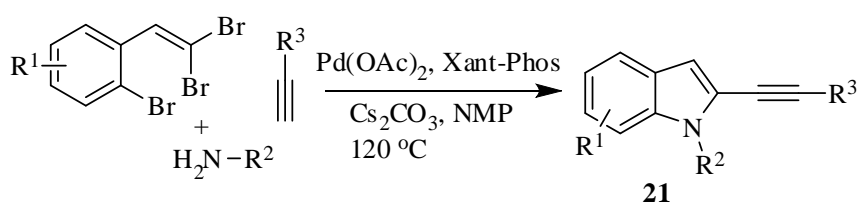

**Scheme 16**

Ketenimine,<sup>37</sup> as an useful intermediate, has attracted much attention due to its easy formation, relative reactivity, and diverse chemistry.<sup>38</sup> The most attractive and sustainable method generating ketenimines could be attributed to the copper-catalyzed azide-alkyne cycloaddition (CuAAC) which is established by Fokin *et al.*<sup>39</sup> Various groups<sup>40</sup> have developed a number of multicomponent reactions by trapping ketenimines generated *in situ* from sulfonyl azides and terminal alkynes via CuAAC reaction. Wang *et al.*<sup>41</sup> has described recently a copper-catalyzed three component cascade reaction of sulfonyl azides, 2-bromophenylacetylenes and amines, which furnished 2-sulfonyliminoindolines **22** in moderate to good yields (Scheme 17).

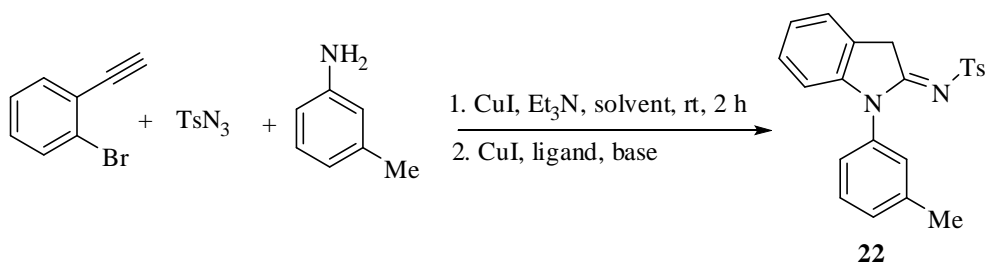

**Scheme 17**

Copper(I)-catalyzed domino reaction provides pyrroloindole **23** and dipyrroloindole derivatives **24** from 4,6-diethynyl-1,3-phenylenediamine or its pyridine congener with paraformaldehyde and secondary amines (Scheme 18).<sup>42</sup> The controlled Mannich-type reaction and cyclization of 4,6-diethynyl-1,3-phenylenediamine or its pyridine congener with paraformaldehyde and secondary amines in the presence of copper catalyst leads to the formation of mono- or bis(aminomethylated) pyrroloindoles **23** (or **24**) in moderate to excellent yields.

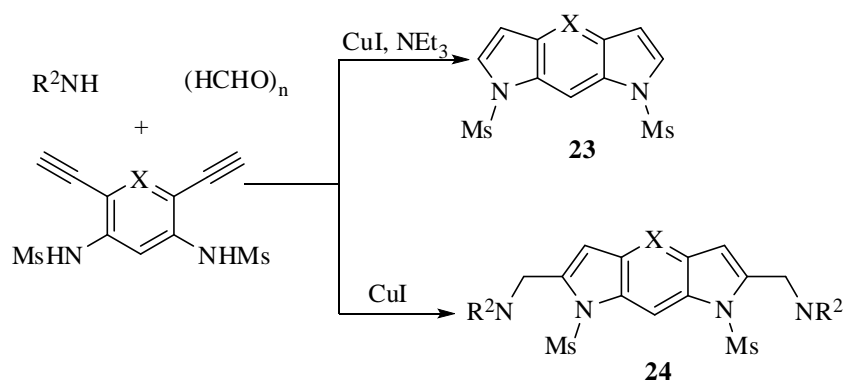

**Scheme 18**

### 2.1.3 SYNTHESIS OF INDOLIZINES AND OXINDOLES

Multicomponent coupling/cycloisomerisation reaction of heteroarylaldehydes, amines, and alkynes under solvent free conditions or in water, in the presence of a gold catalyst, provides rapid access to substituted aminoindolizines **25** (Scheme 19).<sup>43</sup>

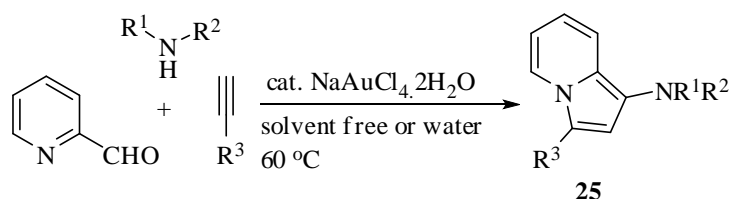

Scheme 19

Biologically important aminoindolizine framework **26** has been synthesized<sup>44</sup> by a facile, atom economic, one-pot multicomponent reaction of pyridine-2-carboxaldehyde or quinoline-2-carboxaldehyde, secondary amine and terminal alkyne using CuCl as catalyst in refluxing condition at PEG. This methodology demands green credentials due to use of non-toxic, inexpensive catalyst and green solvent (Scheme 20).

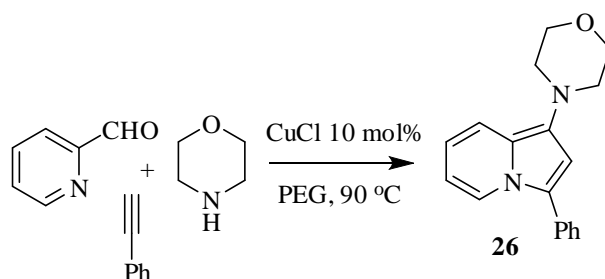

Scheme 20

Oxindoles and its derivatives occupy a key place among the various classes of heterocyclic organic compounds<sup>45</sup> that possess a common basic framework in natural products<sup>46</sup> and pharmaceutically active compounds. Substituted oxindoles have recently attracted attention due to the utility of such structure in the development of biologically active compounds as well as new drugs. A palladium-catalyzed three component synthesis of unsymmetrically substituted 3-(diarylmethylene)indolin-2-ones **27** in good yield starting from aryl bromides, alkyl propiolamides and aryl iodides has been described.<sup>47</sup> The reaction involved a sequence of *N*-arylation, carbopalladation, C-H activation, and carbon-carbon bond formation, and the oxindoles were produced as both *E*- and *Z*-isomers with up to 1:4 (*E/Z*) regioselectivity (Scheme 21).

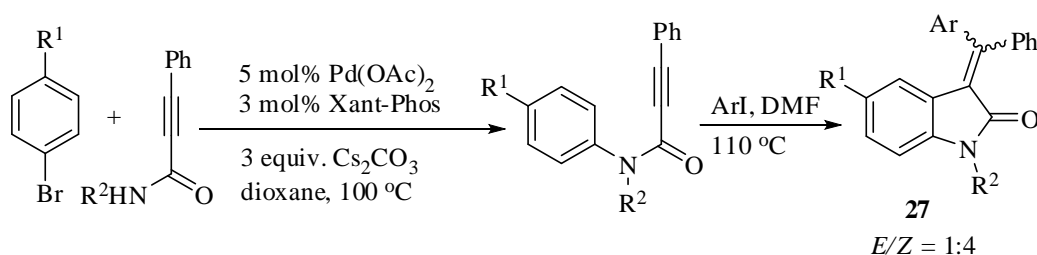

Scheme 21

Multicomponent reaction using  $[\text{Pd}(\text{PPh}_3)_4]$  as a catalyst in the presence of triphenylphosphine from 2-iodoaniline, phenylacetylene and carbon monoxide provides 2-benzylideneindoxyl **28** as a sole product.

This procedure is extended to a variety of indoxyls, mainly obtained as the (*Z*)-isomer (Scheme 22).<sup>48</sup> On the other hand, 2-substituted 4-quinolones **29** are obtained through a one-pot two-step phosphine free multi-catalysis using sequentially  $[\text{PdCl}_2(\text{dppp})]$  and  $\text{HNEt}_2$  as catalysts. An extensive study varying the nature of the palladium catalysts, ligands, bases, additives and solvents has also been reported to elucidate factors controlling the selectivity toward 2-substituted 4-quinolones.

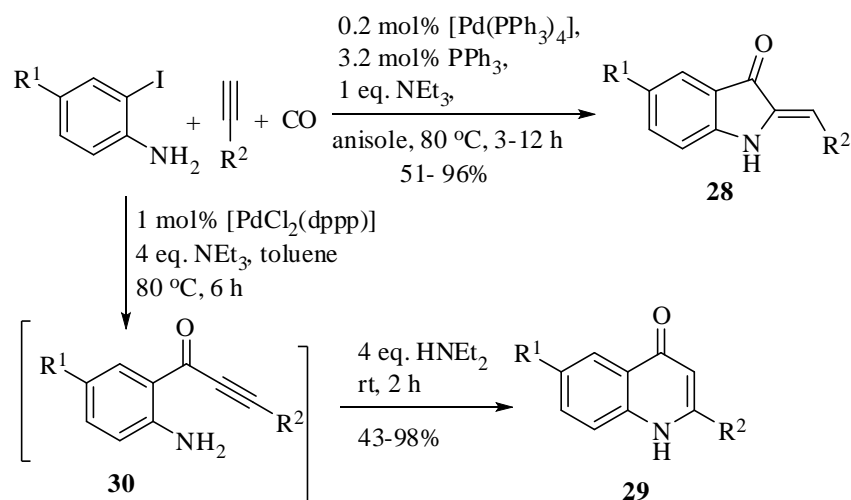

Scheme 22

Transition metal-catalyzed carbonylation reactions, among them mainly palladium-catalyzed amino and alkoxy carbonylation and carbonylative coupling reactions, are well documented and widely used in the area of synthetic chemistry. 2-Bromobenzaldehyde undergoes carbonylative cyclization with aromatic and aliphatic primary amines under carbon monoxide pressure in the presence of a palladium catalyst to give isoindolin-1-ones **31**.<sup>49</sup> Recently, a highly chemoselective intramolecular cycloaminocarbonylation of bifunctional 2-iodobenzyl-bromide towards the similar *N*-substituted 1-isoindolinones is reported.<sup>50</sup> When 2-iodobenzylbromide in place of 2-bromobenzaldehyde is reacted with various primary amines, aniline under atmospheric carbon monoxide pressure in DMF in the presence  $\text{Pd}(0)$  catalysts generated *in situ* from  $\text{Pd}(\text{II})$  acetate catalytic precursor the same 1-isoindolinone derivatives **31** is obtained in good yields. They have also reported<sup>51</sup> a three component palladium-catalyzed cascade hydrazinocarbonylation reaction of iodoarenes, carbon monoxide and various hydrazine derivatives for the formation of tetrahydrophthalazine and phthalamide derivatives (Scheme 23).

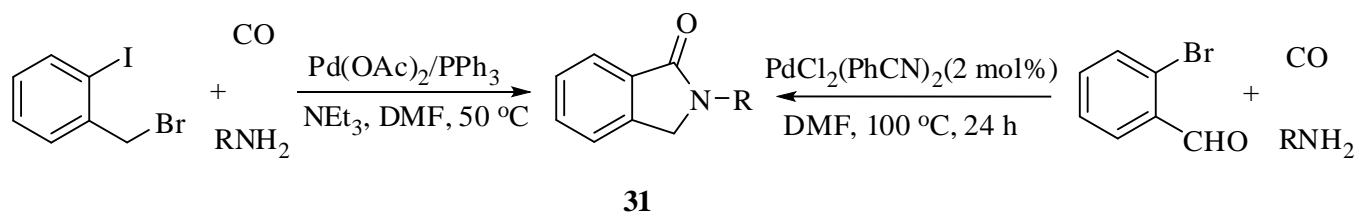

Scheme 23

### 2.1.4 SYNTHESIS OF FURANS AND FURANONES

Concise synthesis of 4,5-substituted  $\gamma$ -butyrolactones **32** from dimethyl itaconate, aromatic aldehyde, and aryl bromides via a multicomponent one-pot reaction in the presence of zinc dust and cobalt bromide is described. As per their report<sup>52</sup> various aldehyde bearing an electron-withdrawing and electron-donating groups provides satisfactory yields except 3-pyridinecarboxaldehyde. Mechanistically this cascade reaction involves the following steps: the formation of zinc reagent, Michael addition, aldol condensation and cyclization to provide the product (Scheme 24).

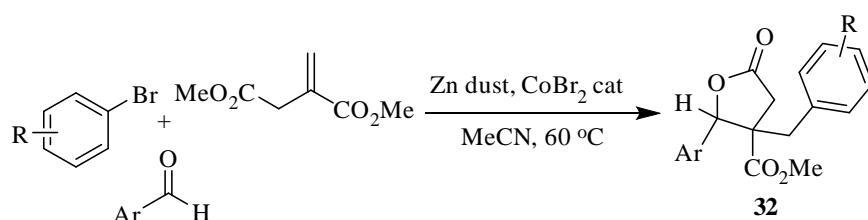

**Scheme 24**

A novel carbon dioxide triggered and copper-catalyzed domino reaction for the efficient synthesis of highly substituted 3(2*H*)-furanones **33** from nitriles and propargylic alcohols has been developed.<sup>53</sup> Carbon dioxide is a prerequisite for achieving the present catalytic transformation, and one of the oxygen atoms of carbon dioxide is inserted into the 3(2*H*)-furanones (Scheme 25). Nitrile acts as the reaction solvent as well as the reactant and copper salts play dual roles of activating both the propargylic alcohols and nitriles. An increase in temperature from room temperature to 70 °C dramatically increased the yield from 8% to 82%.

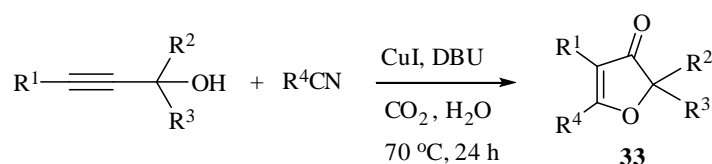

**Scheme 25**

Transition metal-catalyzed  $\text{CO}_2$  activation reactions are widely studied for the formation of new carbon-carbon bonds. Highly regio- and stereoselective methyl-carboxylation of homopropargylic alcohols with  $\text{ZnMe}_2$  and  $\text{CO}_2$  for the synthesis of alkylidene- $\gamma$ -butyrolactones **34** catalyzed by Ni(0) is described (Scheme 26).<sup>54</sup>

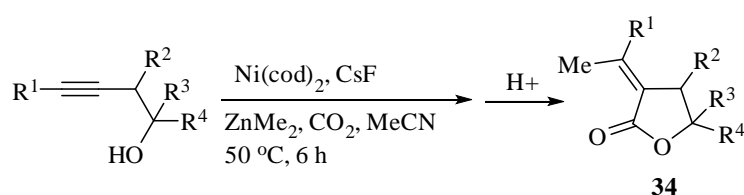

**Scheme 26**

### 2.1.5 SYNTHESIS OF BENZOFURANS AND BENZOFURANONES

A copper-catalyzed multicomponent coupling of salicylaldehydes, amines, and alkynes to dihydrobenzofurans has been reported.<sup>55</sup> However, the alkynes employed are limited to those aliphatic alkynes bearing a heteroatom, such as propargyl alcohols or propargylamines in most cases producing dihydrobenzofuran as a major product. Recently copper-catalyzed three component reaction of salicylaldehydes, amines and alkynes for the construction of benzofuran has been demonstrated.<sup>56</sup> Under this report, aliphatic alkynes bearing a heteroatom, such as propargyl alcohols or propargylamines in most cases produced benzofuran **35** in stead of dihydrobenzofuran from this novel cascade A<sup>3</sup>-coupling-annulation reaction. Similar multifunctionalized benzofuran derivatives have been synthesized from the multicomponent coupling reaction of alkynylsilane, salicylaldehyde and secondary amine using Cu(I)-Cu(II) combined catalysts in moderate to excellent yield. Yield of the products are largely depends upon the ratio of amine used as a component. According to the report, high loading of the catalyst (10 %) also decreases the yield of the products due to coordination of the catalyst with amine, with deactivation of the nucleophilicity of the amine. Mechanistically the reaction proceeds via the formation of copper acetylide from alkynylsilane, and *in situ* generation of iminium intermediate from aldehyde and amine provides propargylamine, which on intramolecular nucleophilic attack by hydroxy group via 5-*exo-dig* mode leads to the benzofuran derivatives **35** (Scheme 27).<sup>57</sup>

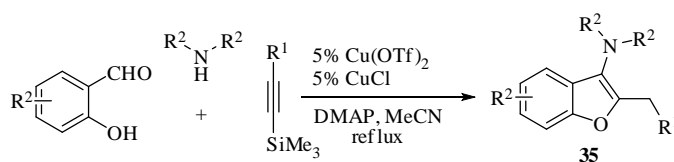

Scheme 27

### 2.1.6 SYNTHESIS OF FUROBENZOPYRANE

Palladium-catalyzed cascade 1,4-addition and cyclization for the synthesis of furochromenes **36** is developed. Suitability of various bases, DIPEA is proved to be the best for this coupling reaction. Compared to other aryl iodides, those having electron-withdrawing functional group favour the faster oxidative addition and afford the corresponding products. Better yields are obtained depending upon the electron-donating nature of R<sup>1</sup> group in arynyl moieties of chromones (Scheme 28).<sup>58</sup>

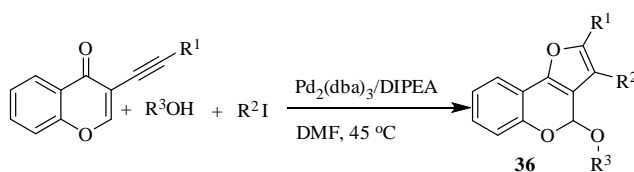

Scheme 28

## 2.2 HETEROCYCLES CONTAINING TWO HETEROATOMS

### 2.2.1 SYNTHESIS OF PYRAZOLE DERIVATIVES

Pyrazoles, five-membered heterocycles with two adjacent nitrogen atoms, display a rich chemistry having various biological and medicinal applications.<sup>59-61</sup> A tandem reaction for the synthesis of pyrazole derivatives has been developed<sup>62</sup> from an acid chloride, terminal alkynes and hydrazine hydrate using palladium and copper catalyst under conventional heating in acetonitrile. Acid chloride is coupled with terminal alkynes to give  $\alpha,\beta$ -unsaturated ynones and converted *in situ* into pyrazoles **37** by the cycloaddition of hydrazines (Scheme 29).

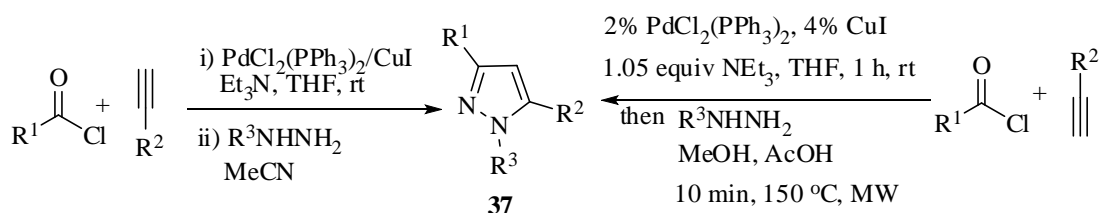

**Scheme 29**

Müller *et al.* have synthesized the pyrazoles **37** in good to excellent yields via one-pot two-step sequential reactions in the presence of palladium catalyst under microwave heating. After formation of alkynones, hydrazines and acetic acid are reacted in the same reaction vessel under microwave irradiation. Best results for the formation of pyrazoles are obtained by heating in the microwave oven at 150 °C for 10 min in the presence of methanol (Scheme 29).<sup>63</sup>

Recently the same group has reported<sup>64</sup> one-pot four-step syntheses of tetrasubstituted pyrazoles based on consecutive sequence of Sonogashira cross-coupling, cyclocondensation, halogenation and Suzuki cross-coupling reaction using the same palladium-based catalyst. Acid chloride reacts with terminal alkyne followed by cyclocondensation with methyl hydrazine which affords the intermediate pyrazole ring. Bromination using NBS and Suzuki cross-coupling with boronic acid finally gives highly fluorescent 1,2,3,4-tetrasubstituted pyrazoles (Scheme 30).

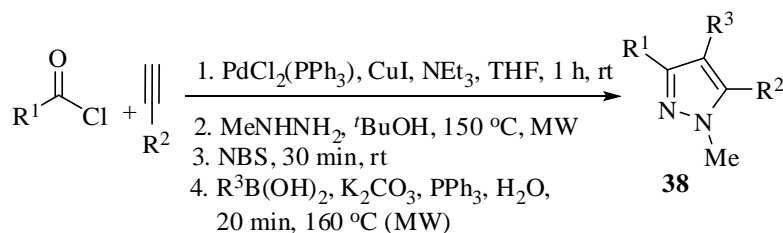

**Scheme 30**

Fully substituted pyrazoles **39** via one-pot three component reaction of aldehydes, phenylhydrazine, and 1,3-dicarbonyl compounds using  $\text{Yb}(\text{PFO})_3$  (ytterbium perfluorooctanonate) as catalyst under solvent free conditions have been developed (Scheme 31).<sup>65</sup>

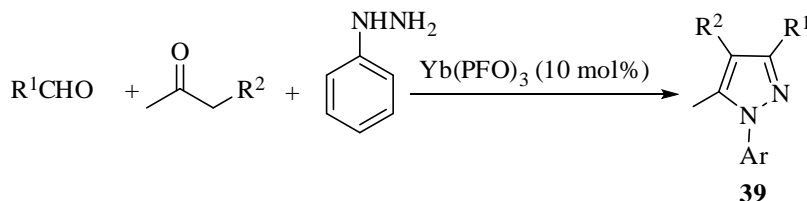

**Scheme 31**

Coupling of a primary amine, an alkyne, and isonitrile followed by treatment with hydrazines yield pyrazoles **40** via titanium-catalyzed three component reaction. Modifications of the catalyst results in good control of regioselectivity for some of the substrates (Scheme 32).<sup>66</sup>

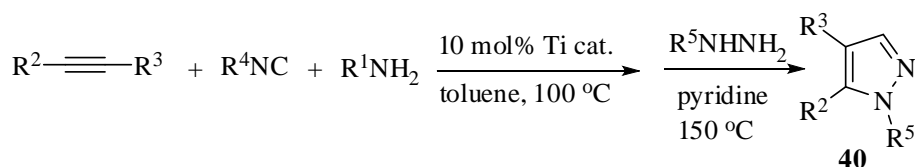

**Scheme 32**

Singh *et al.*<sup>67</sup> developed an efficient, atom economy, simple environmentally benign solvent free microwave-assisted multicomponent synthesis of pyrazole derivatives **41** from phenyl hydrazine, aldehyde and ethyl acetoacetate using  $\text{Sc}(\text{OTf})_3$  as a reusable catalyst (Scheme 33).

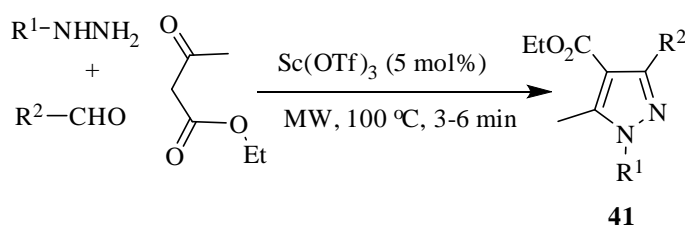

**Scheme 33**

Lee *et al.*<sup>68</sup> has recently reported one-pot three component reaction of a primary amine, 2-bromobenzaldehyde and sodium azide catalyzed by Cu(I) salt by consecutive condensation, C-N and N-N bond formation for the preparation of 2*H*-indazoles **42**. On screening with various metal salts of Fe, Pd, Ni and Co, they have found that only CuI is successful to afford the reaction product. C-N bond formation takes place between the aryl bromide and the azide. The Azide group is then activated by means of coordination of terminal nitrogen atom of the azide to the copper catalyst which attacks the imine adduct of aniline and bromobenzaldehyde resulting the N-N bond formation (Scheme 34).<sup>69</sup>

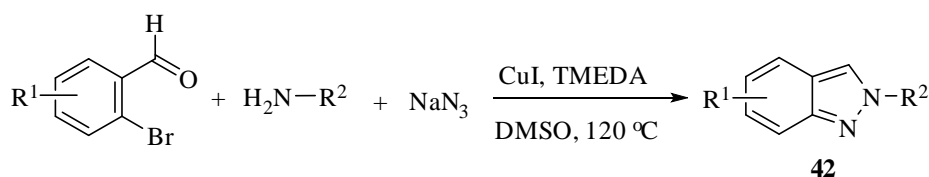

Scheme 34

Transition metal-catalyzed cascade reaction of an alkyne, aldehydes and amines and subsequent nucleophilic cyclization onto an alkyne moiety affords various heterocyclic systems. Gold-catalyzed annulation for the direct and regioselective synthesis of polysubstituted dihydropyrazoles **43** from an alkyne, hydrazines and carbonyl compounds is recently reported by Ohno *et al.* (Scheme 35).<sup>70</sup>

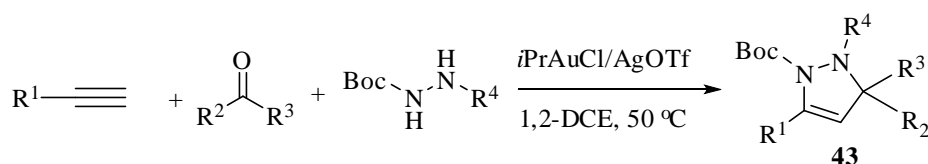

Scheme 35

Four component coupling reaction in the presence of palladium catalyst from a wide range of halides, terminal alkynes, molybdenum hexacarbonyl and hydrazine has been described for the construction of highly substituted pyrazole derivatives **44** and **45** as shown in the Scheme 36.<sup>71</sup> It is interesting to note that Mo(CO)<sub>6</sub> has been used to overcome the limitation of using toxic CO.

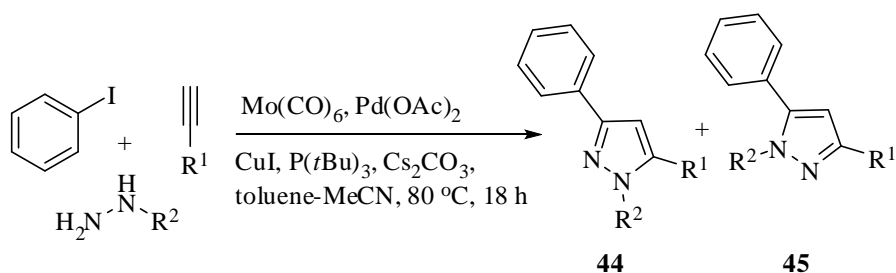

Scheme 36

An efficient, novel and green multicomponent approach is described<sup>72</sup> for the synthesis of fully substituted pyrazole **46a** from the mixture of aldehyde, arylhydrazine and ethylacetoacetate in the presence of Zn(OTf)<sub>2</sub> heated under solvent free condition. It is also described the synthesis of highly substituted bispyrazoles **46b** where 1,4- or 1,3-dialdehyde is used instead of a monoaldehyde (Scheme 37).

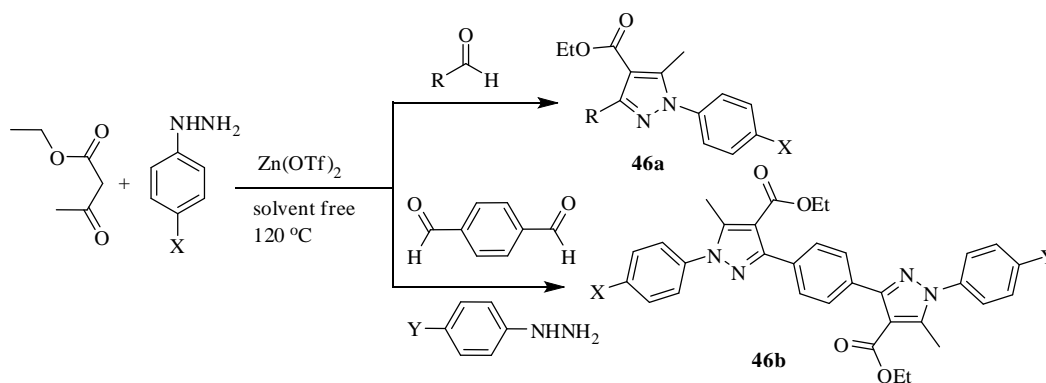

Scheme 37

Wang *et al.* reported<sup>73</sup> an one-pot copper-catalyzed synthesis of 5-sulfonamidopyrazoles **47** from three component reaction of terminal alkynes, sulfonyl azides and hydrazones through a Lewis acid-catalyzed electrocyclic reaction and a dehydrogenation (Scheme 38).

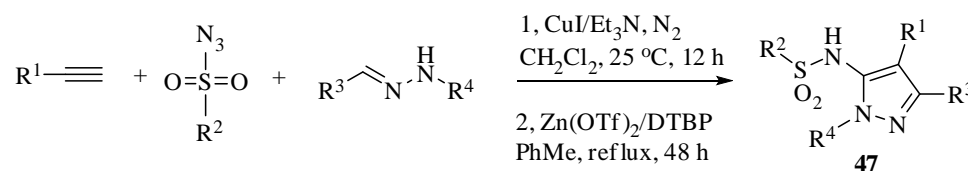

Scheme 38

Synthesis of 2-amino-*H*-pyrazolo[5,1-*a*]isoquinolines **48** via a silver(I)-catalyzed and copper(I) as a co-catalyst three component reaction of *N'*-(2-alkynylbenzylidene)-hydrazide, alkyne, and sulfonyl azide have been described recently (Scheme 39).<sup>74</sup>

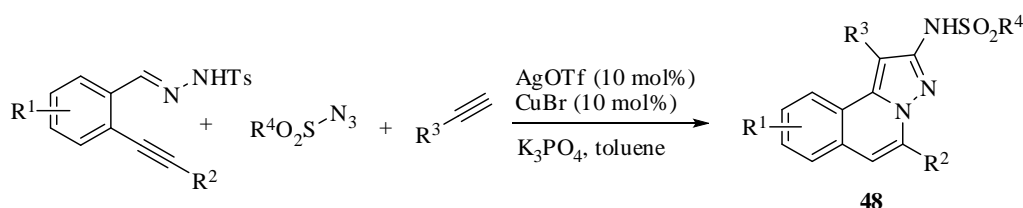

Scheme 39

## 2.2.2 SYNTHESIS OF IMIDAZOLE AND IMIDAZOPYRIDINE DERIVATIVES

Imidazole and its derivatives are an important class of heterocyclic compounds, which are widely used in biology as inhibitors,<sup>75</sup> in medicinal chemistry<sup>76</sup> and also as functionalized materials.<sup>77</sup> Classical methods for the synthesis of imidazoles includes Debus-Radziszewski imidazole synthesis,<sup>78</sup> Weidenhagen imidazole synthesis,<sup>79</sup> and Van Leusen imidazole synthesis.<sup>80</sup> Recently, a number of multicomponent syntheses of imidazoles have also been developed.<sup>81</sup> Nonetheless, development of more efficient and versatile approaches to achieve functionalized imidazoles are still remains very important. The utility of

InCl<sub>3</sub>·3H<sub>2</sub>O protocol for the multicomponent synthesis of 2,4,5-trisubstituted imidazoles **49** has been explored. Highly polar methanol played an important role and beneficial for increasing the yield of the product compared to low polar ethanol, *iso*-propanol and *t*-butanol. Various other solvents like acetonitrile, chloroform, dichloroform and toluene have found to be ineffective for the system (Scheme 40). Initially indium catalyst increases the electrophilicity of carbonyl group of aldehyde to facilitates the formation of diamine which condensed to benzil followed by rearrangement and [1,5] hydrogen shift to furnish the product.<sup>82</sup>

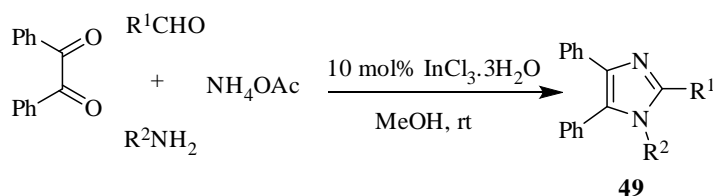

Scheme 40

Li and Pan have recently reported the CuI-PPh<sub>3</sub>-catalyzed multicomponent approach for the synthesis of substituted imidazolines **50**.<sup>83</sup> The scope of the reaction has been investigated to a variety of olefins, including  $\alpha,\beta$ -unsaturated ketones,  $\alpha,\beta$ -unsaturated esters, and simple alkenes (Scheme 41).

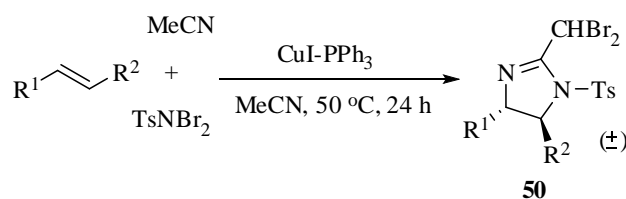

Scheme 41

A palladium-catalyzed multicomponent synthesis of imidazolium carboxylates **51** and imidazolines **52** from a coupling of two imines, acid chloride, and carbon monoxide is described by Arndtsen *et al.* Imidazolines are produced via the initial generation of munchnone intermediates, followed by their cycloaddition with an *in situ* generated protonated imine (Scheme 42).<sup>84</sup>

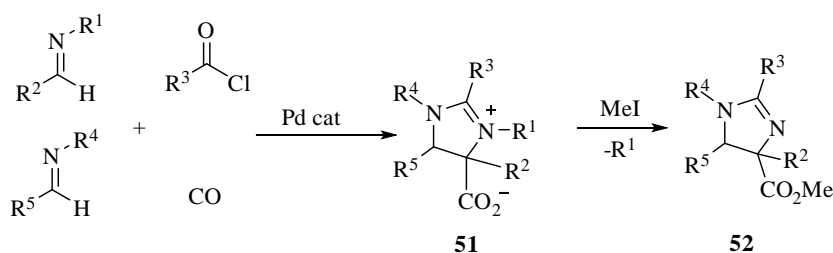

Scheme 42

Imidazoles are important class of small molecules found in many biological active compounds, useful in coordination chemistry, serving as *N*-donor ligands in various metal complexes or as precursors to *N*-heterocyclic carbenes. Palladium-catalyzed multicomponent synthesis of imidazolium carboxylates from imines, acid chlorides and CO through a carbonylation followed by a thermal decarboxylation has been reported.<sup>85</sup> Recently Arndtsen *et al.*<sup>86</sup> has reported that a palladium-catalyzed multicomponent synthesis of 2-imidazoline proceeds via the coupling of imines, acid chlorides and carbon monoxide to form imidazolium carboxylates, followed by a decarboxylation. Although decarboxylation in the presence of CHCl<sub>3</sub> is found to result in a mixture of imidazolium and imidazolinium salts but the addition of benzoic acid selectively generates the *trans*-disubstituted imidazolines in good yield by suppressing aromatization.

Tetrasubstituted imidazoles **53** can be synthesised from propargylamines, sulfonyl azides, and terminal alkynes by generating ketenimines as the intermediate via a copper-catalyzed azide-alkyne cycloaddition and cascade cyclization (Scheme 43).<sup>87</sup>

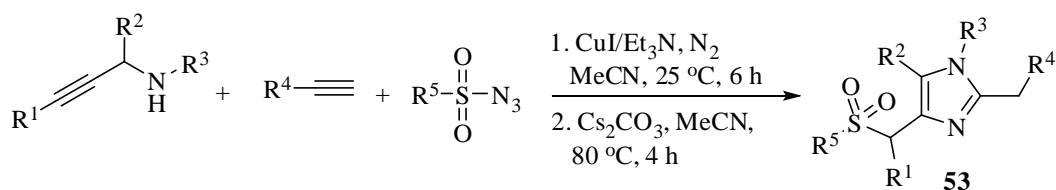

**Scheme 43**

Microwave-assisted one-pot four component coupling of 2-aminopyridine-5-boronic acid pinacol ester, aldehyde and isocyanide through a stepwise sequence (**Scheme 44**) to 3-amino-imidazopyridines **54** is described.<sup>88</sup> Mixture containing MgCl<sub>2</sub> (Ugi Lewis catalyst) and Pd(dppf)Cl<sub>2</sub> (Suzuki catalyst) is failed to produce any desire product under one-pot reaction condition. First Ugi condensation product is formed from 2-aminopyridine-5-boronic acid pinacol ester which then converted into the desired product in the presence of Suzuki catalyst.

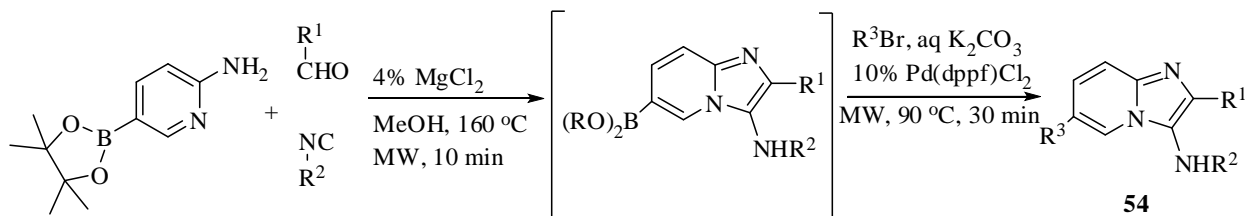

**Scheme 44**

Ugi type Groebke-Blackburn-Bienayme three component reaction<sup>89</sup> of 2-aminopyridine or aminoimidazothiazole, aldehyde and isocyanide under solvent free condition using maghemite

nanoparticles ( $\gamma\text{-Fe}_2\text{O}_3@\text{SiO}_2\text{-OSO}_3\text{H}$ ) leads to the formation of biologically interest aminoimidazopyridine or aminoimidazothiazole derivatives **55** in good yields (Scheme 45).

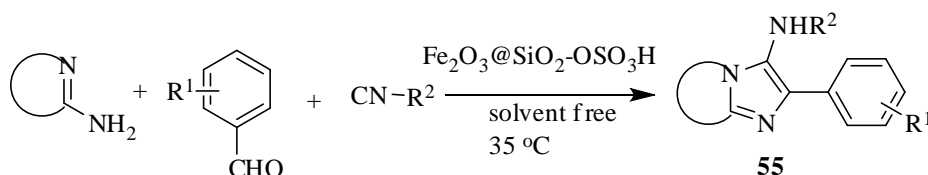

**Scheme 45**

Coupling of 2-aminopyridine, aldehyde and terminal alkyne providing imidazopyridines **56** through one-pot three component reactions in the presence of indium tribromide as catalyst in good yield has been described.<sup>90</sup> *In situ* formation of imine from aldehyde and 2-aminopyridine followed by addition of alkyne which is activated by indium catalyst and deprotonation by triethylamine afforded product **56** (Scheme 46).

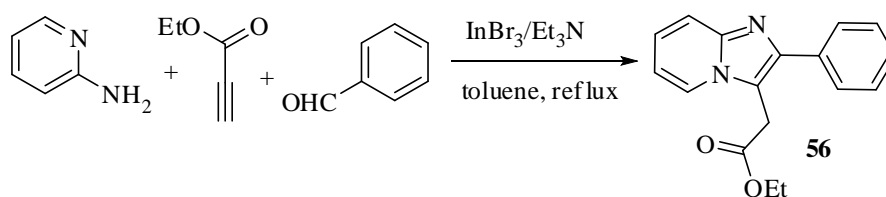

**Scheme 46**

A novel three component reaction of 2-aminopyridines, aldehydes and alkynes in the presence of  $\text{CuSO}_4/\text{TsOH}$  as catalyst (Scheme 47) towards the synthesis of imidazo[1,2-*a*]pyridines **57** has been described.<sup>91</sup> The co-catalyst is a strong Bronsted acid such as TsOH which facilitates the protonation of imine and hence to some extent activates the nucleophilic addition of the alkyne to imine. Another role of the co-catalyst is to prevent the catalyst from the co-ordination with nitrogen atom of 2-aminopyridine. This methodology is ineffective for functional groups on aromatic moieties bearing hydroxyl, dialkylamino, and bromo functionalities. Another reports on the synthesis of imidazo[1,2-*a*]pyridines **57** and the mechanistic study of its formation through one-pot multicomponent cascade reaction using the same components in the presence of copper(I) iodide combined with  $\text{NaHSO}_4\cdot\text{SiO}_2$  as co-catalyst refluxing in toluene has been reported (Scheme 47).<sup>92</sup> Recently a facile and straightforward synthesis of imidazopyridines **57** via one-pot multicomponent reaction of 2-aminopyridine, various aldehydes and terminal alkynes using a magnetic nano- $\text{Fe}_3\text{O}_4$  catalyst with  $\text{KHSO}_4\cdot\text{SiO}_2$  as additive in anhydrous toluene at refluxing condition has been achieved.<sup>93</sup> It is also reported the recovery, reusability and activity of catalyst for new catalytic cycle (Scheme 47).

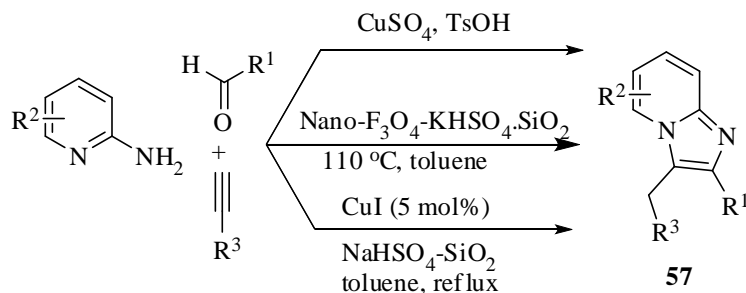

Scheme 47

The multicomponent reaction of aldehyde with amine and alkyne ( $A^3$ -coupling) and its incorporation in cascade processes of tethered cyclization with activation of triple bond in propargylamine affords an access to versatile molecular complex compounds. The coinage metal (Cu, Ag, and Au) salts are efficient enough in catalysis for alkyne C–H activation in alkynylation with  $\sigma$ -activated imine and  $\pi$ -activation of triple bond toward cyclization. A mixed Cu(I)–Cu(II) system *in situ* generated from partial reduction of  $\text{CuSO}_4$  with glucose can be used in ethanol (nonanhydrous) under open air, that efficiently catalyzes the multicomponent reaction of heterocyclic azine and aldehyde with alkyne followed by cycloisomerization to afford *N*-fused imidazoles **58** (Scheme 48).<sup>94</sup>

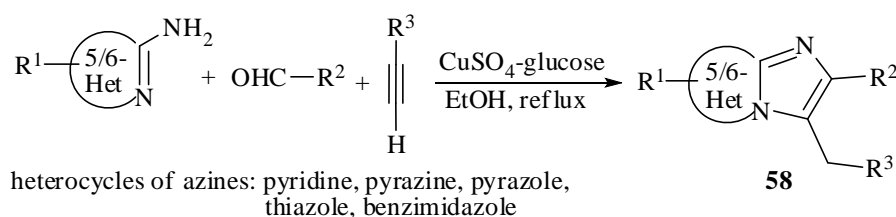

Scheme 48

Utilization of sodium azide as a source of nitrogen for the synthesis of benzimidazoles **59** by the copper-catalyzed, one-pot, three component reaction of 2-haloanilines, aldehydes, and sodium azide have been described very recently (Scheme 49).<sup>95</sup>

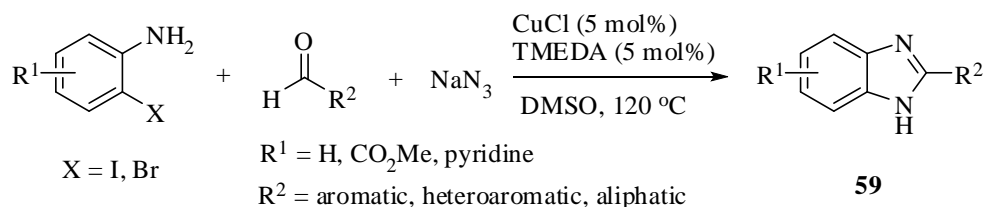

Scheme 49

### 2.2.3 SYNTHESIS OF OXAZOLE, ISOXAZOLE, OXAZOLIDINONE DERIVATIVES

The isoxazoles **60** are obtained in moderate to excellent yields from one-pot coupling-cycloaddition

reaction in the presence of  $\text{PdCl}_2(\text{PPh}_3)_2$  and  $\text{CuI}$  catalytic system. Modified Sonogashira coupling of acid chlorides with terminal alkynes furnished the expected alkynones, which subsequently, on microwave irradiation with hydroximinoyl chlorides in the presence of triethylamine underwent 1,3-dipolar cycloaddition to afford the isoxazoles (Scheme 50).<sup>96</sup>

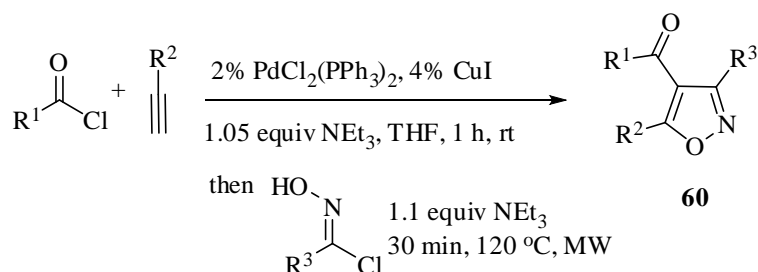

Scheme 50

Multicomponent reactions have the advantages over conventional multistep sequences which includes the savings the costs of reagents and solvents, along with other materials required for purification and isolation. Palladium-catalyzed three component reactions of an aryl halide, isocyanide, and an amino alcohol for the formation of oxazolines **61** and benzoxazoles **62** in excellent yield is reported (Scheme 51).<sup>97</sup>

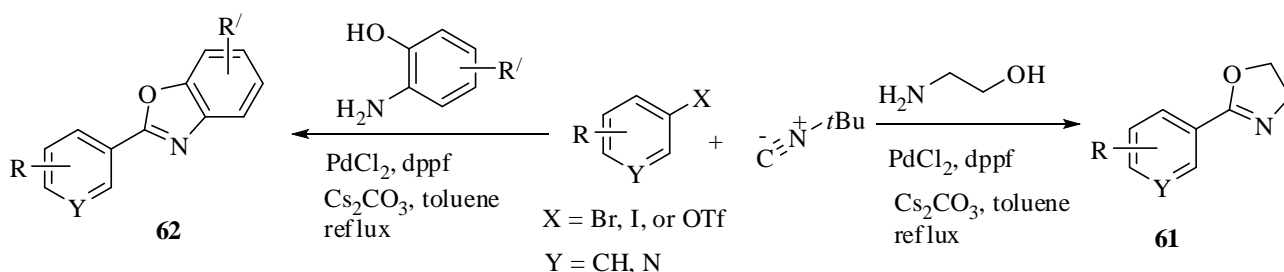

Scheme 51

An efficient one-pot aminocarbonylation and cyclocarbonylation for the synthesis of 2-oxazolidinones **63** has been described.<sup>98</sup> The one-pot method consisted of the reaction of  $\alpha,\alpha$ -disubstituted 2-ynylamines with  $\text{CO}$ ,  $\text{O}_2$ , and morpholine in the presence of catalytic amounts of  $\text{PdI}_2$  in conjunction with  $\text{KI}$  and  $\text{H}_2\text{O}$  ( $\text{PdI}_2/\text{KI}/1/2/\text{H}_2\text{O}$  molar ratio 1:10:100:500:500), in DME as the solvent at  $100^\circ\text{C}$  under 20 atm of a 4:1 mixture of  $\text{CO}/\text{air}$  afforded **63** in excellent yield. The reaction in the presence of secondary amine like piperidine and diethylamine also proceeded smoothly with good yield of oxazolidinones. In the case of an  $\alpha$ -monosubstituted propargylamine, such as benzyl-[1-(1-ethylpropyl)prop-2-ynyl]amine under the same reaction conditions, the initially formed oxazolidinone undergoes a spontaneous double bond shift with the formation of 3*H*-oxazol-2-one derivative **64** in excellent yield (Scheme 52).

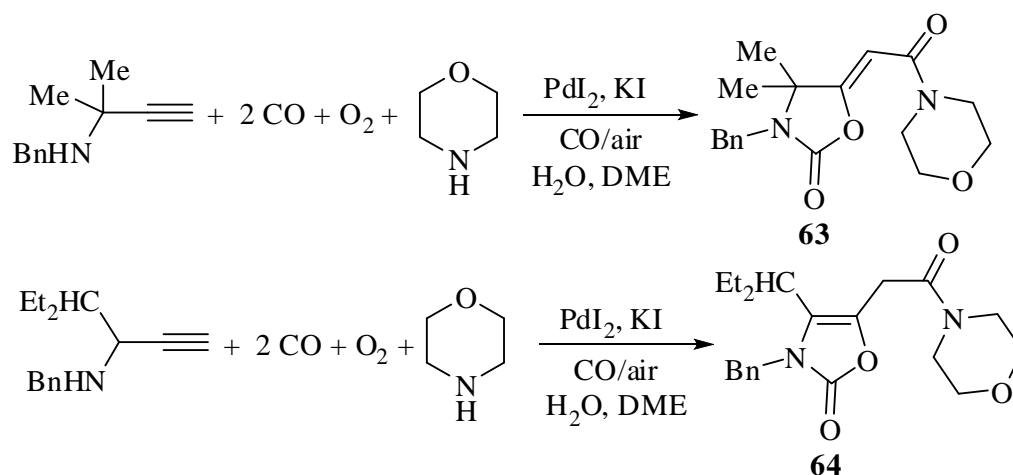

Scheme 52

Imine obtained from condensation of aldehyde and amine in the presence of CuI catalyst reacts with acetylide to form propargylamine derivatives which on cyclization with carbon dioxide furnishes the 3,4,5-trisubstituted 1,3-oxazolidin-2-one **65** quantitatively (Scheme 53).<sup>99</sup>

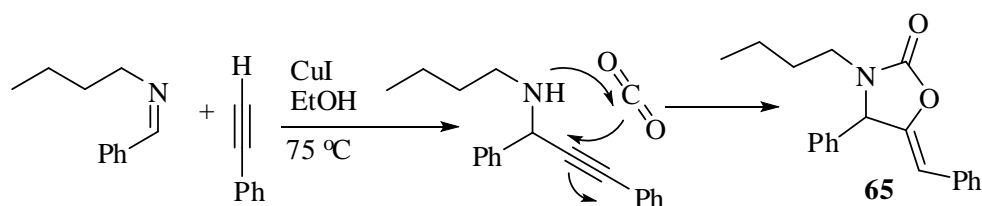

Scheme 53

Inexpensive and reusable ligand free CuO nanoparticles catalyzed three component reaction<sup>100</sup> of 2-iodoaniline, carbon disulfide and amine to synthesize *N*-substituted benzothiazole derivative **66** in good yield has been described recently (Scheme 54).

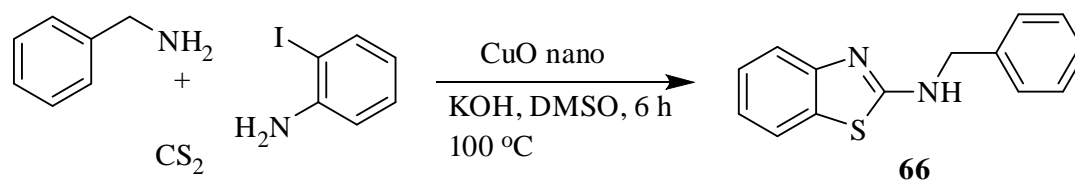

Scheme 54

A domino condensation/S-arylation/heterocyclization process is described<sup>101</sup> for the synthesis of benzothiazoles **67** using Cu(I) catalyst. Condensation of carbon disulfide with thiols in the presence of  $\text{K}_2\text{CO}_3$  generates carbonotrithioate salts *in situ*, which then undergoes coupling with 2-iodoanilines and subsequent intramolecular condensation and elimination under the assistance of CuBr to afford 2-thiosubstituted benzothiazole derivatives (Scheme 55).

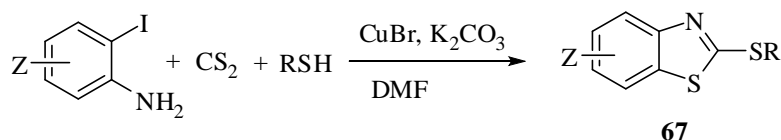
**Scheme 55**

An efficient and convenient multicomponent reaction has been developed by Majumdar *et al.*<sup>102</sup> Different *o*-haloamine compounds, carbon disulfide, and various amines in the presence of copper salt and potassium carbonate as a base undergoes multicomponent reaction and afforded 2-aminothiazole derivatives **68** in good yields. Initially carbon disulfide and amine formed unstable dithiocarbamic acids which readily formed potassium salt of dithiocarbamate. Then Ullmann type coupling between *o*-haloamines and potassium salt of dithiocarbamate followed by elimination of hydrogen sulfide gives the desired products (Scheme 56).

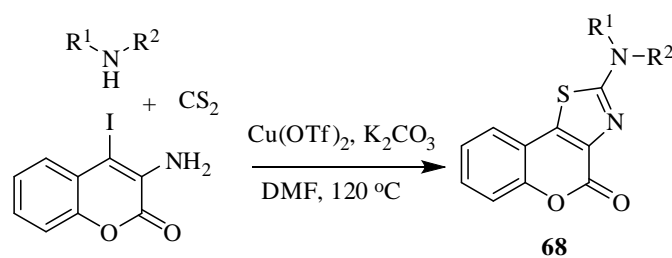
**Scheme 56**

## 2.2.4 SYNTHESIS OF DIOXALANES AND OXASILACYCLES

Chemo- and diastereoselective synthesis of spiro-indolodioxolanes **69** by three component reaction from cyclic diazoamides, one mole of electron-donating and one mole of electron-withdrawing aldehyde in the presence of rhodium acetate as a catalyst at room temperature has been reported.<sup>103</sup> Electron-deficient carbenoid carbon of cyclic rhodium carbenoid which is produced from cyclic diazoamide chemoselectively reacts with electron-donating aldehyde to form carbonyl ylide. Subsequent 1,3-dipolar cycloaddition of the ylide with electron-withdrawing aromatic aldehyde which acts as dipolarophiles, diastereoselectively afforded dioxolanes (Scheme 57).

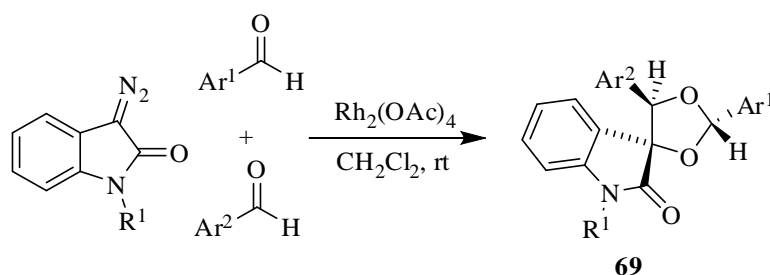
**Scheme 57**

Nickel(0)-catalyzed asymmetric formation of oxasilacyclic derivatives via three component cycloaddition is first reported<sup>104</sup> by Baxter *et al.* Oxasilacycles **70** are synthetically useful and can be prepared by oxidative cyclization of aldehyde, alkyne and dialkylsilane in the presence of Ni(0) catalyst (Scheme 58).

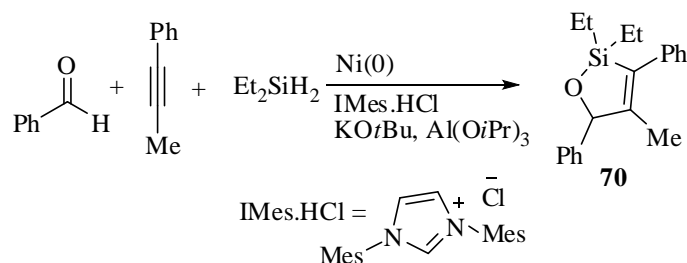

**Scheme 58**

## 2.3 HETEROCYCLES CONTAINING THREE HETEROATOMS

### 2.3.1 SYNTHESIS OF TRIAZOLES

The Copper-catalyzed Huisgen 1,3-dipolar cycloaddition of azides and alkynes for the synthesis of 1,4-disubstituted 1,2,3-triazoles has become very popular among the synthetic chemist since the discovery by the groups of Meldal and Sharpless.<sup>105-108</sup> The superb reliability of the CuAAC reaction has increasingly attracted the attention from a diverse range of the areas of chemistry.<sup>109</sup> As a result, various modifications have been developed to increase efficiency. Among them, use of supported and unsupported metal nanoparticles as an heterogeneous catalyst<sup>109-110</sup> and use of green and ecofriendly conditions are well investigated.<sup>111</sup> One of the important modification is the multicomponent reaction<sup>112</sup> in which organic azides are generated *in situ* from azide precursor, sodium azide and an alkyne by minimising the hazardness from the isolation and handling of azides and also by avoiding one additional step. Reports on the copper-catalyzed multicomponent synthesis of triazoles from organic halides in water, using heterogeneous catalysts, have described in the literature.<sup>113</sup> A chemo- and regioselective one-pot, four component coupling of alkynes with sodium azide has been developed for an elegant modular synthesis of fully substituted 1,2,3-triazoles **71** (Scheme 59).<sup>114</sup> This protocol is expected to find extensive applications as it allows for the use of alkyl- and aryl-substituted alkynes.

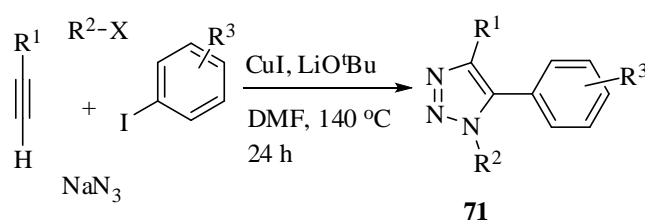

**Scheme 59**

Copper(I)-catalyzed three component cycloaddition reaction of alkynes with sodium azide and formaldehyde to furnish 2-hydroxymethyl-2*H*-1,2,3-triazoles **72** which are versatile synthetic precursors that allow an easy access to a wide variety of triazole derivatives, is reported by Fokin *et al.* (Scheme 60).<sup>115</sup>

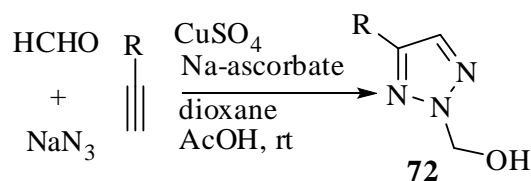

**Scheme 60**

Copper triflate has also been used as a catalyst for both azidation of benzylic acetates and subsequent click reaction in one-pot (Scheme 61).<sup>116</sup>

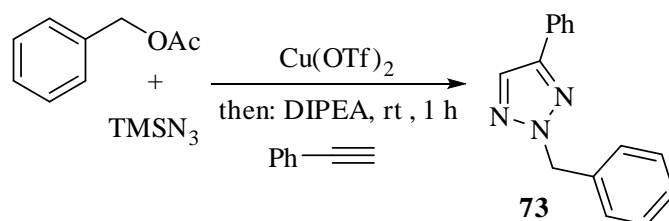

**Scheme 61**

Aliphatic or aromatic primary amines in conjunction with TfN<sub>3</sub> and copper sulfate as catalyst has been used in one-step and sequential one-step procedures<sup>117</sup> for diazo transfer and azide alkyne cycloaddition reaction for the synthesis of triazoles derivatives **74** (Scheme 62).

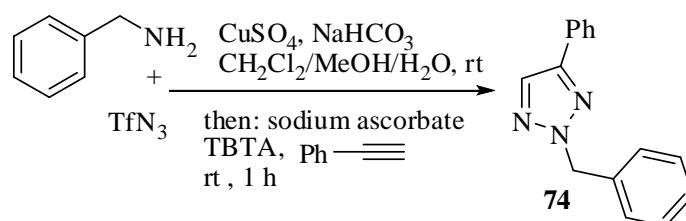

**Scheme 62**

Recently a practical and efficient one-pot diazotization-azidation procedure for the synthesis of 1,4-substituted triazoles **75** utilizing *t*-BuONO and TMSN<sub>3</sub> with amines have developed.<sup>118</sup> Microwave irradiation is found to be significantly enhanced the rate of the formation of the products **75**.<sup>119</sup> This methodology smoothly proceeded with electron-deficient anilines and aromatic as well as aliphatic alkynes bearing electron-rich and electron-deficient functionalities (Scheme 63).

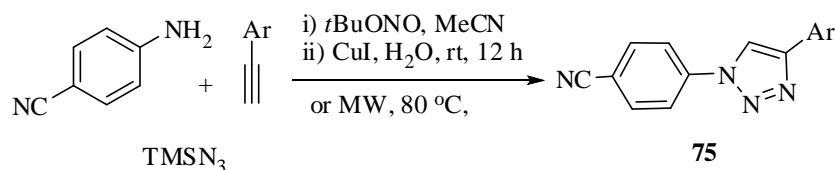

Scheme 63

Multicomponent click reaction of epoxide, sodium azide and alkyne for the preparation of  $\beta$ -hydroxytriazole derivatives **76** has been reported (Scheme 64).<sup>120</sup>

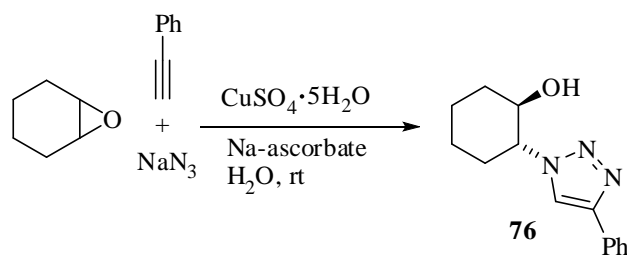

Scheme 64

Copper nanoparticles on various support have been found to effectively catalyze the click reaction affording 1,2,3-triazoles in excellent yield with minimum catalyst loadings.<sup>121</sup> Recently, Yus *et al.* reported<sup>122</sup> the use of copper nanoparticles which can catalyze the multicomponent synthesis of triazoles **77** and **78** from epoxides. A wide range of  $\beta$ -hydroxytriazoles have been synthesized from epoxides, sodium azide, and terminal alkynes with Cu-NPs supported on activated carbon as an inexpensive, safe catalyst and under green solvent as water (Scheme 65).

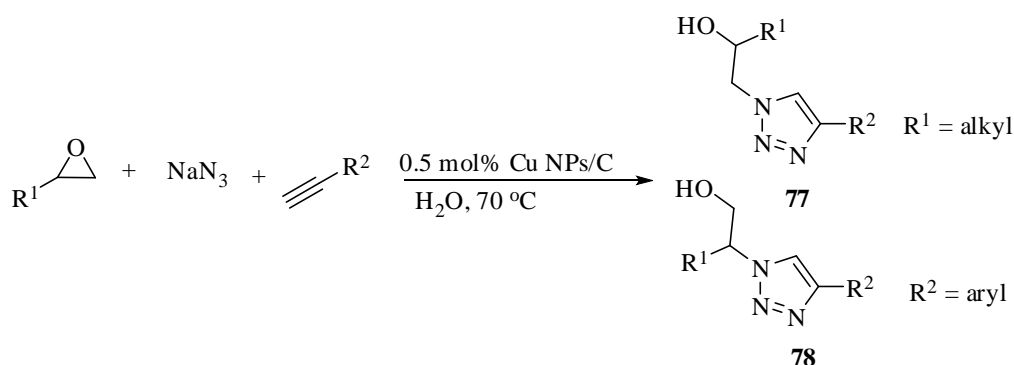

Scheme 65

Phthalazine derivatives, constituting a bridgehead hydrazine, have received considerable attention in the literature as a consequence of their role as pharmacophores and their exciting biological properties.<sup>123a,b</sup> The recent protocols directed toward designing structural motifs containing the phthalazine ring fragment with 1,2,3-triazole moiety, employed an one-pot four component condensation strategy from the reaction of aromatic propargyloxy aldehydes, azides, dimedone/1,3-cyclohexanedione, and phthalhydrazide in high yield and excellent atom economy (Scheme 66).<sup>123c</sup>

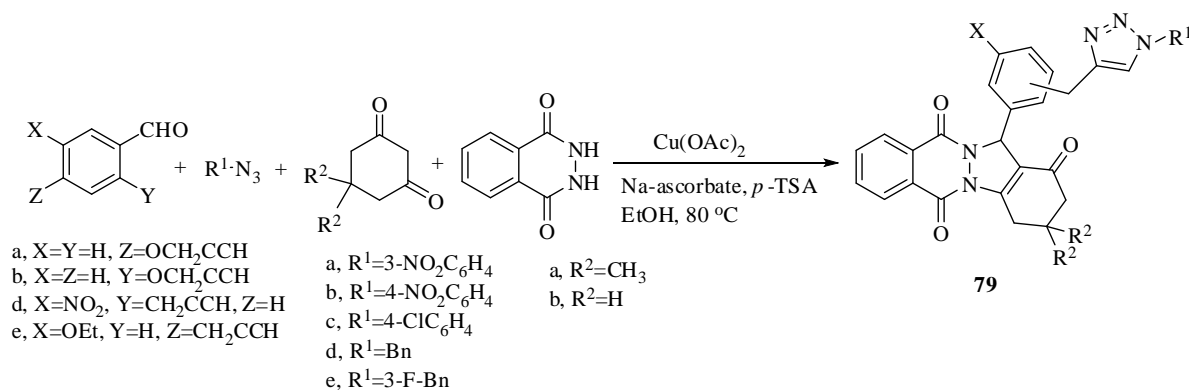

Scheme 66

Coupling of secondary alcohols, alkynes and trimethylsilyl azide affording disubstituted triazoles has been reported. Under this multicomponent click reaction copper catalyst facilitates nucleophilic substitution of alcohols with TMSN<sub>3</sub> to form azides and also activates alkynes resulting 1,3-dipolar cycloaddition (Scheme 67).<sup>124</sup>

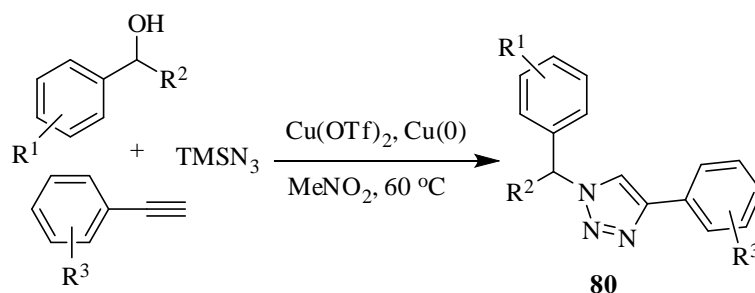

Scheme 67

CuAAC “click and activate” strategy presents a powerful approach in diversity-oriented, multiple component condensation sequences that led to a trisubstituted triazolopyridazinone **81** from 2-substituted 4,5-dihalopyridazinones, an azide and a terminal alkyne.<sup>125</sup> The regioselective triazole formation not only stitches together an alkyne and an azide but also switches the reactivity of the neighboring group, triggering the facile *in situ* introduction of a nucleophile to it. The formation of the triazole should switch the reactivity of the 4-(chloro) position from a “neutral” or “deactivated” to an “activated” state toward nucleophilic attack due to the subtle electronic effect of triazole (Scheme 68).

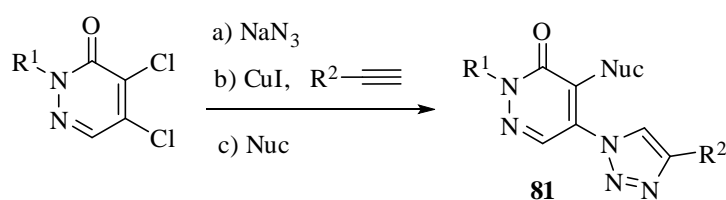

Scheme 68

Usually phenol and aromatic aldehyde is ineffective for this click reaction. A multicomponent, one-pot approach for the synthesis of  $\alpha$ -alkoxytriazoles **82** from aldehydes, alcohols, azides, and alkynes via a four component reaction, proceeding via the formation of hemi-acetal followed by azidation and then click reaction in the presence of Cu(II) salt and metallic copper in acetonitrile has been reported (Scheme 69).<sup>126</sup>

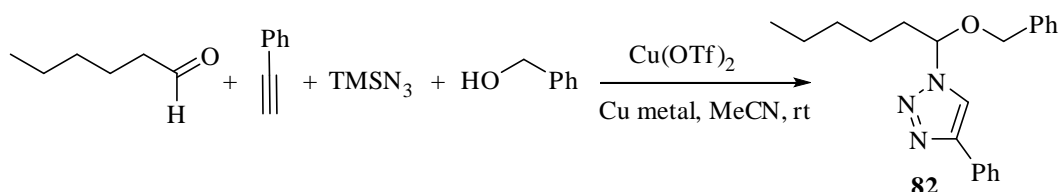

**Scheme 69**

A convenient route for the synthesis of 1,2,3-triazole-linked glycoconjugates **83** and **84** from glucals, trimethylsilyl azide and alkynes via a tandem Ferrier and click reaction has been developed. The reaction is believed to proceed via Ferrier rearrangement followed by [3+2] cycloaddition (Scheme 70).<sup>127</sup>

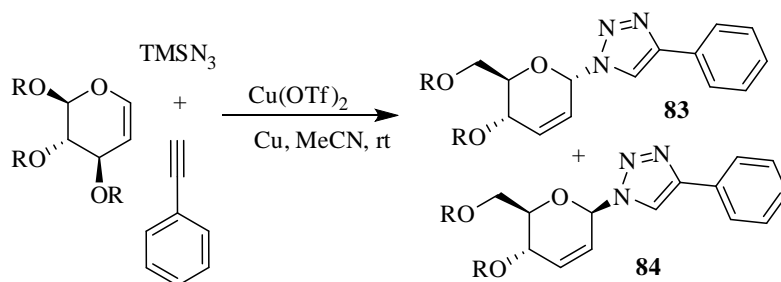

**Scheme 70**

Microwave-assisted multicomponent reaction of substituted benzyl halide, sodium azide and *o*-trimethylsilylphenyl triflate undergoes multicomponent reaction in the presence of cesium fluoride to produce benzotriazole **85** has been described. In this reaction *in situ* aryne is generated from *o*-trimethylsilylphenyl triflate which undergoes click reaction to provide benzotriazole derivative (Scheme 71).<sup>128</sup>

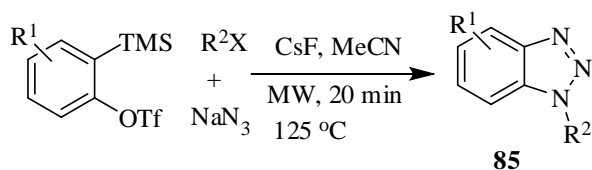

**Scheme 71**

A click reaction for the synthesis of triazole derivative **86** has been developed<sup>129</sup> from benzyl bromide, phenylacetylene and sodium azide using  $\text{CuFe}_2\text{O}_4$  nanocomposite as a catalyst in aqueous medium at 70 °C. The reusability of the catalyst is also examined (Scheme 72). Same component in the presence of  $\text{Cu}_2\text{O}$  catalyist undergoes multicomponent click reaction leading to the formation of 5-alkynyl-1,2,3-triazole derivatives **87** under room temperature<sup>130</sup> in place of triazole derivative **86**. They have also reported the incorporation of deuterium in the 5-position of the 1,2,3-triazole to disclose the mechanistic path for the formation of product **88** by changing the solvent as  $\text{CD}_3\text{OD}$  (Scheme 72).

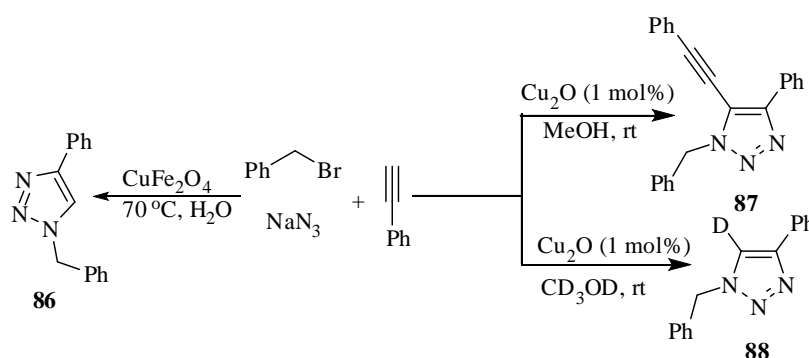

Scheme 72

A practical synthesis of triazole derivative in good yield through one-pot three component<sup>131</sup> reaction of (arylethylene)trimethylsilanes, alkyl bromides and sodium azide using copper sulphate as catalyst by Huisgen cycloaddition reaction is developed. The reaction undergoes *in situ* alkyl azide formation, alkyne deprotection followed by cycloaddition for the formation of 1,4-disubstituted 1,2,3-triazole **89** as major product and 1,5-regioisomeric cycloadduct **90** as minor product (Scheme 73).

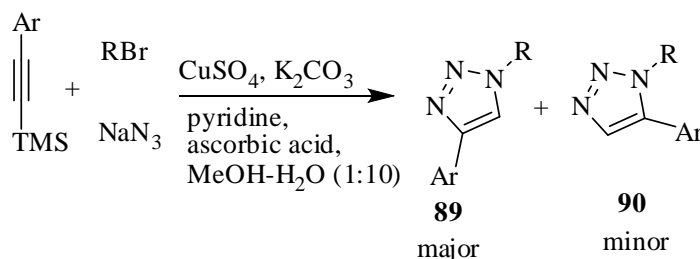

Scheme 73

Sequential one-pot microwave irradiated multicomponent reaction catalyzed by copper is described.<sup>132</sup> Glycosides, alkynes and  $\text{TMSN}_3$  in the presence of  $\text{Cu}(\text{OTf})_2$  and KI under microwave irradiation provides triazole-*O*-glycoconjugates **91** and **92** via Huisgen 1,3-dipolar cycloaddition reaction (Scheme 74).

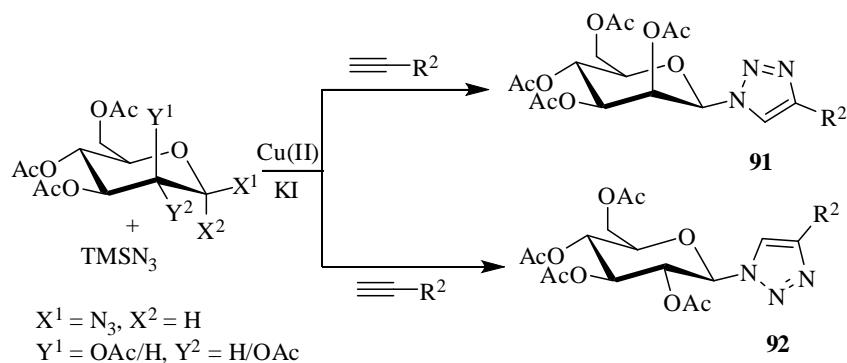

Scheme 74

Terminal acetylene, carbon monoxide, aryl iodide and sodium azide under multicomponent carbonylative Sonogashira reaction provides 4,5-disubstituted 1,2,3-(*NH*)-triazoles **93** and **94** in the presence of palladium catalyst.<sup>133</sup> It is interesting to note that carboxide-free 4,5-disubstituted 1,2,3-(*NH*)-triazoles are obtained instead of 4,5-disubstituted 1,2,3-(*NH*)-triazoles containing carbonyl group when aryl iodide with nitro group is taken, due to the strong electrophilic nature of nitro group of aryl iodide directed to Sonogashira coupling with terminal acetylenes instead of carbonylative Sonogashira reaction. Carbonylative Sonogashira coupling and subsequent 1,3-dipolar cycloaddition leads to the formation of the product. Substituent effect of acetylene is also examined and found that the branch chain aliphatic terminal acetylene smoothly undergoes this reaction, even long chain aliphatic terminal acetylene can promote the process and produce better yield. On the other hand, aromatic acetylene with electron-donating and electron-withdrawing substituent can also readily produce the desire product (Scheme 75).

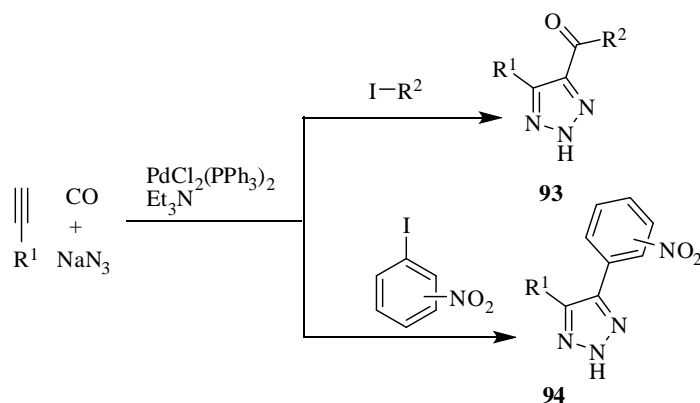

Scheme 75

1,4-Disubstituted 5-iodo-1,2,3-triazole **95** is synthesized from azide, alkynes by trapping the carbanion intermediate with *in situ* generated electrophilic reagent (I<sup>+</sup>) from CuI and NBS through the click reaction. During the reaction CuI provides Cu<sup>+</sup> and I<sup>-</sup>, Cu<sup>+</sup> catalyzed the cycloaddition reaction whereas I<sup>-</sup> in the presence of NBS oxidized to I<sup>+</sup> which then trapped the carbanion and attach to the 5-position of the triazole derivative (Scheme 76).<sup>134</sup>

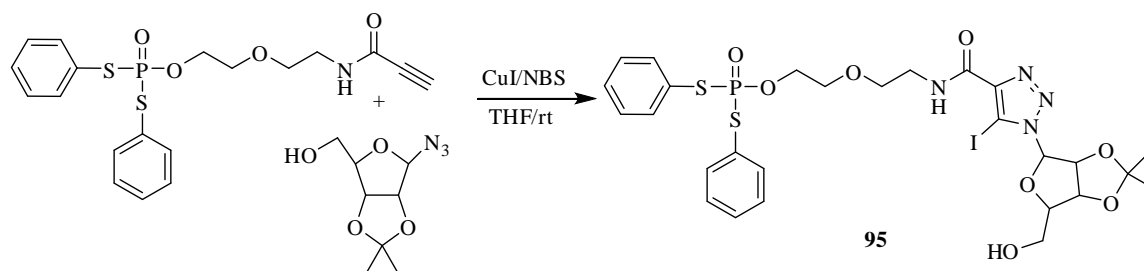

Scheme 76

One-pot multistep tandem click transformations<sup>135</sup> to the synthesis of 1,2,3-triazole **96** from commercially available diazonium salts, terminal or trimethylsilyl-protected alkynes and sodium azide has also been investigated (Scheme 77).

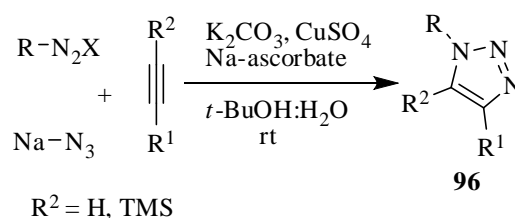

Scheme 77

Copper(I)-catalyzed 1,3-dipolar cycloaddition of azides and terminal alkynes<sup>106,107,136</sup> is considered to be one of the most popular reaction for the synthesis of 1,4-disubstituted 1,2,3-triazoles. *In situ* preparation of aryl azides from aryl halide and subsequent use in 1,2,3-triazole formation minimises the risk related to handling as most of the azides are explosive in nature. Commercially available  $\text{CuBr}(\text{PPh}_3)_3$  is used as a click catalytic system which does not require any additives to afford pure triazoles from terminal alkynes and an azide through *in situ* azide formation from their corresponding halides.<sup>137</sup> Mihovilovic *et al.*<sup>138</sup> reported a tandem catalysis protocol based on decarboxylative coupling of alkynoic acids and 1,3-dipolar cycloaddition of azides prepared *in situ* via three component reaction for the synthesis of a variety of functionalized 1,2,3-triazoles **97** in excellent yields. *In situ* preparation of low molecular weight alkynes from decarboxylation of alkanic acid which are much easier to handle and use in the laboratory conditions makes the protocol more interesting (Scheme 78).

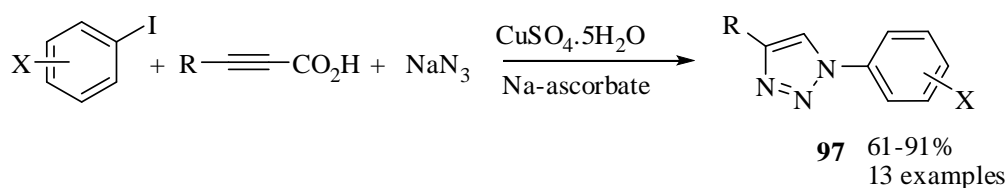

Scheme 78

Aryl azides can be prepared from phenyl boronic acid and sodium azide and subsequently used for 1,3-dipolar cycloaddition reaction using a recyclable heterogeneous clay supported CuO nanoparticles for one-pot synthesis of 1-aryl-1,2,3-triazoles. Sodium azide apart from its role as an azidation reagent, also acts as a reducing agent producing *in situ* click-active Cu(I).<sup>139</sup> Cu(I)-catalyzed azide alkyne cycloaddition (CuAAC) reaction for the synthesis of 1,2,3-triazoles is regioselective, and gives only the 1,4-disubstituted product although the heating between an azide and alkyne gives the regioisomer of 1,4- and 1,5-disubstituted 1,2,3-triazoles. Ruthenium based catalyst for azide alkyne cycloaddition reaction (RuAAC) is more selective to give only the 1,5-disubstituted triazoles under conventional heating or microwave conditions.<sup>140</sup> Ruthenium-catalyzed azide alkyne cycloaddition to afford 1,5-disubstituted 1,2,3-triazoles starting from an alkyl halide, an alkyne and sodium azide is reported.<sup>141</sup> The organic azides were synthesized from *in situ* treatment of primary alkyl halide with sodium azide in DMA under microwave heating followed by subsequent addition of RuClCp(PPh<sub>3</sub>) and alkyne afforded the desired regioselective 1,5-disubstituted triazoles in good yields. One-pot synthetic procedure directly from alkyl halide, sodium azide and alkyne is unsuccessful. This result may be due to the side reaction of ruthenium catalyst with sodium azide. This problem is easily overcome by using *in situ* synthesis of azide from alkyl halide and then subsequent addition of alkyne and ruthenium catalyst to afford desired triazoles **98** in very good conversion (Scheme 79).

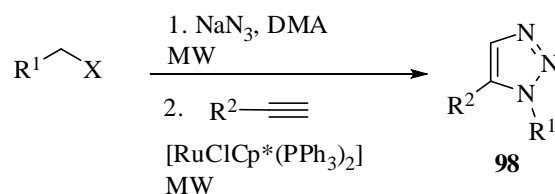

**Scheme 79**

Azide alkyne cycloaddition reaction using either copper catalyst or ruthenium catalyst afforded the triazoles which mainly limited to N-1 position. Reports on direct functionalization at N-2 position of triazoles are very few and suffers various disadvantages. Chen *et al.*<sup>142</sup> developed a metal and base free three component reaction involving an ynones, sodium azide and an alkyl halide for the regioselective synthesis of 2,4,5-trisubstituted 1,2,3-triazoles **99** via azide chalcone oxidative cycloaddition and post-triazole arylation in one-pot (Scheme 80).

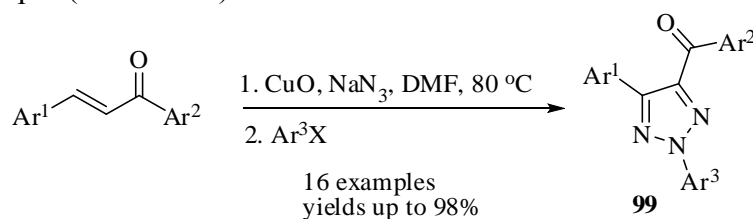

**Scheme 80**

## 2.4 HETEROCYCLES CONTAINING FOUR HETEROATOMS

### 2.4.1 SYNTHESIS OF TETRAZOLES

Trimethyl orthoformate, amines and  $\text{HN}_3$  react to form tetrazoles **100** in good yields in the presence of indium under solvent free condition (Scheme 81).<sup>143</sup>

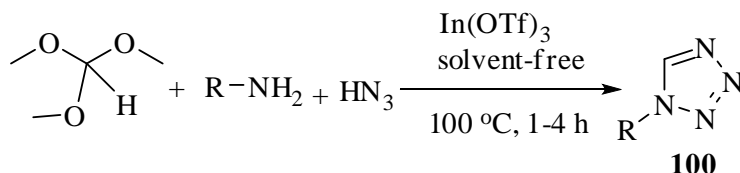

Scheme 81

The enantioselective synthesis of 5-(1-hydroxy-alkyl)tetrazoles **101** by a [(salen)Al<sup>III</sup>Me]-catalyzed three component Passerini reaction of aldehydes, isocyanides and hydrazoic acid is described (Scheme 82).<sup>144</sup>

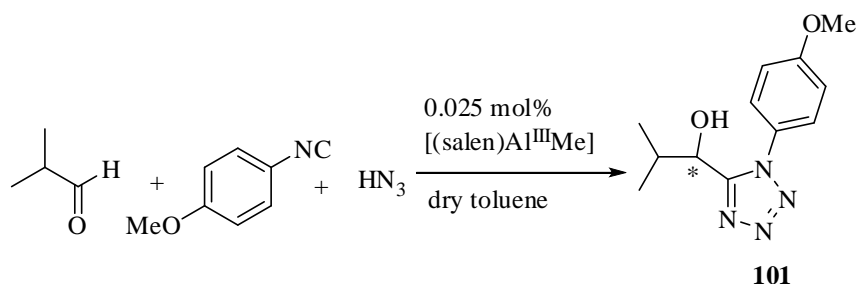

Scheme 82

An isocyanide based four component reactions is investigated<sup>145</sup> leading to the structurally diverse tetrazole derivative **102** as a major product along with a trace amount of amide as side product using In(III) Lewis acid catalyst from aldehyde, isocyanides, trimethylsilyl azide and aliphatic alcohol in refluxing conditions (Scheme 83).

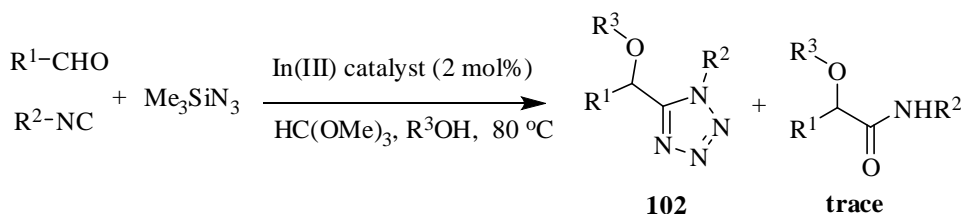

Scheme 83

## 3. CONSTRUCTION OF SIX-MEMBERED HETEROCYCLES

### 3.1 HETEROCYCLES CONTAINING ONE HETEROATOM

#### 3.1.1 SYNTHESIS OF PYRIDINE AND DIHYDROPYRIDONE DERIVATIVES

One-pot synthesis of substituted pyridines **103** from aromatic aldehydes with ethyl acetoacetate and ammonium acetate via a domino cyclization-oxidative aromatization (dehydrogenation) approach has

been reported. This process is based on the use of a new bifunctional Pd/C/K-10 montmorillonite and microwave irradiation (Scheme 84).<sup>146</sup>

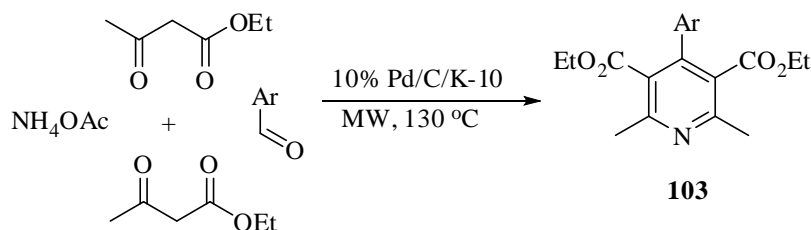

**Scheme 84**

Multicomponent synthesis of 2,4,6-triarylpyridines from acetophenone, aldehyde and ammonium acetate in the presence of bismuth triflate, heating under solvent free condition has been described.<sup>147</sup> It has also been explored the catalytic activity of bismuth triflate towards unexpected acetalization of tetrazoloquinoline-4-carbaldehydes **104** (Scheme 85).

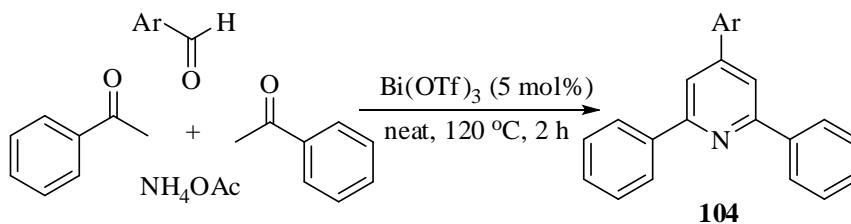

**Scheme 85**

Mixing of methyl acetoacetate, 2 equivalents of aldehyde and 2 equivalents of aniline in the presence of indium trichloride ( $\text{InCl}_3$ ) provides highly substituted piperidine derivatives. This pseudo five component reaction is one-pot, atom and step economic and also diastereoselective. In the presence of Lewis acid first imine and enamine is generated which then undergoes Knoevenagel-like condensation with aldehyde to produce iminium-Knoevenagel intermediate which on subsequent elimination of proton and tautomerization forms a diene. This diene undergoes either aza-Diels-Alder or tandem Mannich-Michael type reaction to afford piperidine derivative **105** (Scheme 86).<sup>148</sup> The group which increases the nucleophilicity on aniline, increases the reaction rate and yield of the products whereas 2-substituted aldehyde, due to the steric effect, provides lower yield and takes longer reaction time. Similar substituted piperidine derivatives **105** is synthesized through multicomponent reaction using same components at room temperature in the presence of  $\text{Bi}(\text{NO}_3)_2 \cdot 5\text{H}_2\text{O}$ . This reaction is high yielding, atom economic, high diastereoselective and environmentally benign (Scheme 86).<sup>149</sup> One-pot multicomponent reaction of aromatic aldehyde, amines, and acetoacetic esters in the presence of aqua-compatible  $\text{ZrOCl}_2 \cdot 8\text{H}_2\text{O}$  has

been developed for the synthesis of functionalized piperidine derivatives.<sup>150</sup> Mechanistically, it is believed that enamine is produced by the reaction between acetoacetic ester and amine. This enamine may then react with aromatic aldehyde to generate a Knoevenagel-type product which undergoes tautomerization to form a non-isolable diene type metal complex. Another equivalent of amine and aldehyde provides imine which subsequently undergoes a [4+2] aza-Diels-Alder reaction with the diene metal complex to afford the functionalized piperidine **105** (Scheme 86).

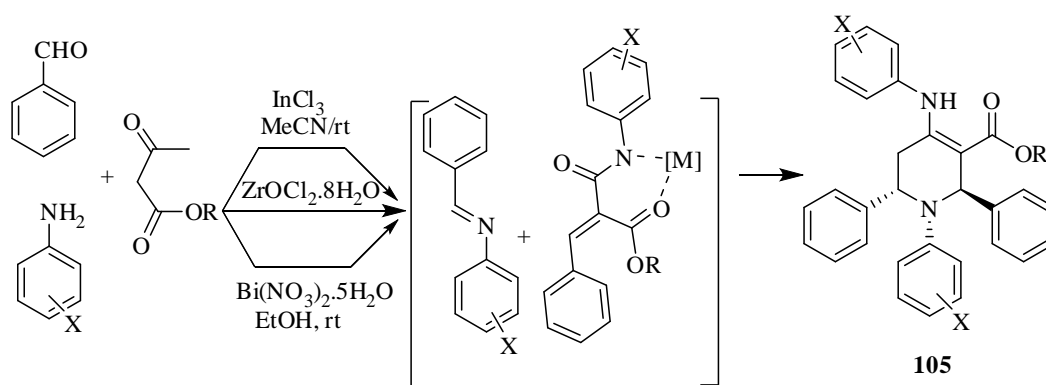

Scheme 86

The multicomponent reaction of alkenyl halides, silylimines and a secondary amine in the presence of a Pd(0) catalyst provides the trisubstituted pyridines **106** (Scheme 87).<sup>151</sup> The Lewis acid-catalyzed aza-Diels-Alder cycloaddition reaction of 2-azadiene, formed by cross coupling of a silylimine with an alkenyl halide, and an enamine, formed by cross coupling of an alkenyl halide with an amine, followed by aromatization gave rise the pyridine derivatives.

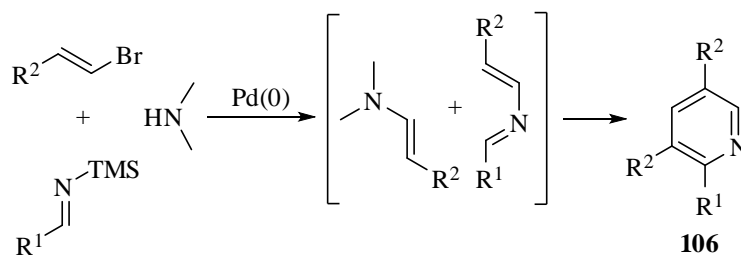

Scheme 87

Compared to base-catalyzed<sup>152</sup> synthesis of 2-amino-3,5-dicarbonitrile-6-thiopyridines **107** using DABCO or triethylamine and conventional heating, the ZnCl<sub>2</sub>-catalyzed one-pot multicomponent reaction<sup>153</sup> using conventional or microwave heating produced the desired product in better yields (Scheme 88). Recently a new convenient and eco-friendly multicomponent reaction of aldehydes, malononitrile and thiophenol is developed<sup>154</sup> for the synthesis of biologically significant highly substituted pyridine derivatives **107** using efficient and reuseable Zn(II) and Cd(II) metal-organic frameworks (MOFs) as a catalyst (Scheme 88). Ultrasound irradiated multicomponent approaches to 2-

amino-6-(arythio)-4-arylpiperidine-3,5-dicarbonitrile derivatives from aryl aldehydes, malononitrile and thiols using  $\text{ZrOCl}_2 \cdot 8\text{H}_2\text{O}/\text{NaNH}_2$  as a catalyst in ionic liquid has been demonstrated. The mechanistic path depicted as initially a Knoevenagel adduct is formed by the reaction between malononitrile and aldehyde. Michael addition of this Knoevenagel adduct to a second molecule of malononitrile takes place, followed by an addition of thiolates to the nitrile groups of Michael addition product. Subsequent cyclization, aromatization and aerial oxidation afforded the corresponding pyridine derivatives **107** (Scheme 88).<sup>155</sup>

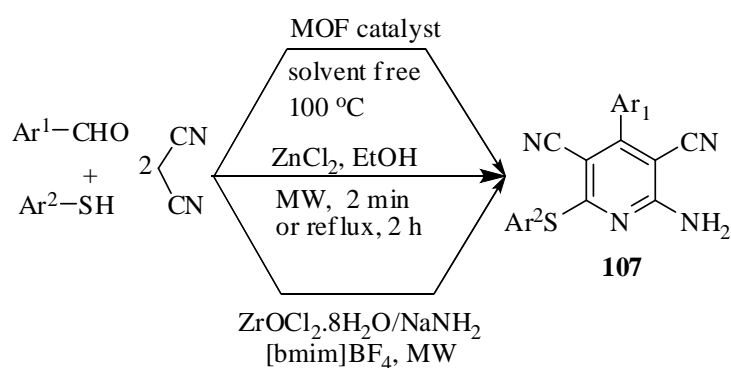

**Scheme 88**

The use of ytterbium perfluorooctanoate for a straightforward and efficient synthesis of 2-amino-3-cyanopyridine derivatives **108** via one-pot multicomponent reaction of aldehydes, ketone, malononitrile and ammonium acetate has been achieved by Wang *et al.*<sup>156</sup> They have investigated the positional effect of substituent of aldehydes and disclosed that the *o*-substituted aromatic aldehydes failed to produce any product while *p*- and *m*-substituted aldehyde smoothly provides the desired products. Electron-deficient aromatic aldehyde and various aromatic ketones are suitable for this transformation (Scheme 89).

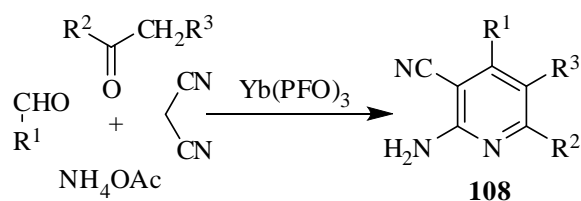

**Scheme 89**

Efficient one-pot multicomponent approaches to the synthesis of polysubstituted dihydropyridines from carbonyl compounds, malononitrile and acetonitrile using indium triflate has been described.<sup>157</sup> It is also reported that the acetaldehyde did not afford the required product and aromatic aldehyde gave complex mixture which is not further investigated. The reaction seems to proceed via condensation-addition reaction leading to the formation of poly-substituted pyridine derivatives **109** in gram scale level (Scheme 90).

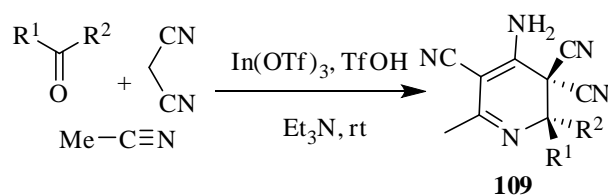

Scheme 90

Ammonium acetate ( $\text{NH}_4\text{OAc}$ ) is widely used as an ammonia source in various organic transformation.<sup>158</sup> Recently palladium-catalyzed microwave-assisted one-pot reaction protocol for the synthesis of isoquinilones **110** from 2-bromoarylaldehydes, terminal alkynes, and ammonium acetate has been described (Scheme 91).<sup>159</sup>

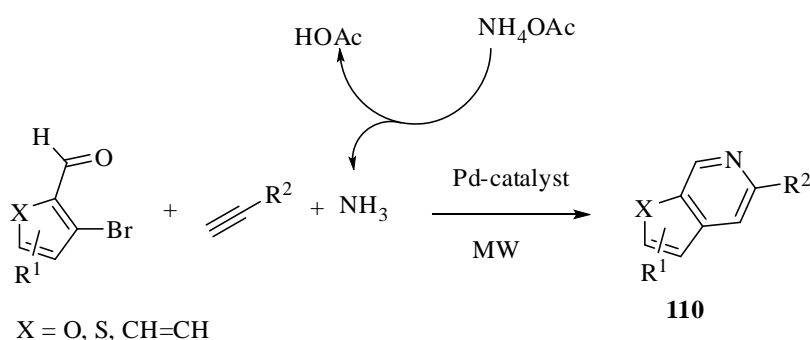

Scheme 91

Cerium ammonium nitrate (CAN)-catalyzed convenient approach to 1,4-dihydropyridines **111** from 1-azadiene-based multicomponent reaction is developed.<sup>160</sup> The 1-azadiene is generated *in situ* by the condensation of aromatic amines and  $\alpha,\beta$ -unsaturated aldehydes and, in the same pot,  $\alpha,\beta$ -dicarbonyl compound is added to provide the 1,4-dihydropyridines (Scheme 92). The use of aliphatic amines or  $\alpha,\beta$ -unsaturated aldehydes except cinnamaldehyde derivatives produced complex reaction mixtures with the lower yield of the desired products.

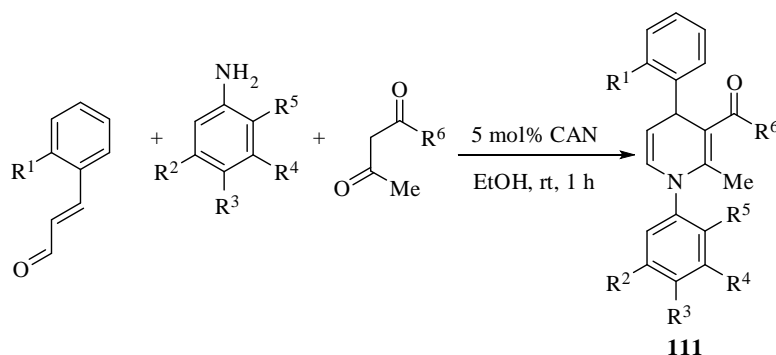

Scheme 92

Ytterbium triflate-catalyzed synthesis of dihydropyridines (DHP) through three component reaction is reported.<sup>161</sup> The reaction of anilines, benzaldehyde and 3,3-diethoxypropionate under refluxing condition

in the presence of  $\text{Yb}(\text{OTf})_3$  as catalyst affords the DHPs in good yields. The reaction is involved the followings steps: formation of imine and tautomerization of subsequent imine to enamine which further reacts with aldehyde to form enaminoalcohol. Dehydration of the enaminoalcohol affords  $\alpha,\beta$ -unsaturated imine. Finally Michael type annulations and elimination of amine affords the desire product **112** (Scheme 93).

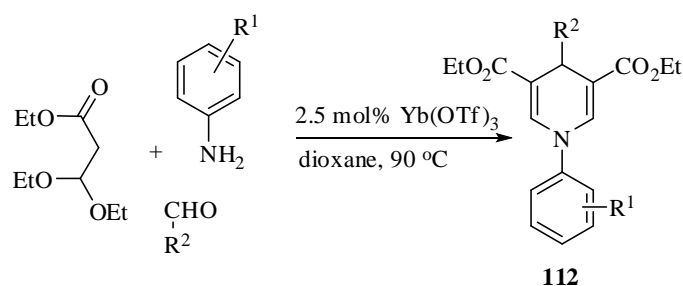

**Scheme 93**

Microwave-assisted eco-friendly four component reaction of 3-amino-9-ethylcarbazole, malononitrile, aromatic aldehydes and acetylenic esters for the synthesis of *N*-carbozolyldihydropyridines **113** using indium trichloride as catalyst is developed.<sup>162</sup> The transformation is believed to proceed via Knoevenagel condensation, Michael addition, followed by tautomerization leading to the formation of products (Scheme 94).

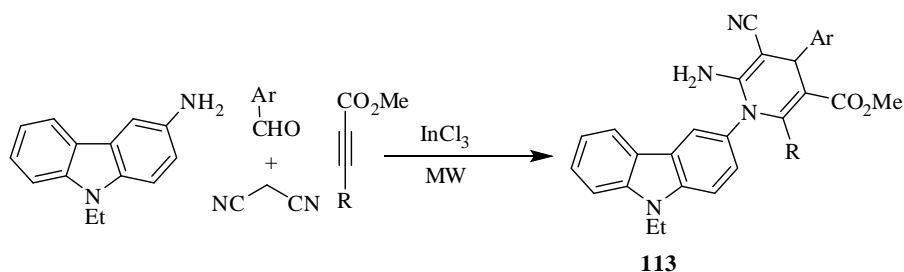

**Scheme 94**

A simple and facile method for the synthesis of pyrazolo[3,4-*b*]pyridine and pyrazolo[1,5-*a*]pyrimidine with more structural diversities in the presence of KF-alumina at refluxing condition has been described (Scheme 95).<sup>163</sup>

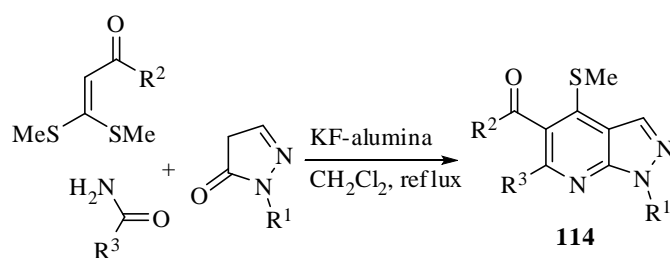

**Scheme 95**

*In situ* generated 2-azadienes based multicomponent reaction of 3-aminocoumarin, benzaldehyde, and various electron-rich alkenes in the presence of  $\text{Yb}(\text{OTf})_3$  to afford 1,2,3,4-tetrahydropyrido[2,3-*c*]-coumarins **115** has been developed.<sup>164</sup> Some of these products have been oxidized into the corresponding pyrido[2,3-*c*]coumarins **116** using various oxidants, such as  $\text{Br}_2$  and  $\text{NaIO}_4$  and nitrous gases (Scheme 96).

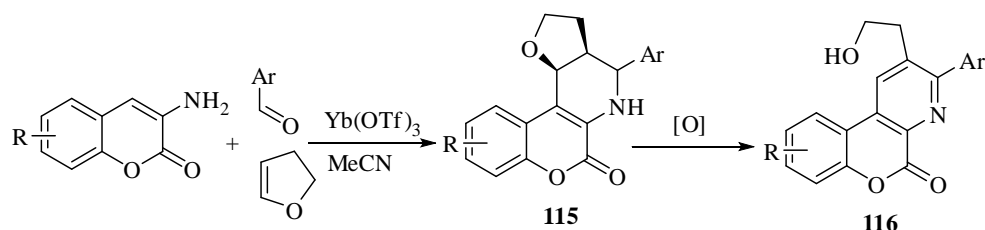

Scheme 96

The reaction of diketene, *N*-tosylimines and aldehydes using  $\text{TiCl}_4$  as a Lewis acid catalyst for the synthesis of 2,6-disubstituted piperidin-4-ones **117** is reported (Scheme 97).<sup>165</sup> The product is obtained as a mixture of diastereomers, which could be converted into a single diastereomer by treatment with  $\text{K}_2\text{CO}_3$ .

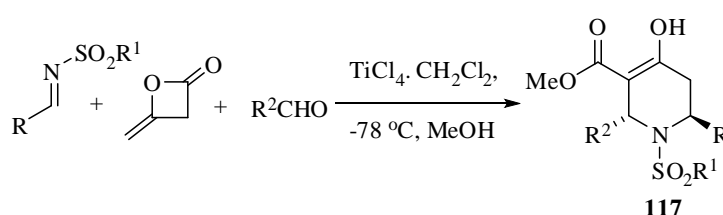

Scheme 97

One-pot, three component reaction of nitroarenes, aldehydes and Danishefsky's diene using  $\text{In}(0)$  as a reducing agent as well as a precatalyst for the *in situ* generation of  $\text{In}^{3+}$  for the access of dihydropyridin-4-ones is reported **118** (Scheme 98).<sup>166</sup> Mechanistically,  $\text{In}(0)$  in the presence of  $\text{NH}_4\text{Cl}$  generates  $\text{InCl}_3$  as the reaction byproduct and catalyzed the aza-Diels-Alder cycloaddition reaction in a one-pot tandem sequence between the imine and then added diene to afford the desire product.

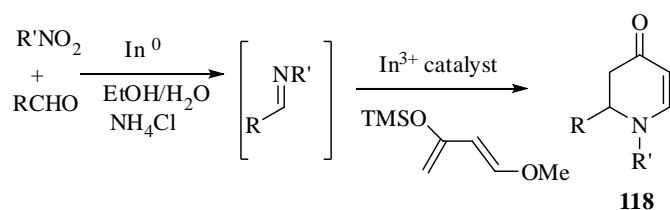

Scheme 98

An enol ester (3,4-dihydro-6-methyl-2*H*-pyran-2-one) as the electron-rich alkene has been used to expand the synthetic versatility of the Povarov reaction for the synthesis of *N*-aryl lactam **119**. Treatment of this enol ester with *p*-toluidine and ethyl glyoxalate under  $\text{Sc}(\text{OTf})_3$  catalysis in MeCN at room temperature

provided the *N*-aryl lactam **119** (25%) as the major product, instead of the Povarov adduct **119a** (Scheme 99).<sup>167</sup>

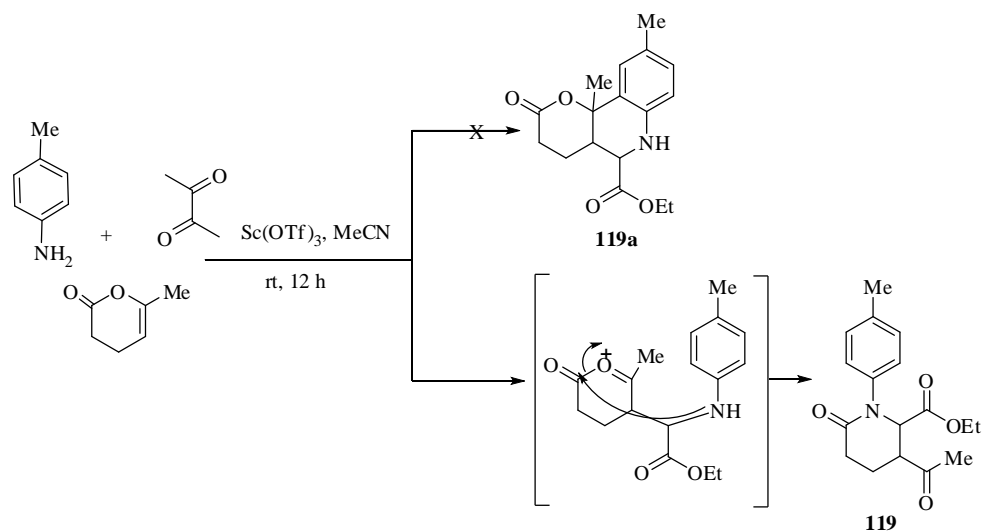

Scheme 99

### 3.1.2 SYNTHESIS OF TETRAHYDROQUINOLINE, QUINOLINE AND ISOQUINOLINE DERIVATIVES

A novel and practical one-pot multicomponent synthesis of isomeric ellipticine derivatives with high diastereoselectivity through intermolecular imino Diels-Alder reaction of 3-aminocarbazoles and benzaldehyde with 3,4-dihydro-2*H*-pyran in the presence of  $\text{InCl}_3$  as catalyst in ionic liquid is described (Scheme 100).<sup>168</sup>

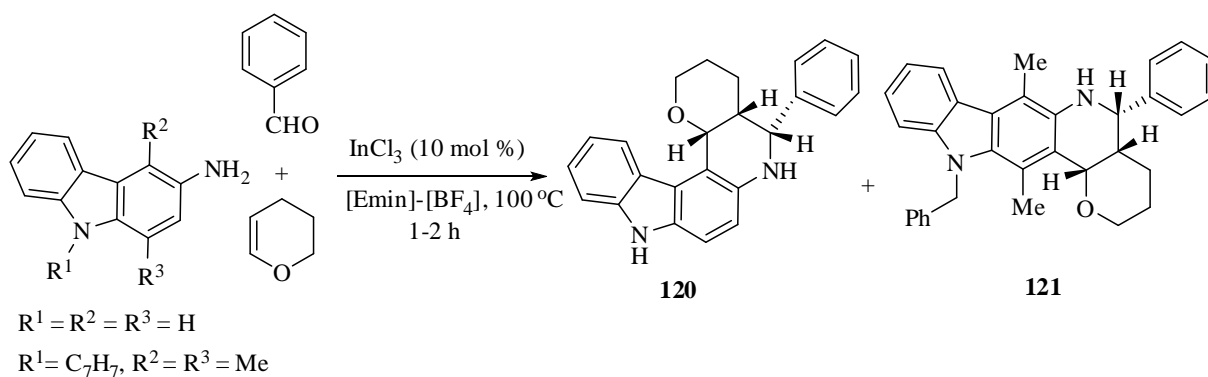

Scheme 100

One-pot three component Povarov reaction using inexpensive catalyst for the synthesis of diastereoselective furano[3,2-*c*]quinolines **122** and **123** have developed. Easily available starting material such as aldehyde, arylamine and dihydropyran or dihydrofuran in the presence of ferric sulphate refluxing in acetonitrile gives quinoline derivatives in good yields via the formation of aldimine followed by Diels-Alder reaction (Scheme 101).<sup>169</sup> Recently furan and pyranoquinoline derivatives **122** and **123** were

synthesized<sup>170</sup> by Povarov multicomponent reaction using niobium pentachloride as an inexpensive and commercially available catalyst in room temperature. This reaction provides good yields and high diastereoselectivity with lower molar concentration of the catalyst (Scheme 101).

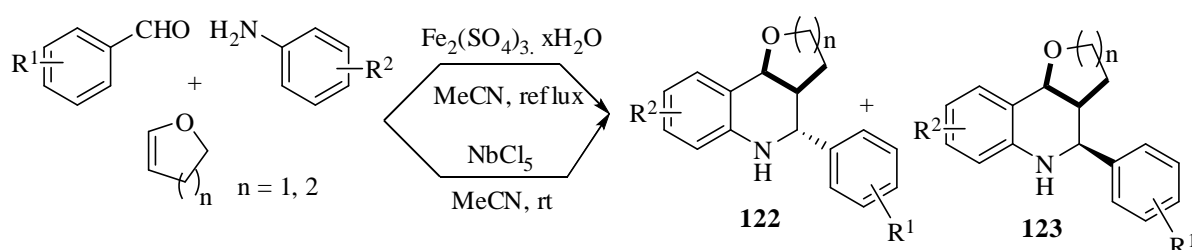

Scheme 101

Unsaturated lactams with *endo*- or *exo*-cyclic double bonds undergo a multicomponent reaction with aldehydes and aniline derivatives, to afford structurally diverse products (Scheme 102) in the presence of  $\text{Sc}(\text{OTf})_3$  as catalyst. A simple Povarov product **124** is obtained when  $\text{R}^4 = \text{H}$ , but due to steric effect final electrophilic substitution does not take place when lactam contains methyl group ( $\text{R}^4 = \text{Me}$ ), produced the Mannich-type product **125**, in moderate yields, instead of the desired Povarov product from the reaction with *p*-toluidine or 4-methoxyaniline and ethyl glyoxalate, under the usual conditions. Interestingly, the adduct **126** in moderate yields is obtained when glyoxylic acid ( $\text{R}^1 = \text{CO}_2\text{H}$ ) is used as the carbonyl component, which acts as a nucleophile and captures the final iminium ion intermediate. Under similar reaction conditions the spiro-Povarov adduct **127** is obtained in low yield (20%) when pyrrolidone derivative with an *exo* double bond is employed, (Scheme 102). Better yield is obtained when the reaction is carried out under microwave irradiation.<sup>171</sup>

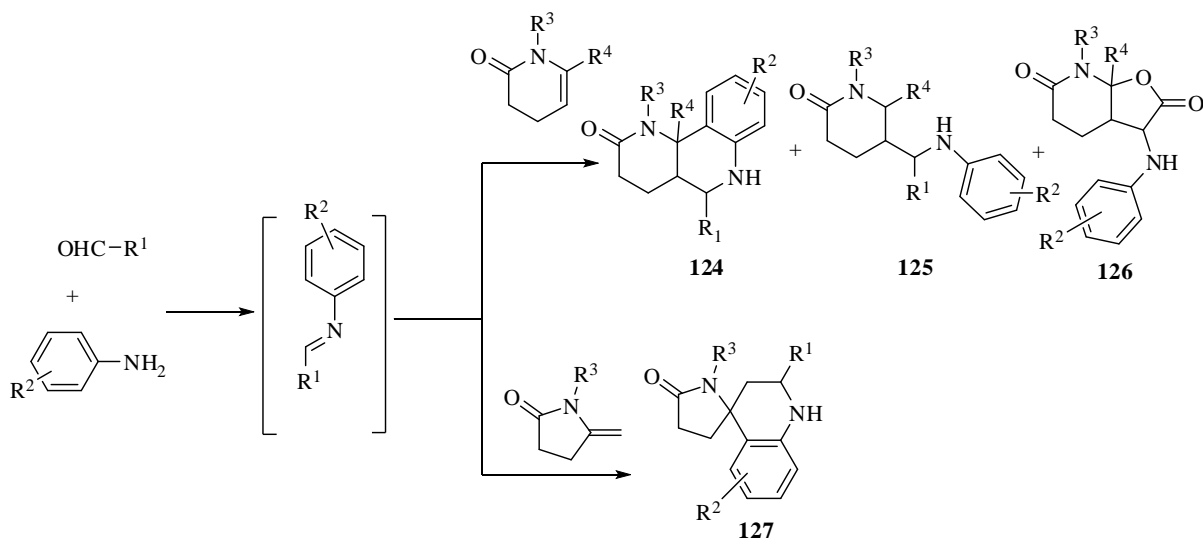

Scheme 102

Recently Povarov multicomponent reaction for the synthesis of tetrahydroquinoline and quinoline derivative is developed.<sup>172</sup> Anhydrous acetonitrile solution of aldehyde, aniline and reactive electron rich oxa-, thia-, and imidazolones' olefin component undergoes reaction in the presence of  $\text{Sc}(\text{OTf})_3$  at room temperature with microwave irradiation to afford the tetrahydroquinoline adduct, which on oxidation with DDQ gave quinoline derivatives in good yields. The silent feature of this reaction is the high regioselectivity affording predominated *cis*-stereoisomer in all cases (Scheme 103).

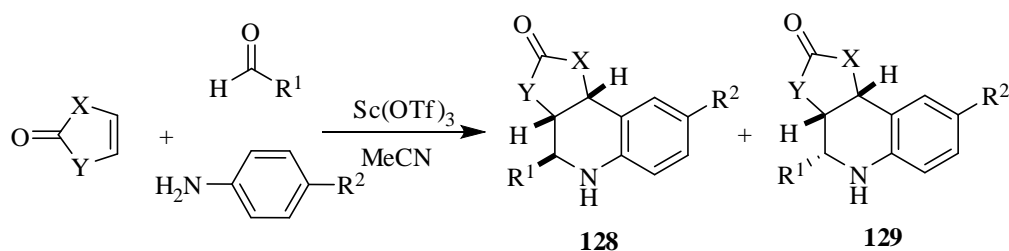

Scheme 103

Multicomponent reaction of aldehyde, naphthalen-2-amine and but-2-ynedioate in the presence of  $\text{Yb}(\text{OTf})_3$  forms 3-arylbenzoquinoline-1,2-dicarboxylate derivatives **130** via imino-Diels-Alder reaction. Aliphatic aldehyde is not suitable for this methodology whereas both electron-donating and electron-withdrawing functionality in aromatic aldehydes are compatible for this reaction (Scheme 104).<sup>173</sup>

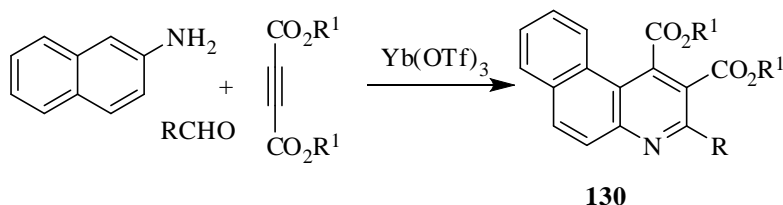

Scheme 104

A high yielding, solvent free multicomponent synthesis of polyhydroquinoline derivatives **131** using nickel nanoparticles as a heterogeneous catalyst via Hantzsch protocol (Scheme 105) has recently been published.<sup>174</sup> The catalytic efficacy of Pd-nanoparticle was investigated through one-pot multicomponent reaction of aromatic aldehydes, cyclic 1,3-dicarbonyl compounds, ethyl acetoacetate or ethyl cyanoacetate and ammonium acetate for the synthesis of polyhydroquinoline derivatives **131**. The efficacy of Pd-nanoparticles in different solvents was also investigated and among them THF afforded excellent conversion (Scheme 105).<sup>175</sup>

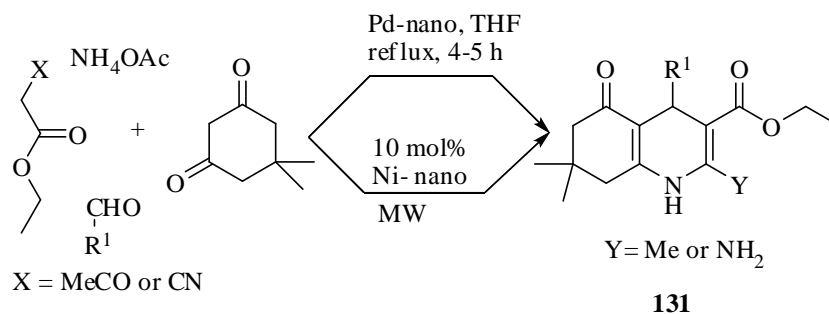
**Scheme 105**

An effort towards the synthesis of pyrimidine or pyrazole annulated heterocycles **132** via one-pot three component condensation reaction of aldehyde, aminouracil or aminopyrazole and 1,3-diketone refluxed in water using 20 %  $\text{InCl}_3$  as catalyst has been reported (Scheme 106).<sup>176</sup>

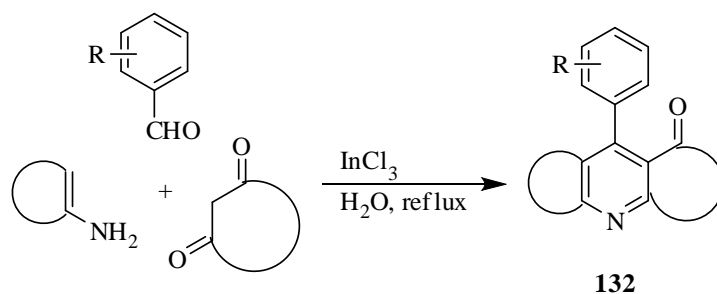
**Scheme 106**

Some novel dihydropyridopyrimidine derivatives **133** have been synthesized via three component reaction<sup>177</sup> of aryl aldehyde, *N,N*-dimethyl-6-aminouracil and cyanoacetylindol refluxing in ethanol using  $\text{InCl}_3$  as catalyst for 6 h. It is also observed that aromatic aldehyde having electron-withdrawing functional group affords high yield (Scheme 107).

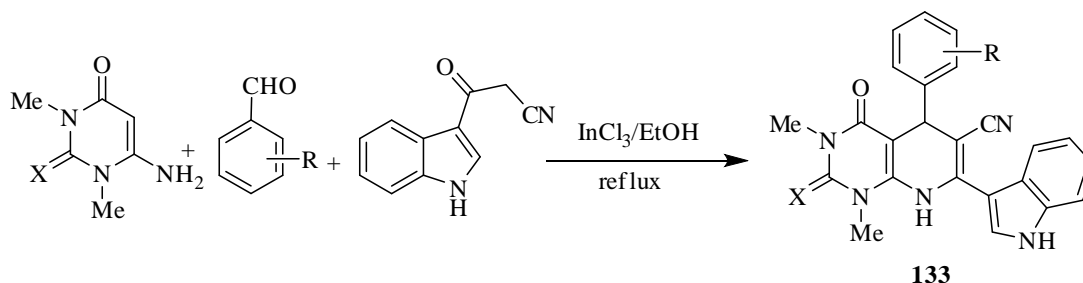
**Scheme 107**

Palladium-catalyzed, microwave-assisted, multicomponent reactions starting from *o*-bromoarylaldehydes, terminal alkynes, and aqueous ammonia for the synthesis of substituted isoquinoline derivatives **134** has been developed (Scheme 108).<sup>178</sup>

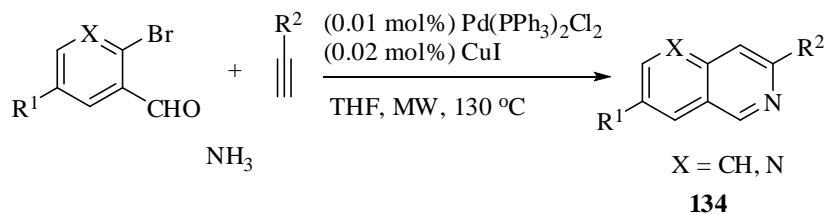
**Scheme 108**

An efficient and high yielding procedure for the synthesis of pyrrolo[3,2-*f*]quinoline **135** and pyrrolo[2,3-*h*]quinoline derivatives **136** has been reported<sup>179</sup> by one-pot multicomponent reaction of easily available starting material such as benzaldehydes, indoloamines, and phenylacetylenes in the presence of La(OTf)<sub>3</sub> as catalyst in good yield by heating in ionic liquid. Among the two different pyrroloquinoline derivatives, pyrrolo[3,2-*f*]quinoline is formed as major product via normal path of [4+2] cycloaddition whereas pyrrolo[2,3-*h*]quinoline derivative is formed via an unexpected [3+2] cycloaddition pathway between phenylacetylene and azadiene (Scheme 109).

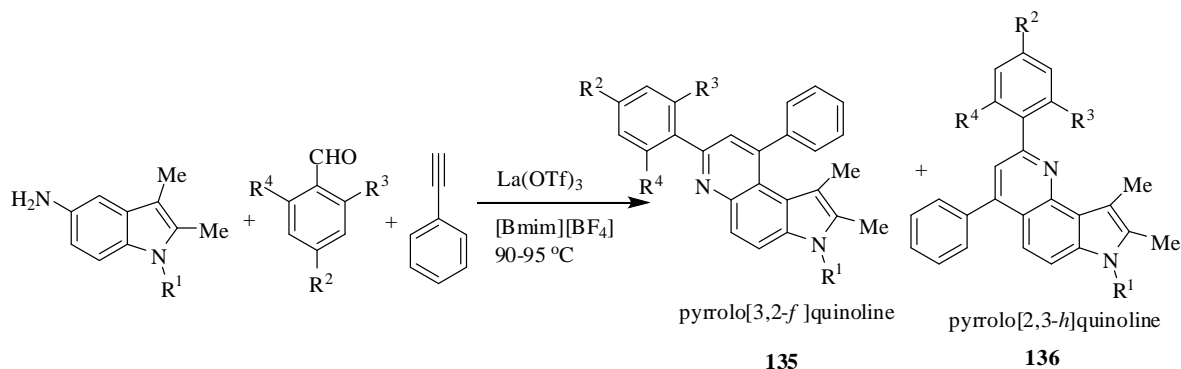
**Scheme 109**

Straightforward and efficient three component reaction is demonstrated<sup>180</sup> for the synthesis of quinolines **137** using environment friendly and reusable ytterbium triflate as catalyst from easily available starting material such as aldehyde, alkynes and amines under microwave irradiation in an ionic liquid as green solvent (Scheme 110).

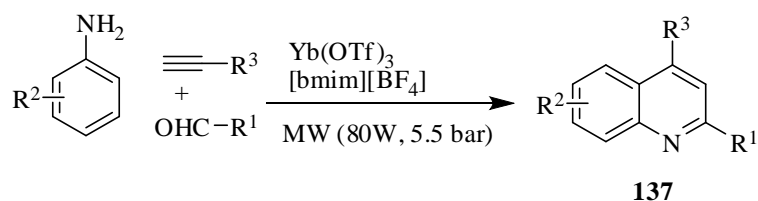
**Scheme 110**

1,2-Dihydroisoquinolines are of interest because of their frequent occurrence in nature and their wide range of biological and physiological effects.<sup>181,182</sup> The search for better hits encouraged to construct structural novel 1,2-dihydroisoquinoline library for the subsequent biological assays. Tandem or cascade

reactions and multicomponent reactions offer significant advantages over traditional approaches for the rapid construction of several bonds in a single synthetic procedure. Recently  $\text{Rh}_2(\text{OAc})_4$  and  $\text{AgOTf}$  catalyzed tandem cyclization/three component reaction of 2-alkynylaryldimines, diazo compounds, and water or alcohols to afford functionalized 1,2-dihydroisoquinolines **138** is reported (Scheme 111).<sup>183</sup>

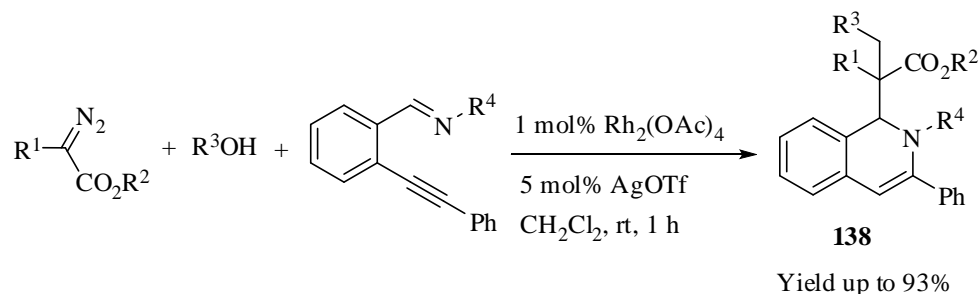

Scheme 111

Silver(I)-catalyzed intramolecular cyclization and Cu(II)-catalyzed oxidation of an aliphatic C-H bond of tertiary amine leading to isoquinoline derivatives has been reported by Wu *et al.*<sup>184</sup> Reaction of 2-alkynylbenzaldehyde, sulfohydrazide and a tertiary amine in the presence of Cu(II) and Ag(I) salts afforded an unexpected *H*-pyrazolo[5,1-*a*]isoquinolines **139** in good yields (Scheme 112).

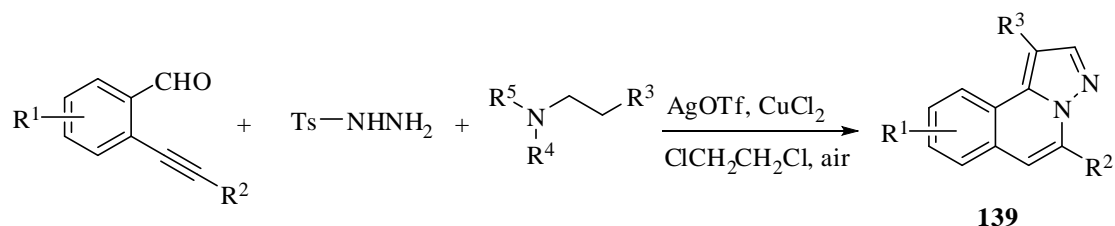

Scheme 112

C-H Bond activation and annulation is one of the most efficient methodologies for the formation of isoquinoline derivatives. Miura *et al.*<sup>185</sup> has reported an efficient method for the formation of polysubstituted isoquinoline derivatives based on rhodium-based C-H activation of benzophenone imines with alkynes. Recently Chen *et al.*<sup>186</sup> has reported  $\text{RhCp}^*\text{Cl}_2$ -catalyzed three component reaction of aryl halides, methylamine and alkyne through C-H bond activation for the regioselective formation of isoquinolinium salt **140** (Scheme 113).

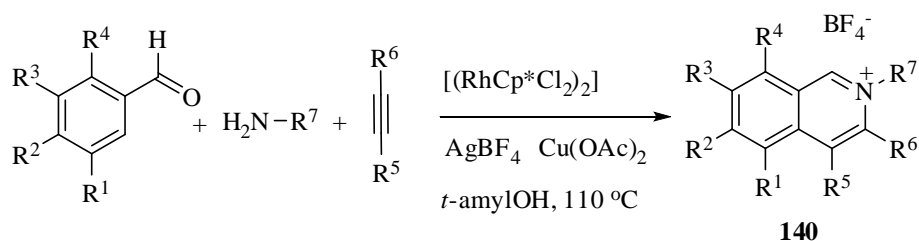

Scheme 113

The same strategy of C-H bond activation and annulation reaction for the formation of isoquinolinium salts has been described by the same group<sup>187</sup> using less expensive ruthenium-based catalyst as compared to the rhodium one. Copper(I)-catalyzed electrophilic tandem cyclization of 2-ethynylbenzaldehyde with *o*-benzenediamines and iodine for the formation of iodoisoquinoline fused benzamidazoles **141** is reported by Ouyang *et al.* (Scheme 114).<sup>188</sup>

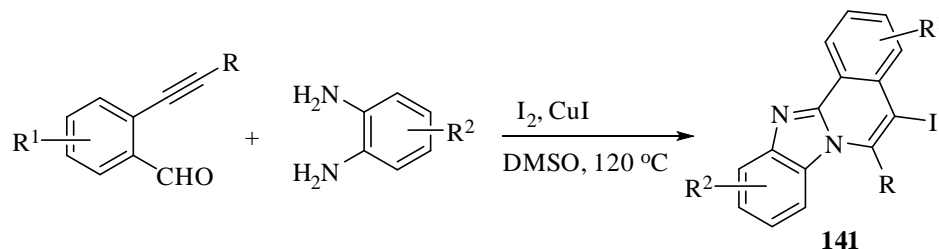

Scheme 114

Iodoisoquinoline smoothly undergoes the Suzuki (**142**), Sonogashira (**143**) and Heck (**144**) coupling reactions, respectively, in excellent yields (Scheme 115).

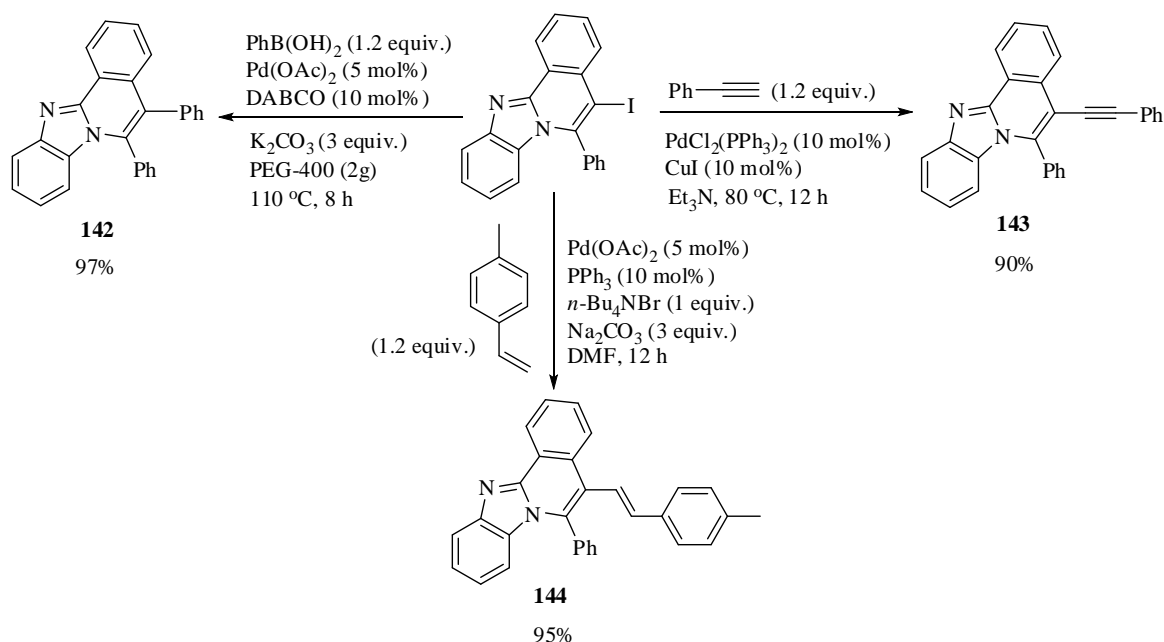

Scheme 115

Pd, Cu, and Ag salts have been demonstrated effectively for activation of triple bond which provides an efficient route for the synthesis of various heterocyclic systems.<sup>189</sup> A parallel diversity-oriented synthesis of 1-(1*H*-imidazol-1-yl)-1,2-dihydroisoquinoline derivatives **145** via AgOTf-catalyzed three component reaction of 2-alkynylbenzaldehyde, amine, and imidazole has been reported (Scheme 116).<sup>190</sup>

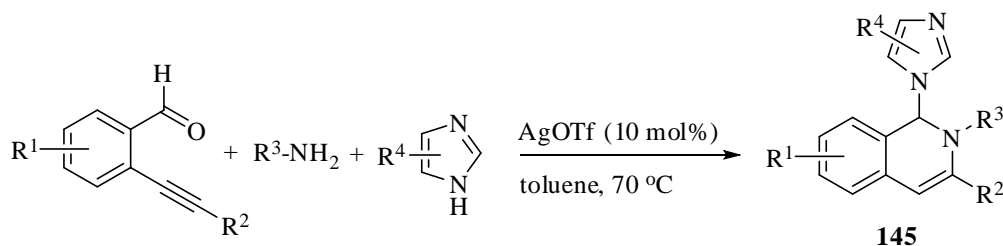

Scheme 116

Pd/C-catalyzed multicomponent reaction of 1,2-dichloroquinoxaline, hydrazine, phenylacetylene and a variety of aldehydes for the construction of pyrrole ring is reported recently. *In situ* formation Pd(0) and in the presence of Cu(I) catalyst catalyzes the Sonogashira coupling reaction and finally triple bond activation followed by intramolecular cyclization to afford the pyrrolo[2,3-*b*]quinoxalines **146** (Scheme 117).<sup>191</sup>

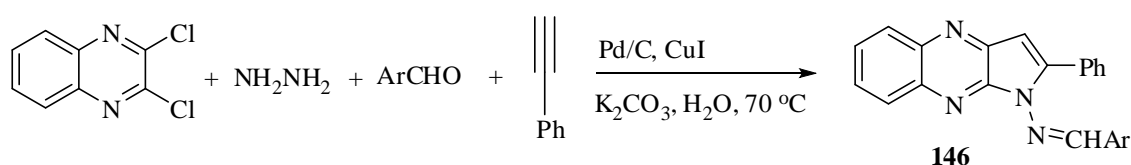

Scheme 117

Hua *et al.* has described<sup>192</sup> an one-pot three component reaction for the synthesis of isoquinolines and fused pyridine heterocycles from aryl ketones, hydroxylamine, and alkynes catalyzed by rhodium. The reaction involves condensation of aryl ketones and hydroxylamine, C–H bond activation of the *in situ* generated aryl ketone oximes catalyzed by Rh(III), and cyclization with internal alkynes which finally afford the isoquinolines and fused pyridines **147** in excellent yields (Scheme 118).

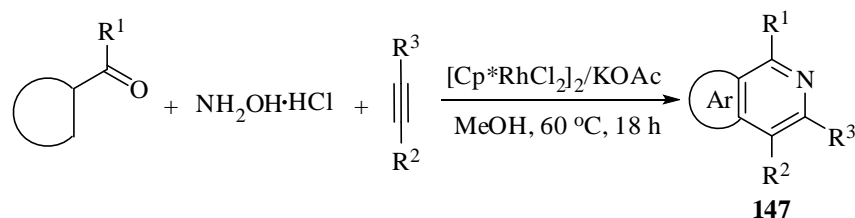

Scheme 118

Three component reactions of nitroarenes, aldehyde and phenylacetylene for the synthesis of quinoline derivatives **148** by using indium metal in the presence of diluted hydrochloric acid has been demonstrated.<sup>193</sup> The reaction procedure involves reduction of the nitroarenes to aniline, coupling with aniline, aldehyde and terminal alkynes, cyclization and dehydrogenation leading to the formation of the product in good yield (Scheme 119).

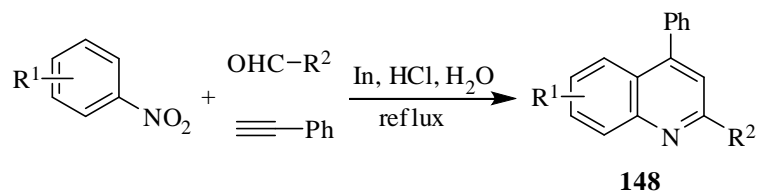

Scheme 119

The Cu(I) iodide-catalyzed multicomponent reaction of 2-ethynylbenzaldehyde, paraformaldehyde, diisopropylamine and *t*-butylamine affords isoquinoline derivative **149** (Scheme 120).<sup>194</sup>

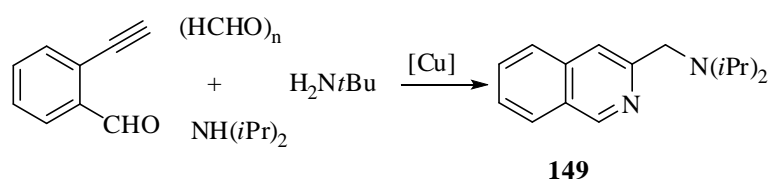

Scheme 120

A new multicomponent reaction of arynes with isocyanides and terminal alkynes to afford pyridine or isoquinoline derivatives in good to high yields, depending upon the reaction conditions which include the ratio of the reagent and solvents, has been developed.<sup>195</sup> It is interesting to note that this one-pot multicomponent regioselective synthesis of polysubstituted pyridines **150** and isoquinolines **151** is difficult to achieve through conventional methods (Scheme 121).

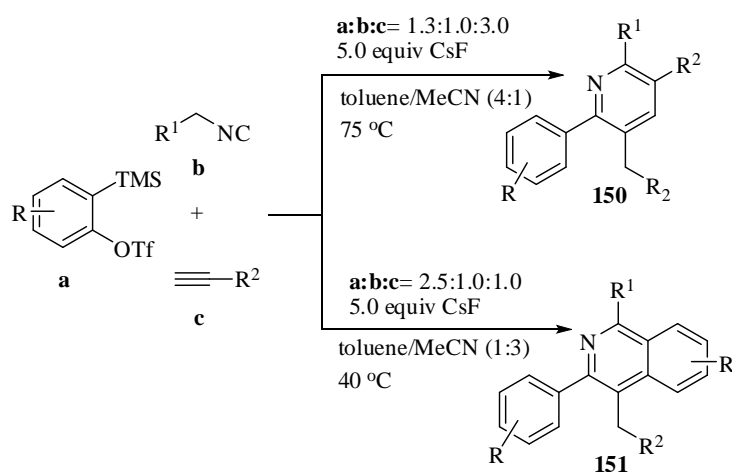

Scheme 121

Silver triflate and triphenylphosphine cocatalyzed reaction of 2-alkynylbenzaldehydes, amines and  $\alpha,\beta$ -unsaturated ketones for the synthesis of functionalised 1,2-dihydroisoquinolines **152** in moderate to good yields has been reported (Scheme 122).<sup>196</sup> According to the proposed mechanism, the triple bond coordinates to the silver salt and, subsequently, the nitrogen atom of the imine attacks the activated triple

bond via 6-*endo* cyclization to afford an isoquinolinium intermediate. In the meantime, triphenylphosphine attacks the  $\alpha,\beta$ -unsaturated ketone as a nucleophilic catalyst, affords enolate, which then undergoes intermolecular attack of the isoquinolinium intermediate to generate the phosphonium species. Finally, elimination of phosphine gives the desired product.

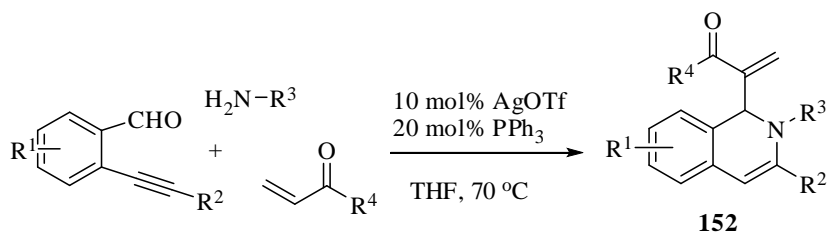

Scheme 122

One-pot three component reaction of 2-alkynylaryl aldehyde, primary amines and terminal alkynes for the preparation of dihydroisoquinoline derivative **153** using pybox as a ligand and copper(I) as a catalyst via tandem addition/cyclization mechanism has been reported (Scheme 123).<sup>197</sup>

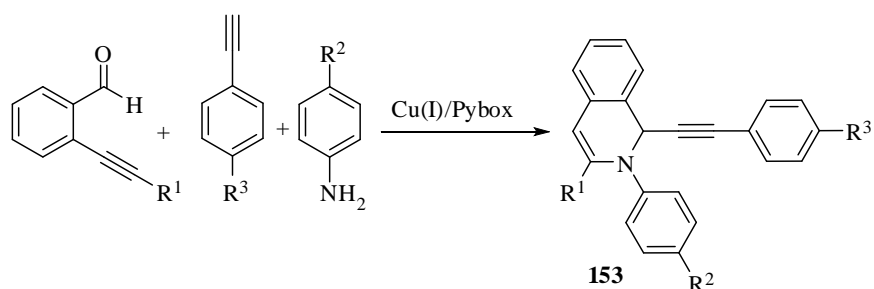

Scheme 123

An efficient route to the synthesis of 1,2-dihydroisoquinolin-1-ylphosphonate **154** is described. This tandem multicomponent reaction of 2-bromobenzaldehyde, alkyne, amine and diethyl phosphite in the presence of palladium and copper as combine catalyst affords the above mentioned product. This reaction is believed to proceed via Sonogashira-intramolecular cyclization and nucleophilic addition reaction (Scheme 124).<sup>198</sup>

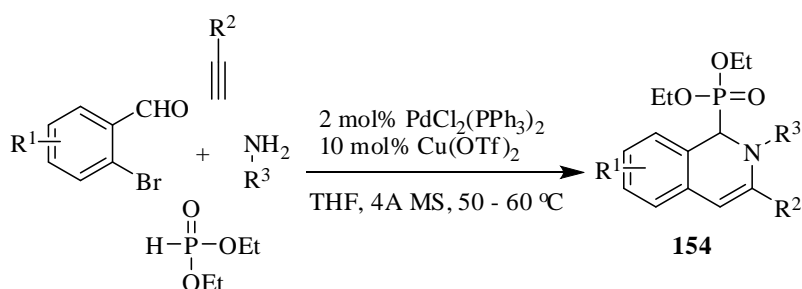

Scheme 124

### 3.1.3 SYNTHESIS OF QUINOLONE AND ISOQUINOLONE DERIVATIVES

The four component mixture of aldehyde, diethyl malonate, dimedone and ammonium acetate on refluxing in water in the presence of ZnO as catalyst afforded octahydroquinolinediones **155** in good yields. This methodology is eco-friendly, simple, efficient and mild one (Scheme 125).<sup>199</sup>

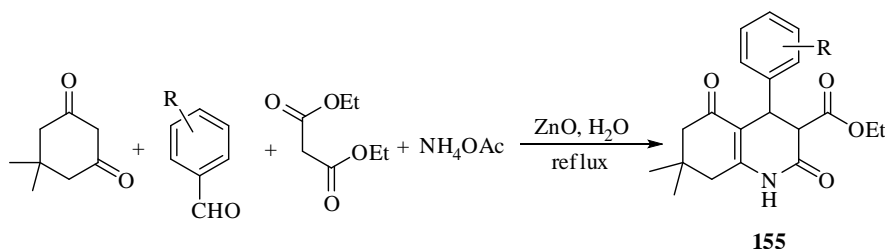

Scheme 125

The selective synthesis of 2-phenyl-4-quinolone **156** in good yield by the use of heterogeneous catalysts associating the [Pd(PNP)]@SBA-15 catalyst to a grafted amine catalyst as [NH<sub>2</sub>(CH<sub>2</sub>)<sub>3</sub>]@SBA-3 in a mechanical mixture from *o*-iodoaniline, phenylacetylene and in the presence of carbon monoxide is reported (Scheme 126).<sup>200</sup> It is interesting to note that such an approach decreases the palladium contamination in the final products found only 3 to 5 ppm of palladium compared to using homogenous catalytic system, where 40 ppm of palladium is found with final product.

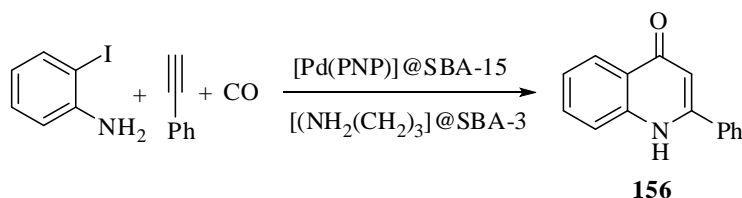

Scheme 126

An approach to cyclocarbonylation is realized through the palladium-catalyzed one-pot reaction of diethyl (2-iodophenyl)malonates and imidoyl chlorides using palladium(II) acetate, tri(2,6-dimethoxyphenyl)phosphine (TDMPP) and diisopropylethylamine in tetrahydrofuran under carbon monoxide (400 psi) to provide the highly substituted isoquinolin-1(2*H*)-ones **157** (Scheme 127).<sup>201</sup>

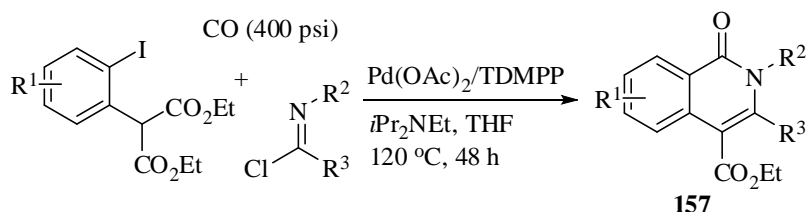

Scheme 127



### 3.1.4 SYNTHESIS OF PYRAN AND LACTONE DERIVATIVES

Exploitation of the catalytic efficacy of Mg/Al hydrocalcite has enabled the microwave, solvent free synthesis of 2-aminochromenes **163** by utilizing the components, 1-naphthol, aromatic aldehydes and malononitrile as outlined in Scheme 131.<sup>205</sup>

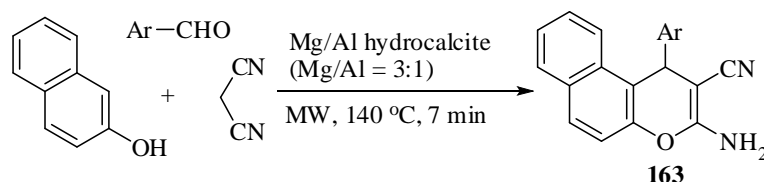

Scheme 131

GaCl<sub>3</sub>-catalyzed three component reaction for the synthesis of 1,3-disubstituted benzochromene **164** is reported. This new approach for the preparation of benzochromene from 2-naphthol, alkyne and aldehyde mechanistically proceeds either via the formation of vinyl naphthalen-2-ol from arylation of alkyne to 2-naphthol and subsequent cyclization of aldehyde with vinyl naphthalene providing the product or via formation of propargyl alcohol and propargyl ether from aldehyde and alkyne which then undergo Claisen rearrangement and subsequent cyclization resulting the product (Scheme 132).<sup>206</sup>

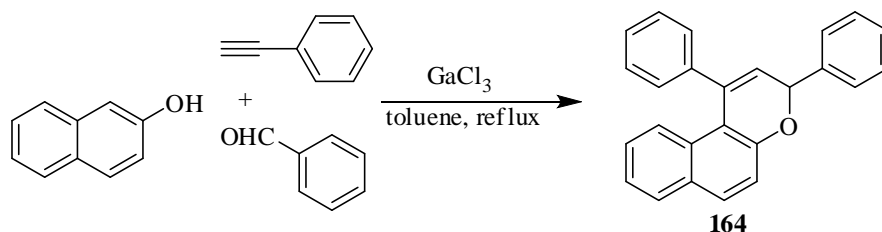

Scheme 132

Solvent free three component reaction of kojic acid, aldehyde and 1,3-dione affording dihydropyrano-[3,2-*b*]chromenedione derivative **165** using InCl<sub>3</sub> has been achieved. Domino Knoevenagel and hetero Diels-Alder reaction and subsequent dehydration lead to the products (Scheme 133).<sup>207</sup>

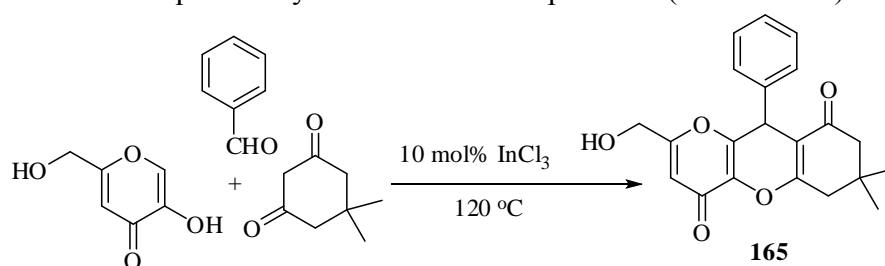

Scheme 133

An efficient, mild reaction for the synthesis of highly substituted pyran derivatives **166** is investigated in one-pot multicomponent condensation of an aldehyde, malononitrile, and diketoesters with recyclable heterogeneous strong basic Mg/La catalyst (Scheme 134).<sup>208</sup>

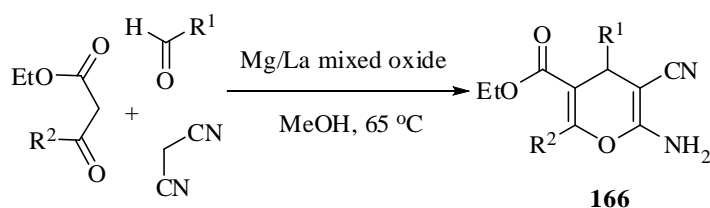
**Scheme 134**

An efficient and green methodology has been investigated<sup>209</sup> for the construction of pyran derivatives **167** through one-pot three component coupling reaction using nanostructure ZnO catalyst of an aldehyde, malononitrile and 1,3-diketone. It has also been developed a rearrangement reaction for the conversion of pyran derivatives to the 2-pyridone in aqueous media applying *p*-TsOH as catalyst (Scheme 135).

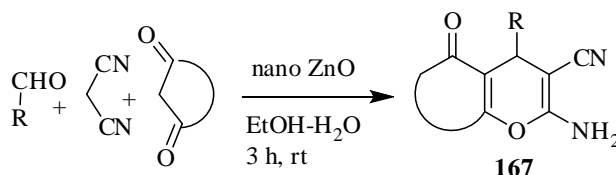
**Scheme 135**

Synthesis of nanocrystalline MgO and its catalytic efficacy and recyclability of the catalyst have been examined through the multicomponent synthesis of isatin, malononitrile, 1,3-diketone in equimolar ratio refluxing in water afforded spirooxindoles with fused tetrahydrochromene **168** in good yields (Scheme 136).<sup>210</sup>

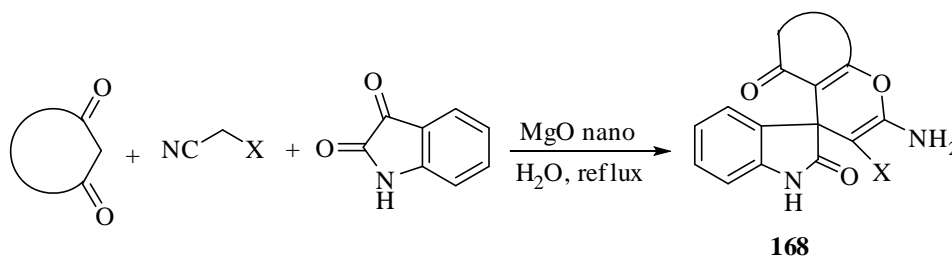
**Scheme 136**

One-pot three component reaction of isatin, malononitrile or cyanoacetic acid ester and phthalhydrazide catalyzed by NiCl<sub>2</sub> in an eco-friendly and cost effective solvent PEG 600 afforded pyrazolophthalazinyl spirooxindoles **169** in high to excellent yields has been described (Scheme 137).<sup>211</sup>

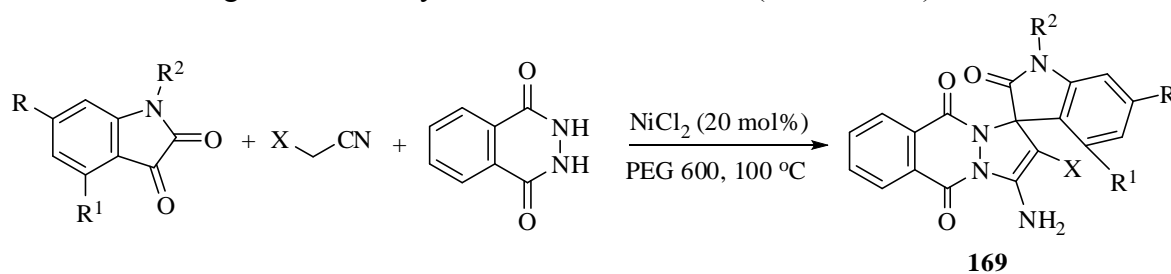
**Scheme 137**

One-pot four component coupling of aromatic amine, aldehyde,  $\beta$ -naphthol,  $\beta$ -oxodithioester and primary alcohol for the synthesis of 4*H*-[*f*]chromones **170** in the presence of  $\text{InCl}_3$  has recently been reported by Singh *et al.*<sup>212</sup> This four component coupling reaction proceeds via Knoevenagel condensation, Michael addition, intramolecular cyclization and *trans*-esterification in a highly chemoselective and regioselective manner affording the benzo[*f*]chromones in good yields (Scheme 138).

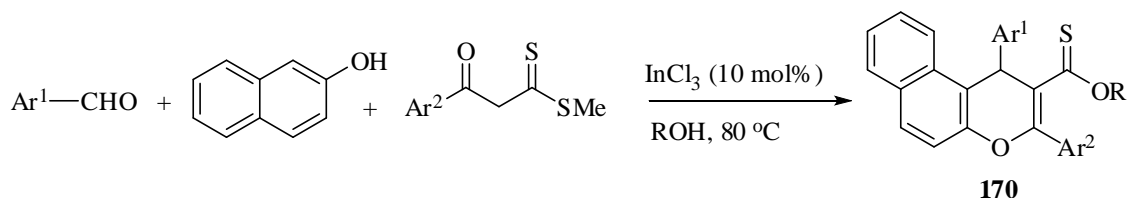

**Scheme 138**

The synthesis of 2-aminochromene **171** and indolyl chromene **172** by indium trichloride via three component reaction is developed. Salicylaldehyde, malononitrile and Hantzsch dihydropyridine ester in the presence of  $\text{InCl}_3$  produced 2-aminochromene. Hantzsch dihydropyridine ester here acts as hydride donor in the formation of 2-aminochromene. Interestingly under the same condition replacing Hantzsch dihydropyridine ester with indole provides indolyl chromene derivatives (Scheme 139).<sup>213</sup>

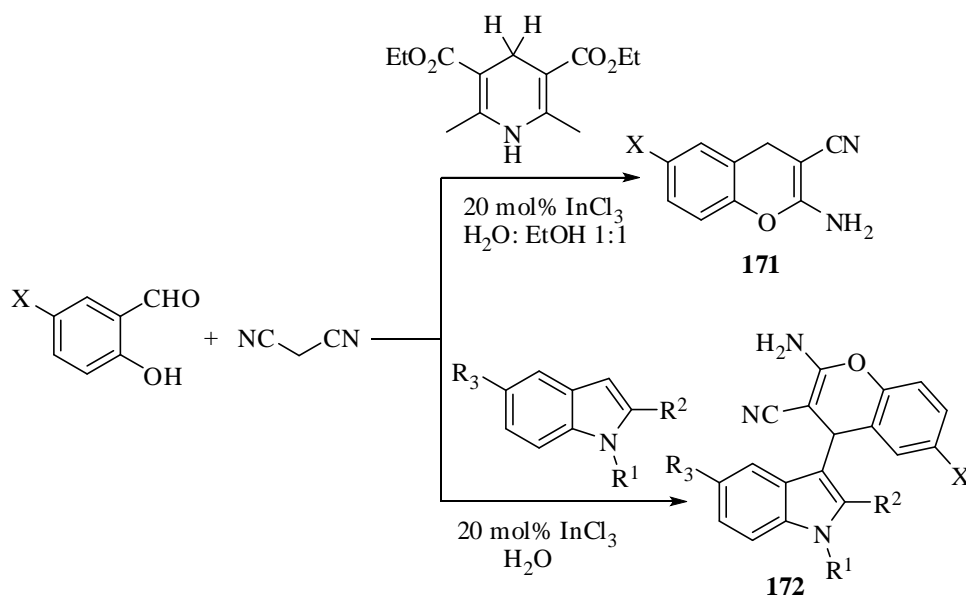

**Scheme 139**

An efficient three component coupling reaction involving Knoevenagel condensation, Micheal addition and then intramolecular cyclization in the presence of nano ZnO affording dihydropyranochromene **173** from aromatic aldehyde, malononitrile and 3-hydroxycoumarin has been demonstrated (Scheme 140).<sup>214</sup>

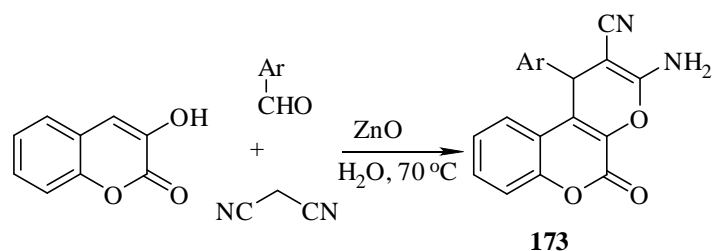
**Scheme 140**

An efficient, solvent free, eco-friendly, one-pot multicomponent reaction methodology for the synthesis of xanthene and anthracene derivatives **174** and **175** respectively in excellent yields by the reaction of aldehydes,  $\beta$ -naphthol and cyclic 1,3-dicarbonyl compounds in the presence of catalytic amount of  $\text{InCl}_3$  or  $\text{P}_2\text{O}_5$  is reported by Singh *et al.* (Scheme 141).<sup>215</sup> Other research groups also have synthesized benzoxanthene derivatives **174** in excellent yields by an one-pot three component condensation<sup>216</sup> reaction of dimedone, aldehyde and  $\beta$ -naphthol using metal nanoparticle supported acidic ionic liquid. Combination of  $\text{F}_3\text{O}_4$ -nano-support feature and soft imidazolium linkers makes the catalyst more free and soluble to the reaction system which facilitates effective condensation (Scheme 141).

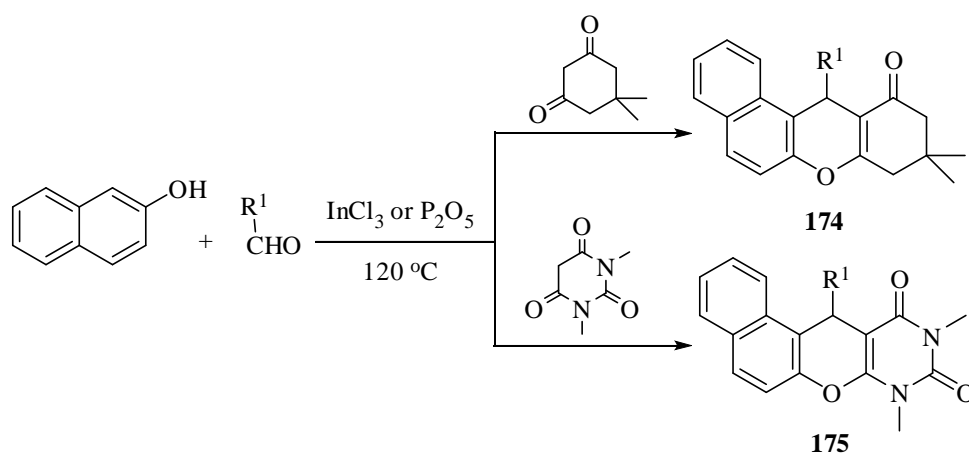
**Scheme 141**

Singh *et al.*<sup>217</sup> developed an efficient route for the synthesis of chromeno[2,3-*d*]pyrimidinone **176** and diazabenzo[*b*]fluorenone **177** using indium trichloride under solvent free condition. Mixture of aromatic aldehyde, cyclic-1,3-diketone and 1,3-dimethylbarbutaric acid in the presence of indium catalyst under neat condition resulting the formation of product. Aliphatic aldehydes, due to its tendency to undergo aldol condensation reaction as a side reaction affords mixtures of products lowering the yields of major product (Scheme 142).

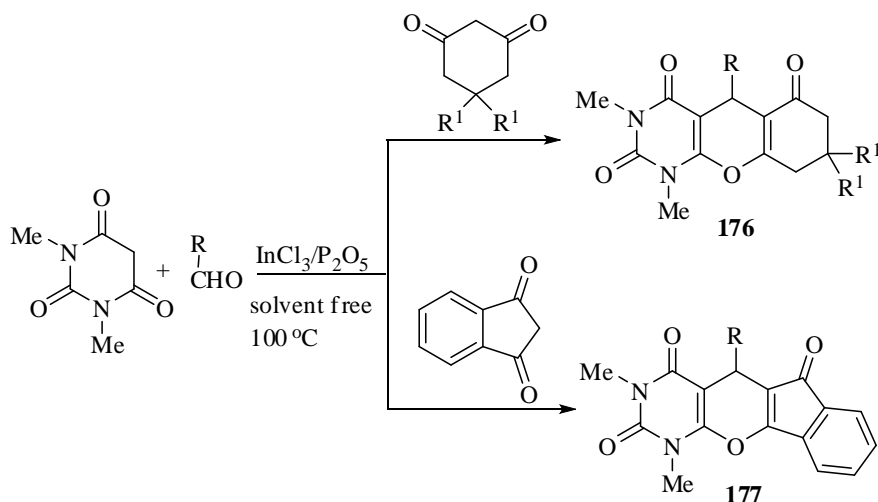

Scheme 142

Coupling of aldehyde, homoallylic alcohols and ammonium thiocyanates under three component reaction in the presence of  $In(OTf)_3$  produced 4-thiocyanotetrahydropyranes **178** via Prins-cyclization and thiocyanation sequence (Scheme 143).<sup>218</sup>

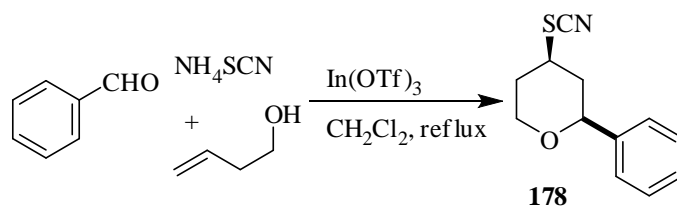

Scheme 143

An efficient three component strategy involves the generation of allyltin(IV) from allyl bromide in the presence of  $Pd(0)/SnX_2$  ( $X = Cl, Br$ ) in anhydrous DCM, then homoallyloxytin(IV) intermediate is formed from allyltin(IV) and an aldehyde, and finally coupled with an aldehyde, an aryl epoxide or an arene to afford tetrahydropyrans **179**, benzyl tetrahydropyrans **180** or 4,4-diarylbut-1-enes **181**, respectively (Scheme 144).<sup>219</sup>

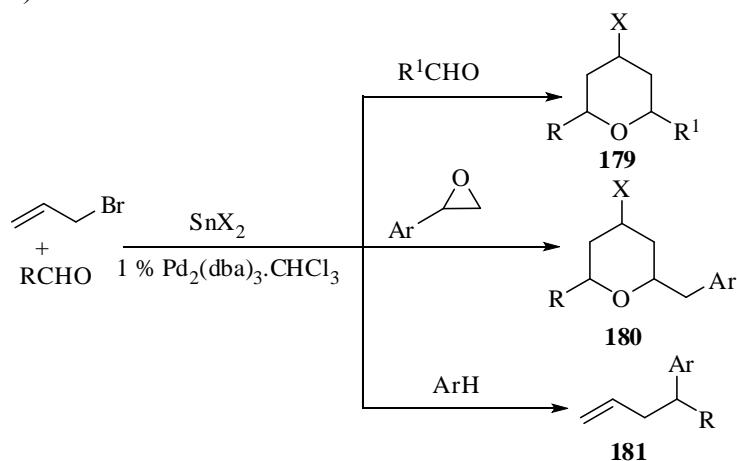

Scheme 144

The three component reaction between 1,3-diketone with terminal alkyne in the presence of carbon monoxide (200 *psi*) is effected in the presence of Pd(PPh<sub>3</sub>)<sub>2</sub>Cl<sub>2</sub> as catalyst and dppp as ligand in ionic liquid [bmim][Tf<sub>2</sub>N] to give the highly substituted endocyclic enol lactone **182** in moderate to good yield (Scheme 145).<sup>220</sup>

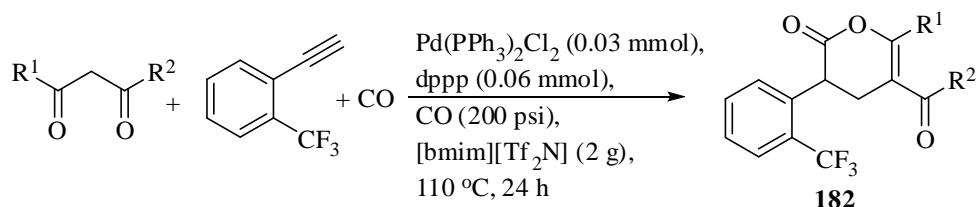

Scheme 145

Chromenes are the structural motifs frequently found in a number of natural products and biologically active molecules. An enantioselective one-pot three component reaction of salicylaldehyde, malononitrile, and indole for the synthesis of 2-amino-4-(indol-3-yl)-4*H*-chromenes **183** through a Knoevenagel/Pinner/Friedel-Crafts reaction sequence is catalyzed by Zn(II) complex (Scheme 146).<sup>221</sup>

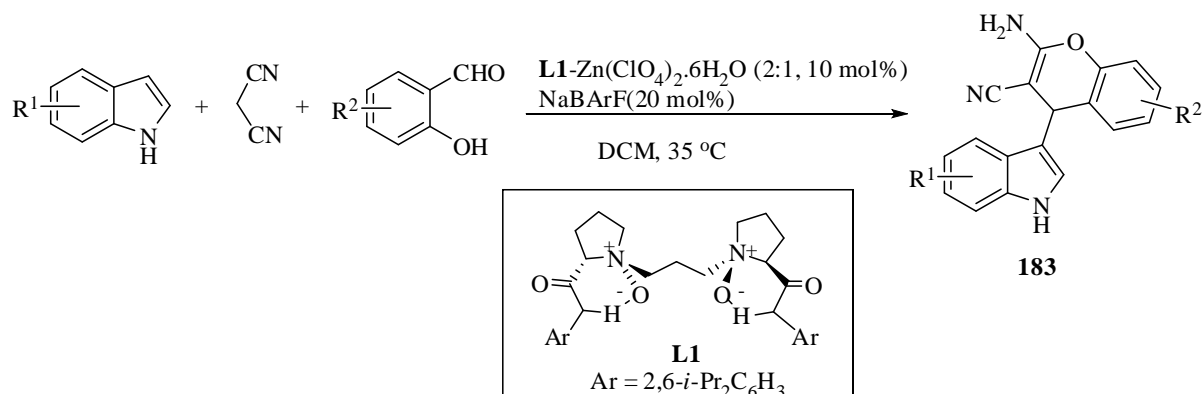

Scheme 146

Multicomponent reaction of 3,5-dimethoxyphenol, diethyl malonate and various aromatic aldehyde under room temperature in the presence of niobium pentachloride as catalyst providing coumarin derivatives **184** in good yields has been demonstrated.<sup>222</sup> Knoevenagel condensation, hydroarylation and intramolecular lactonization is responsible for the formation the product (Scheme 147).

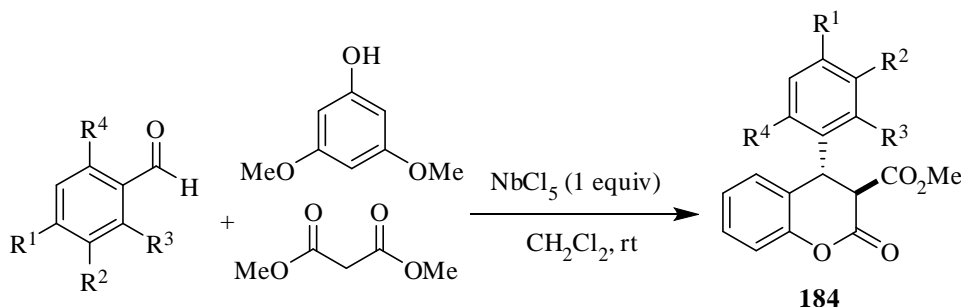

Scheme 147

Copper-catalyzed multicomponent reaction<sup>223</sup> of sugar-derived alkyne, tosyl azide and salicylaldehyde for the synthesis of glycosyl iminocoumarins **185** framework has been explored. This reaction undergoes initially copper-catalyzed click reaction between sugar-derived terminal alkyne and tosyl azide. Elimination of nitrogen ( $N_2$ ) of the intermediate forms ketimine, which on addition with phenolate of salicylaldehyde and subsequent intramolecular cyclization leads to the formation of products (Scheme 148).

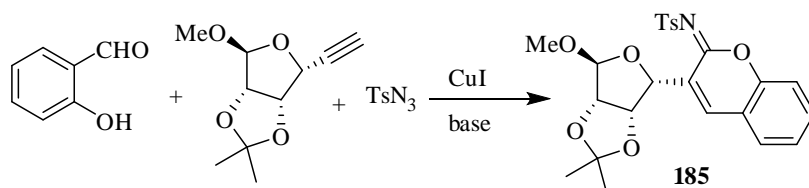

Scheme 148

Recently, a consecutive one-pot, three component coupling-addition-SNAr (CASNAR) sequence starting from aryl chlorides, alkynes, and sodium sulfide nonahydrate has been developed for the synthesis of 4*H*-thiochromen-4-one **186** in good yields (Scheme 149).<sup>224</sup>

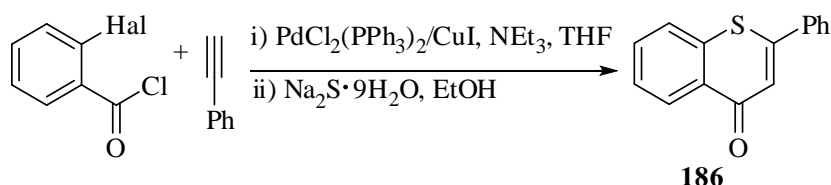

Scheme 149

## 3.2 HETEROCYCLES CONTAINING TWO HETEROATOMS

### 3.2.1 SYNTHESIS OF PYRIMIDINE AND DIHYDROPYRIMIDONE DERIVATIVES

A copper-catalyzed multicomponent reaction of sulfonyl azides, terminal alkynes, and  $\alpha,\beta$ -unsaturated imines has been developed to give a new class of pyrimidine derivative, *N*-sulfonyl-2-alkylidene-1,2,3,4-tetrahydropyrimidines **187** (Scheme 150).<sup>225</sup> In most of the cases, pyrimidines is isolated as the major product and in several cases, azetidines **188** is found as minor product with high *trans* selectivity from this three component reaction.

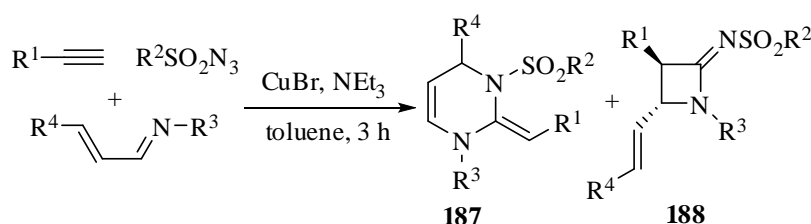

Scheme 150

ZnCl<sub>2</sub>-catalyzed three component reaction from structurally diverse enamines, triethyl orthoformate, and ammonium acetate leads to 4,5-disubstituted pyrimidine derivatives **189** in good yields through a single operation (Scheme 151).<sup>226</sup>

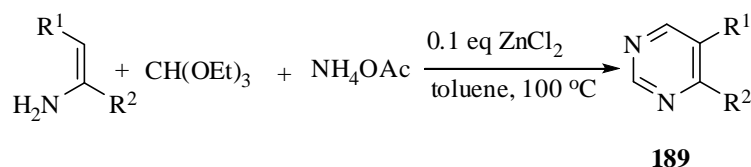

Scheme 151

AgI-catalyzed synthesis of polysubstituted pyrimidines **190** with high regioselectivity in good to excellent yields is achieved from electron-deficient alkynes, anilines, and formaldehyde (Scheme 152).<sup>227</sup>

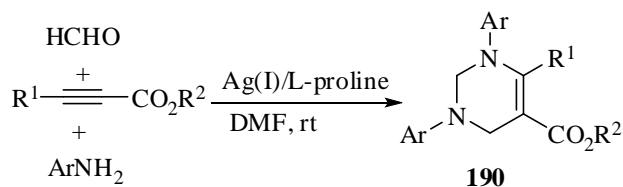

Scheme 152

Indium triflate-catalyzed<sup>228</sup> three component condensation reactions for the synthesis of spiro hexahydropyrimidine derivatives **191** from easily available starting materials like cyclohexanone, formaldehyde and aniline stirring in dichloromethane in room temperature has been described (Scheme 153).

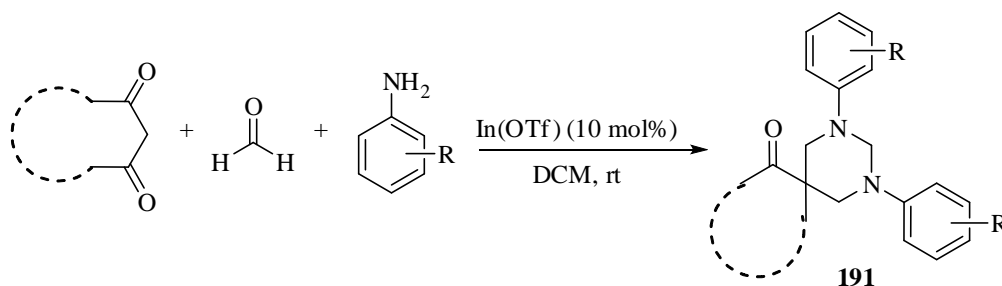

Scheme 153

Palladium-catalyzed iminoacylation by isocyanide insertion is an efficient but relatively unexplored method that offers significant advantages as compared to the well-known carbon monoxide insertions. By employing iminoacylation in palladium-catalyzed cascade reactions,<sup>229</sup> Orru *et al.* recently describes<sup>230</sup> a multicomponent reaction approach toward the synthesis of 4-aminophthalazin-1(2*H*)-ones **192** starting from *o*-bromobenzoates, isocyanides, and hydrazines in excellent yields (Scheme 154).

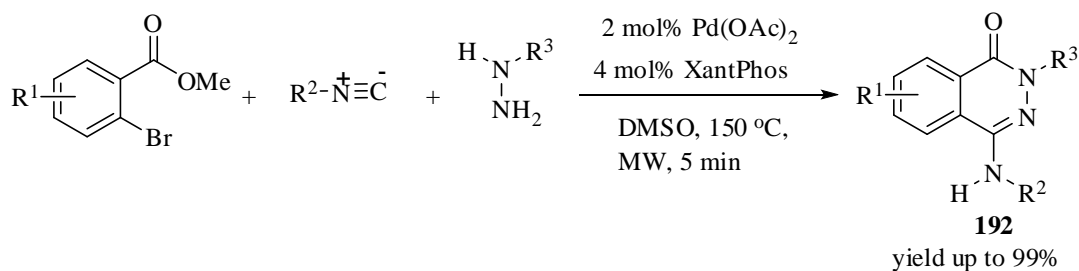

Scheme 154

The multicomponent reaction of aniline, formaldehyde and 1,3-diketone provides hexahydropyrimidines **194** using ferric chloride as catalyst in dichloromethane has been described.<sup>231</sup> The same methodology provides spiro analogous **193** when indane is used as 1,3-diketone. Similarly spiro substituted piperidine **195** were obtained instead of hexahydropyrimidines when dimedone is used as 1,3-dicarbonyl compound, due to its high reactivity (Scheme 155).

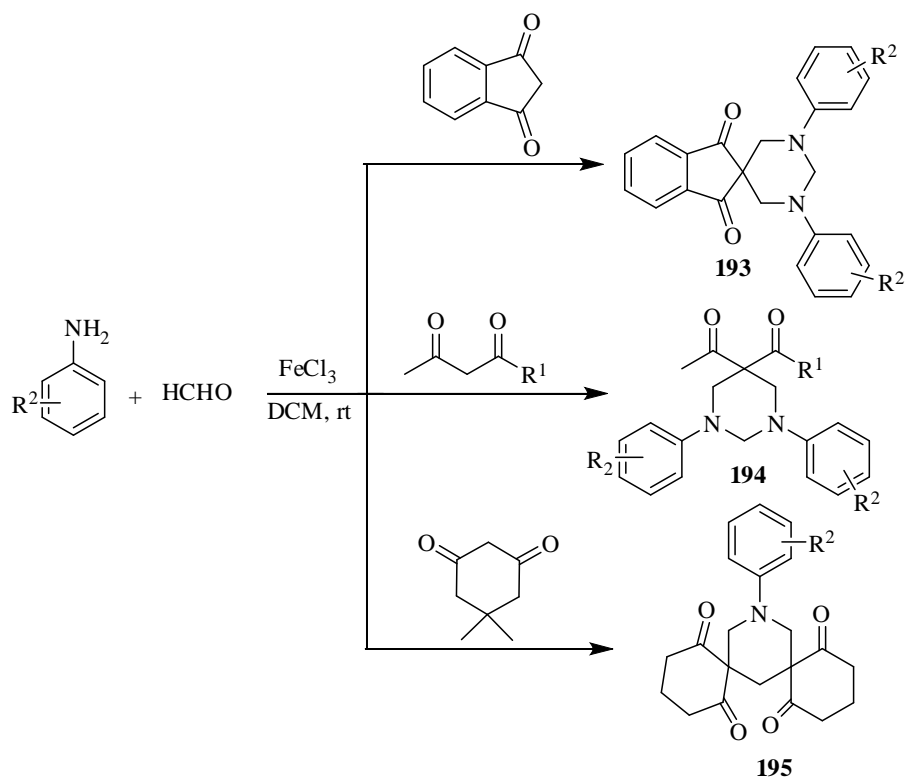

Scheme 155

Highly diverse multicomponent tandem reaction of acid chloride, terminal alkyne and ethyl-2-amino-1*H*-indole-3-carboxylate for the synthesis of pyrimidoindoles **196** in good to excellent yields has been reported.<sup>232</sup> The reaction involves sequential Sonogashira and [3+3] cyclocondensation reaction leading to the formation of product (Scheme 156).

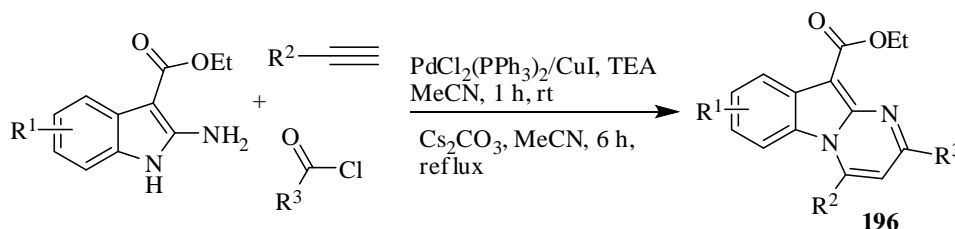

Scheme 156

Recently Biginelli multicomponent reaction for the synthesis of dihydropyrimidones **197** in excellent yield from ethyl acetoacetate, aldehyde and urea as component in the presence of copper triflate,<sup>233</sup> bismuth nitrate<sup>234</sup> and  $\text{LaCl}_3$ <sup>235</sup> as catalyst under microwave irradiation has been reported by different research groups. An efforts towards the synthesis of the same Biginelli dihydropyrimidine **197** from the same components using Zn(II) and Cd(II) metal-organic frameworks (MOFs) as a heterogeneous catalyst under solvent free condition has also been reported.<sup>236</sup> The metal-organic framework (MOFs) is useful, reusable and green catalyst making shorter reaction times for this synthesis (Scheme 157).

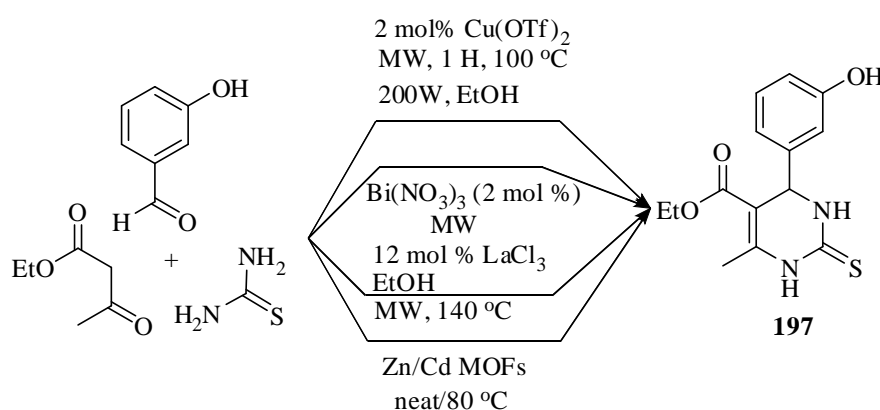

Scheme 157

Recently  $\text{SnCl}_2$ -catalyzed cyclocondensation of  $\beta$ -oxodithioesters with a variety of readily accessible aldehydes and urea (Scheme 158) has been reported for the synthesis of new dihydropyrimidinones **198** through<sup>237</sup> three-component Biginelli reaction.

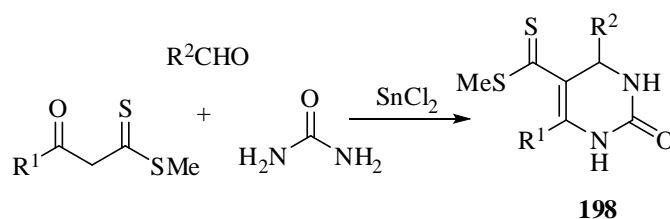

Scheme 158

Synthesis of polyfunctional 2,3-dihydropyrimidin-4-ones **199** utilizing  $\text{ZnCl}_2$  as catalyst has been described.<sup>238</sup> The Lewis acid  $\text{ZnCl}_2$  plays a dual role: promotes the isomerization of hydroaminated-intermediate and also facilitates further amidation of the isomerized product (Scheme 159).

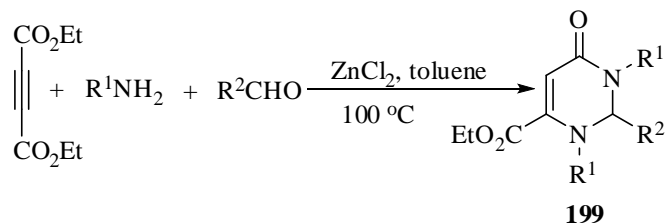

**Scheme 159**

The synthesis of 5:6 and 6:6 fused pyrimidine derivatives catalyzed by  $\text{KF}/\text{alumina}$  through a three component reaction has been reported in good yields (Scheme 160).<sup>239</sup>

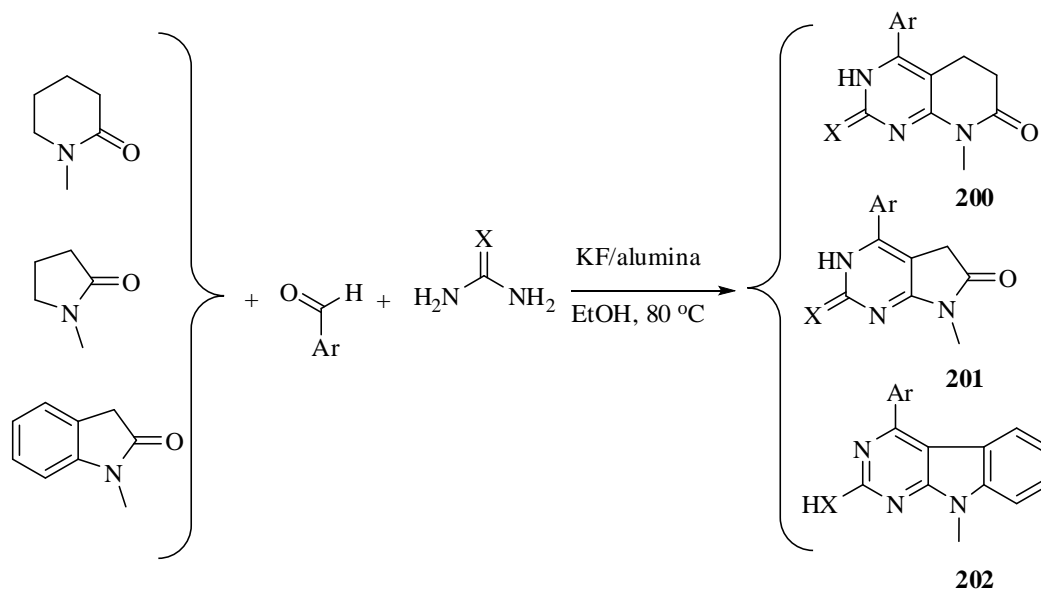

**Scheme 160**

A diastereoselective three component reaction using antimony trichloride for the synthesis of arylhexahydrofuropyrimidin-2-one **203** has been developed. Easily available starting material aldehyde, urea and dihydropyrane or dihydrofuran in the presence of mild and superior antimony trichloride as catalyst leads to the pyrimidine scaffolds in excellent yields (Scheme 161).<sup>240</sup>

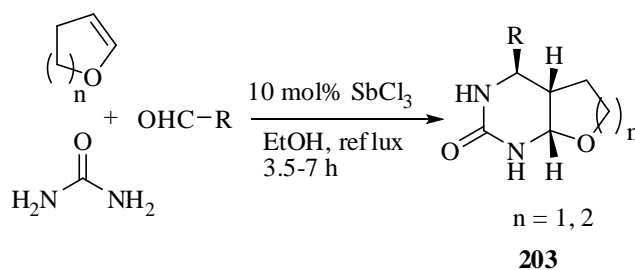

**Scheme 161**

### 3.2.2 SYNTHESIS OF QUINAZOLINONE, QUINOXALINE AND PROMAZINE DERIVATIVES

4(3*H*)-Quinazolinones have emerged as an important class of heterocycles that have attracted significant synthetic interest because of their pharmacological and therapeutic properties such as antibacterial, antifungal, antimalarial antihypertensive, anticonvulsant, analgesic, anti-inflammatory antiviral and anticancer activities.<sup>241-242</sup> 3-Aryl-6,8-dichloro-2*H*-1,3-benzoxazine-2,4(3*H*)-diones and 3-arylquinazoline-2,4(1*H*,3*H*)-diones have been used as antimycobacterial agents.<sup>243</sup> Several methods have been developed for their synthesis.<sup>244</sup>

Palladium-catalyzed three component intermolecular cyclocarbonylation of 2-iodoanilines and *N*-toluenesulfonyl-aldimines in the presence of carbon monoxide providing dihydroquinazolinone derivatives **204** has been investigated by Alper *et al.*<sup>245</sup> They also examined the effect of different ligands as well as solvent effects for this reaction and found that dppf as ligand and THF or toluene as solvent are superior in this regards (Scheme 162).

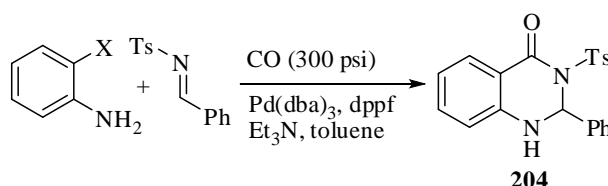

**Scheme 162**

Another palladium-catalyzed cyclocarbonylation of *o*-iodoanilines with imidoyl chlorides and carbon monoxide for the synthesis of substituted quinazolin-4(3*H*)-ones **205** has been developed in good to excellent yields by the same group. When equimolar amounts of *o*-iodoanilines and imidoyl chlorides are treated with palladium(II) acetate, triphenylphosphine and triethylamine in tetrahydrofuran under carbon monoxide (500 psi) at 140 °C, the corresponding quinazolinone derivatives are formed (Scheme 163).<sup>246</sup>

The reaction is believed to proceed via *in situ* formation of an amidine, followed by oxidative addition, carbon monoxide insertion, and intramolecular cyclization to give the substituted quinazolin-4(3*H*)-ones.

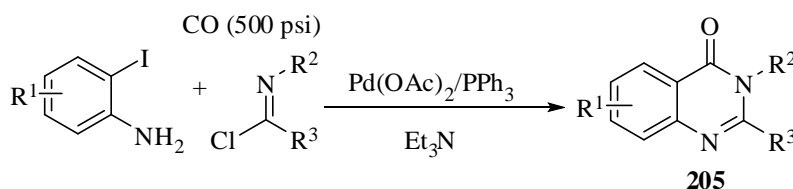

**Scheme 163**

The selective synthesis of 2,3-dihydroquinazolin-4(1*H*)-ones **206** and quinazolin-4(3*H*)-ones **207** using Ga(OTf)<sub>3</sub> as a reusable catalyst in ethanol involving isatoic anhydride, ammonium acetate or amines and aldehydes in one-pot have been described (Scheme 164).<sup>247</sup>

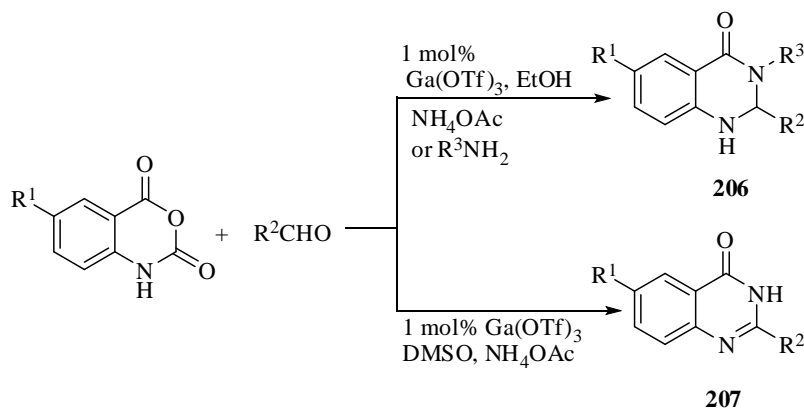

Scheme 164

Palladium acetate and cuprous iodide assisted sequential multicomponent cascade synthesis of quinazolinones **208** in moderate to good yields from tosyl azide, 2-iodoaniline, phenylacetylene and carbon monoxide is reported.<sup>248</sup> This sequential process includes the copper-catalyzed three component reaction and palladium-catalyzed carbonylation (Scheme 165).

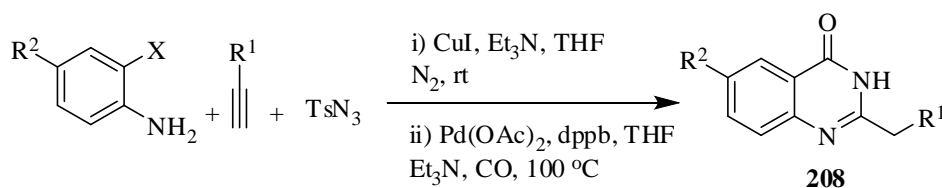

Scheme 165

An efficient and convenient synthesis for the preparation of 1'*H*-spiro[indoline-3,2'-quinazoline]-2,4'(3'*H*)-diones **209** through a three component cyclocondensation employing isatoic anhydride, isatins and amines using the inexpensive, non-toxic and easily available  $\text{KAl(SO}_4)_2 \cdot 12\text{H}_2\text{O}$  (alum) as catalyst has been described (Scheme 166).<sup>249</sup>

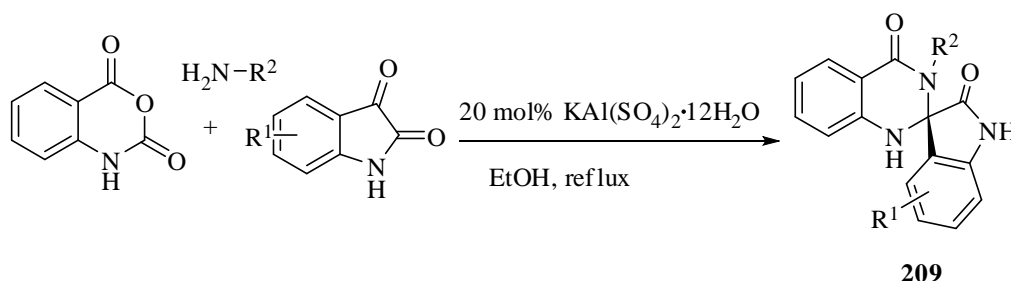

Scheme 166

The synthesis of *N*-cyclohexyl-3-arylquinoxaline-2-amines **210** through the reaction of *o*-phenylenediamine, cyclohexyl isocyanide and an aromatic aldehyde utilizing ferric perchlorate is reported (Scheme 167).<sup>250</sup>

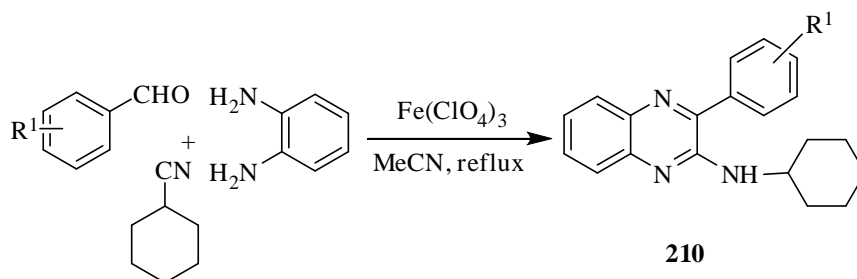

Scheme 167

Three component reaction using 2-(methylamino)phenyl-4-methylbenzenesulfonate, paraformaldehyde and phenylacetylene in the presence of CuCl and KOH provides 1,4-benzoxazine derivatives **211**. The process is completely regioselective and stereoselective resulting (*Z*)-isomer (Scheme 168).<sup>251</sup>

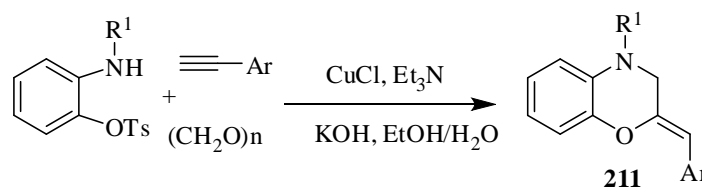

Scheme 168

Palladium-catalyzed under microwave irradiation three component approach to promazine **212** with the formation of C-S bond from thiophenols and aryl iodides and C-N bond from amines and aryl bromides in an one-pot reaction has been reported.<sup>252</sup> The transformation may also be carried out by conventional heating with comparable yields (Scheme 169).

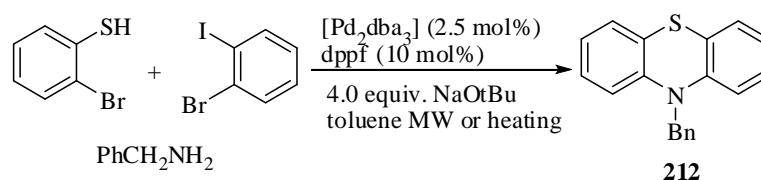

Scheme 169

Smiles rearrangement under microwave irradiation has been investigated<sup>253</sup> for one-pot synthesis of benzo[*b*][1,4]thiazin-3(4*H*)-one derivatives **213** involving 2-chlorobenzothiols, chloroacetyl chloride and primary amines as components (Scheme 170).

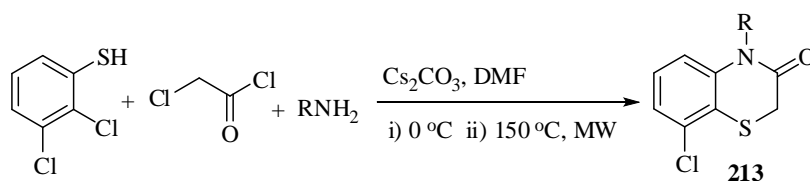

Scheme 170

### 3.3 HETEROCYCLES CONTAINING THREE HETEROATOMS

One-pot multicomponent synthesis of triazinane diones **214** from phosphonates, nitriles, aldehydes, and isocyanates have been reported (Scheme 171). Aldehydes with (hetero) aromatic and aliphatic substituents and isocyanate components with benzylic and aromatic substituents is suitable for the reaction.<sup>254</sup>

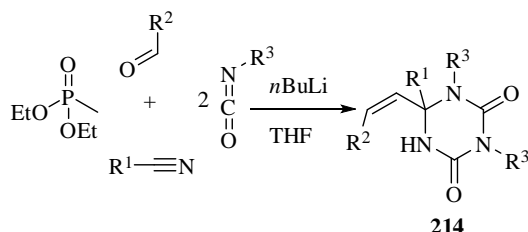

**Scheme 171**

Synthesis of 2-aryl-1,3,2-aryldioxaborins **215** from phenols, aldehydes, and phenylboronic acid using  $ZrCl_4$  as catalyst is investigated (Scheme 172).<sup>255</sup> This reaction is assumed to proceed via [3,3]-sigmatropic rearrangement pathway which is well documented in the literature.<sup>256</sup>

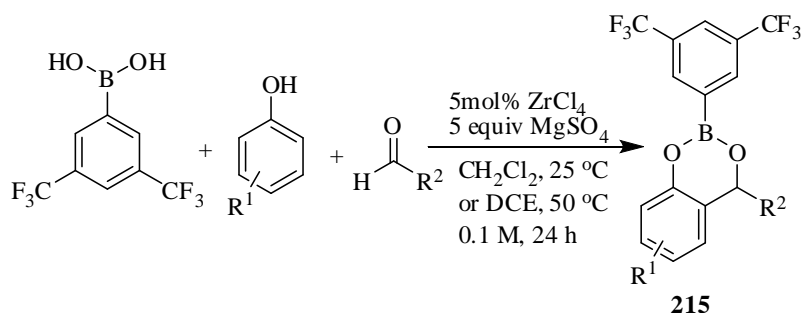

**Scheme 172**

#### 4. CONSTRUCTION OF SEVEN-MEMBERED HETEROCYCLES

Synthesis of various furoazepine derivatives from imidazopyridine carbenes, different heterocyclic *o*-dialdehydes and activated alkynes is developed.<sup>257</sup> The formation of products undergoes the followings steps: first imidazopyridine carbenes and aromatic dialdehyde form dipolar intermediates via nucleophilic addition which undergo [3+2] cycloaddition with electron-deficient alkynes followed by aromatization and further intramolecular nucleophilic addition to aldehyde give the products in good yields (Scheme 173).

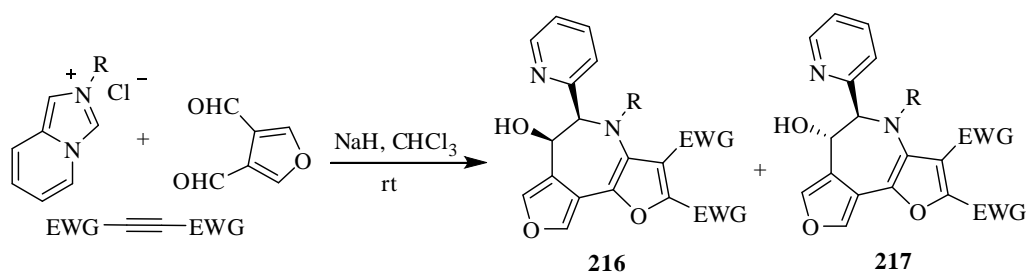

**Scheme 173**

Diazepines<sup>258</sup> have been the object of intense investigation in medicinal chemistry, because of their remarkable central nervous system depressant activity and more recently, the area of biological interest of 1,5-benzodiazepines have been extended to antibiotics and various diseases.<sup>259</sup> Recently one-pot multicomponent synthesis of diazepine derivatives **218** from a 1,2-diamine, a linear or cyclic ketone, and an isocyanide in the presence of a catalytic amount of silica supported iron oxide ( $\text{Fe}_3\text{O}_4/\text{SiO}_2$ ) nanoparticles at ambient temperature has been reported.<sup>260</sup> Metal nanoparticles (MNPs), especially supported magnetic metal nanoparticles (S-MMNPs), have emerged as a new class of nanocatalyst (Scheme 174).

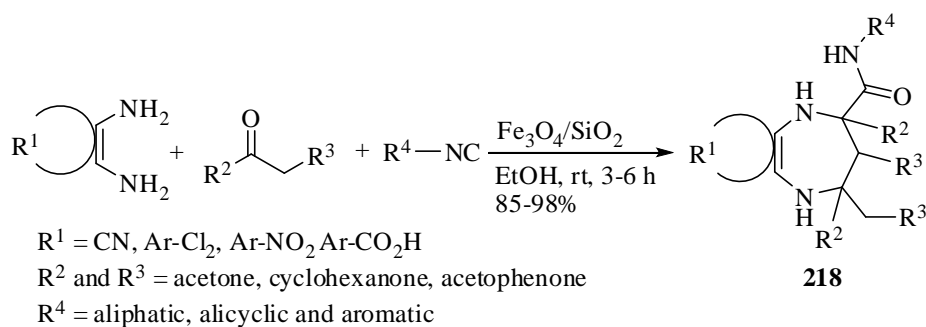

Scheme 174

*o*-Phenylenediamines, with *in situ* generated alkynones from acyl chloride and alkynes produced pharmacologically interesting seven-membered heterocycles 1,5-benzodiazepines **219** via coupling addition-cyclocondensation sequence in the presence of palladium and copper as combined catalyst (Scheme 175).<sup>261</sup>

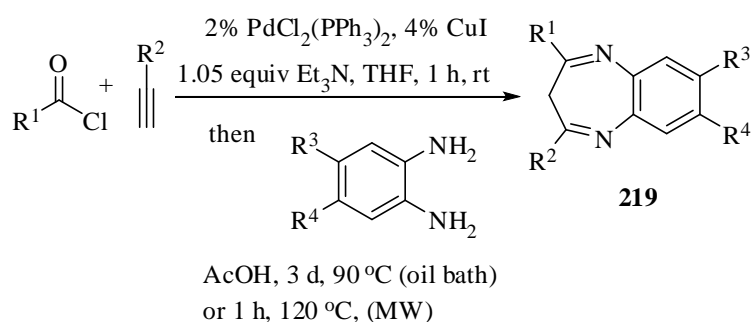

Scheme 175

One-pot synthesis of benzodiazepinone derivatives **220** by Er(III) triflate is reported.<sup>262</sup> Condensation reaction of 1,2-phenylenediamine and dimedone followed by cyclization with aliphatic or aromatic acyl chloride in the same reaction pot stirring at room temperature afforded the benzodiazepinone derivative in good yields (Scheme 176).

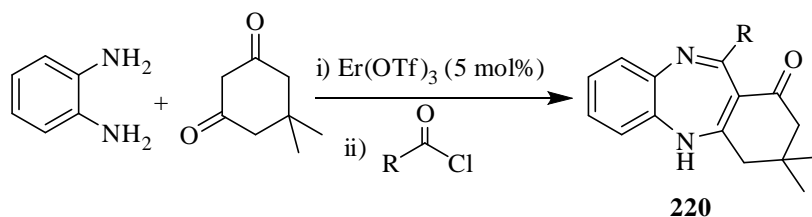

Scheme 176

A novel multicomponent tandem imino-pinacol coupling-aza-Michael reaction have developed<sup>263</sup> for the synthesis of polysubstituted monocyclic 1,4-diazepine derivatives **221** from  $\alpha,\beta$ -unsaturated ketone, aromatic aldehyde and aniline in the presence of  $\text{Zn}/\text{InCl}_3$  as catalyst under aqueous medium. The method is eco-compatible, efficient, high yielding and atom economical (Scheme 177).

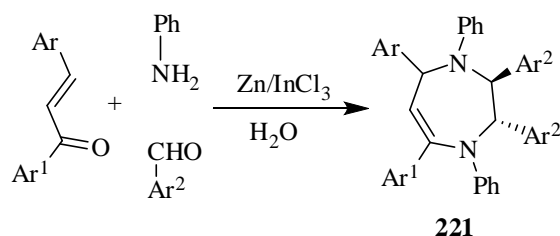

Scheme 177

An isocyanide-based multicomponent reaction for the synthesis of polysubstituted 1,4-benzodiazepin-3-ones **222** and **223** (Scheme 178)<sup>264</sup> using a reducing agent,  $\text{Fe}^0/\text{NH}_4\text{Cl}$ , in protic solvents, under controlled microwave irradiation, proceeds through an one-pot, two-step process. Interestingly, *o*-nitrobenzaldehyde and *o*-nitrobenzylamine not only act as bifunctional substrates, but also selectively direct a substitution pattern for benzodiazepin-3-ones of type **222** and **223**.

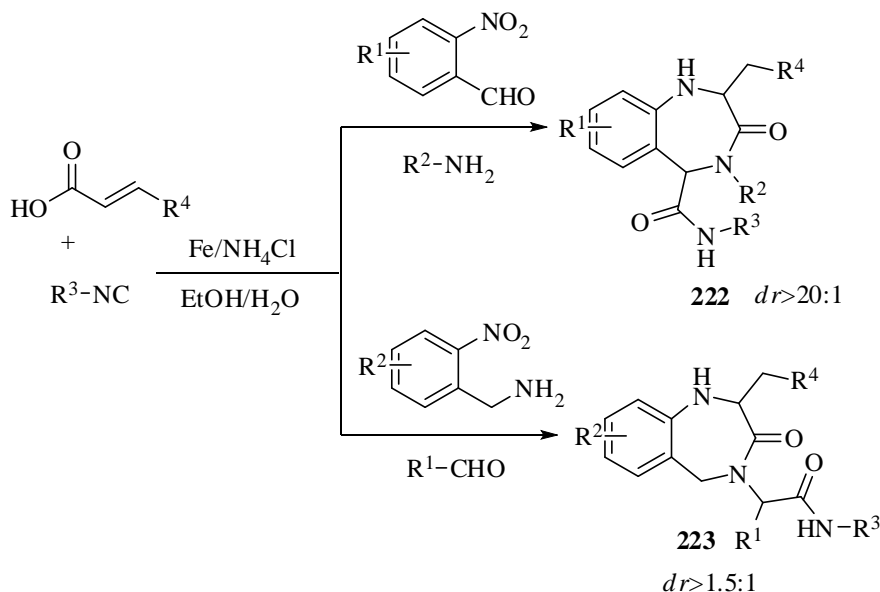

Scheme 178

Microwave-assisted approach for the formation of pyrimido-oxazepine analoges **224** is developed. Mixture of dichloropyrimidine, secondary or primary aliphatic amine and salicylaldehyde in the presence of cesium carbonate ( $\text{Cs}_2\text{CO}_3$ ) under microwave irradiation followed by reduction of the subsequent product with  $\text{NaBH}_4$  at room temperature in the same reaction pot provides the expected product (Scheme 179). It is interesting that arylamine produces lower yield under this study.<sup>265</sup>

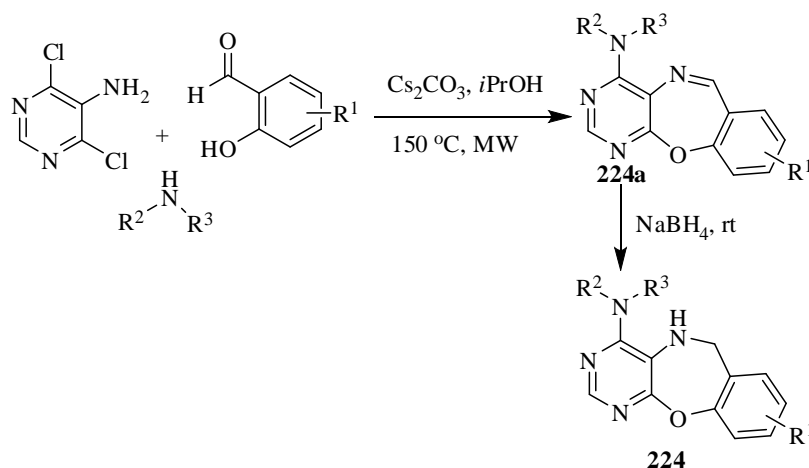

Scheme 179

## 5. MISCELLANEOUS

Solvent free multicomponent reaction catalyzed by copper salt towards the synthesis of *N*-sulfonylazetidone-2-imine **225** is described.<sup>266</sup> Multicomponent reaction of sulfonyl azides, terminal alkyne and carbodiimides in the presence of copper oxide leads to the formation of the product **225** (Scheme 180).

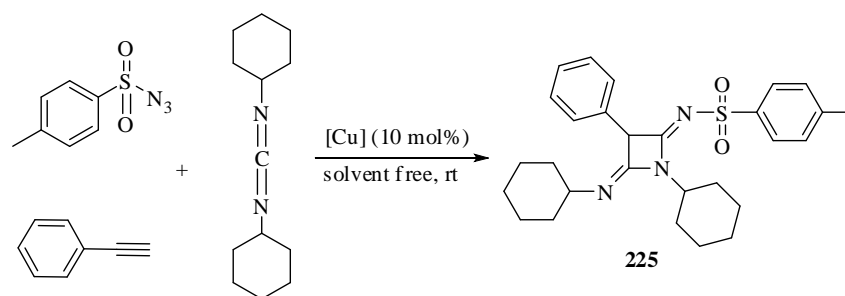

Scheme 180

A new and simple synthetic protocol for the construction of spirocyclic quinoline derivatives **226** through one-pot three component coupling reaction of an alkynol derivative, an aldehyde, and an aromatic amine has been developed (Scheme 181).<sup>267</sup> In this Povarov synthesis, both reactive species, enol ether and the *N*-arylaldehyde, are catalytically preformed *in situ* prior to the reaction.

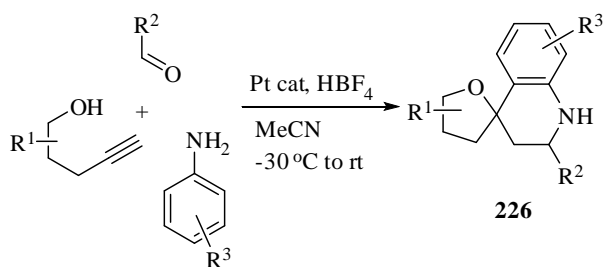

Scheme 181

A multicomponent reaction is carried out by the treatment of pent-4-yn-1-ols, salicylaldehydes and alkoxyethanes by  $[\text{Pd}(\text{MeCN})_4](\text{BF}_4)_2$  in acetonitrile at room temperature to provide the oxygen-substituted chroman spiroacetal **227** in high yields (Scheme 182).<sup>268</sup>

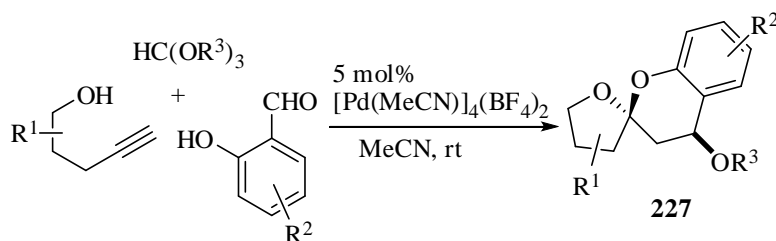

Scheme 182

Copper-catalyzed domino three component coupling reaction under microwave irradiation for the synthesis of indole-fused benzo-1,4-diazepines **228** from *N*-mesyl-2-ethynylaniline and *o*-bromobenzylamines has been reported by Ohta *et al.* (Scheme 183).<sup>269</sup>

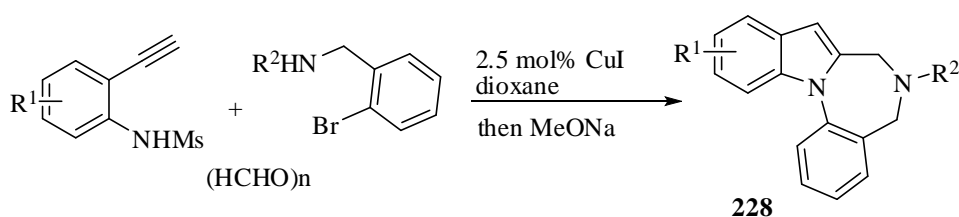

Scheme 183

Copper-catalyzed<sup>270</sup> domino three component coupling-cyclization is developed by Ohta group involving ethynylaniline, paraformaldehyde, an amino ester in dioxane under microwave irradiation to produce the indole intermediate which on treatment with MsOH at 80 °C for 30 min furnished 4-oxotetrahydro- $\beta$ -carbolines **229** (Scheme 184).

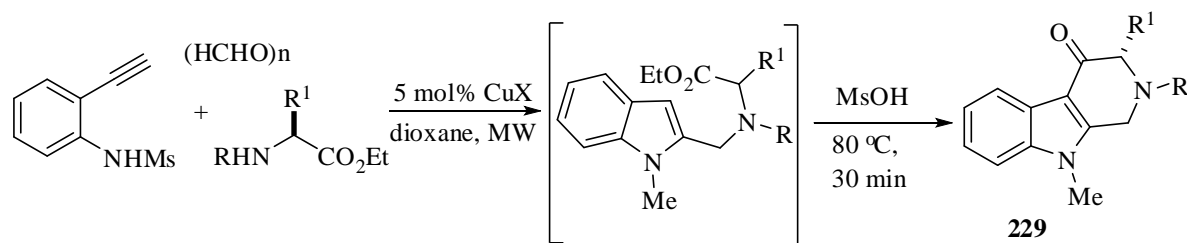

Scheme 184

A new copper-catalyzed synthesis of 3-(aminomethyl)isoquinoline-fused polycyclic compounds **230** through four component coupling, cyclization, and oxidation, is described by the same group (Scheme 185).<sup>271</sup> The Mannich-type reaction of 2-ethynylbenzaldehyde with paraformaldehyde and a secondary amine followed by the treatment with a diamine component in the presence of CuCl afforded tricyclic isoquinolines. In this reaction, CuCl showed effective catalytic activity under an oxygen atmosphere to afford the corresponding products in moderate to good yields.

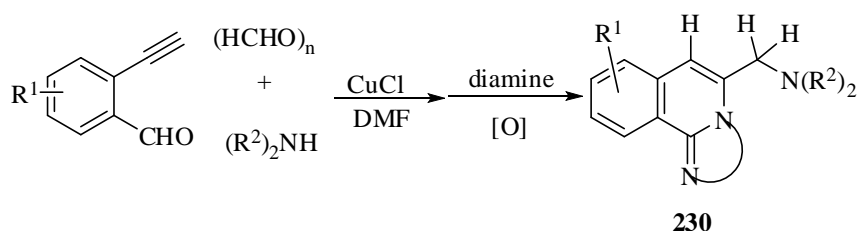

Scheme 185

Palladium-catalyzed couplings of *N,N*-di(*o*-iodophenyl)carbodiimides with different alkyl or aryl amines under carbon monoxide providing quinazolino[3,2-*a*]quinazolinones **231**, in a single operation has been reported by Alper *et al.*<sup>272</sup> The reaction is not dependent on the electronic nature of the substituents of the aryl moiety. Increasing the bulkiness of the R<sup>3</sup> group decreased the yield of the tetracyclic product (Scheme 186).

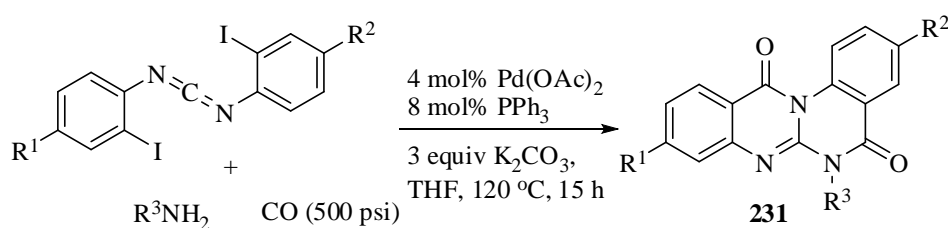

Scheme 186

An easy route to benzindolizine derivatives **232** involving the cycloaddition of azadienes with a silyl enol ether followed by a palladium(0)-catalyzed Heck coupling reaction has been developed. The *in situ*

generated azadienes (X = H, Me, Cl) undergoes cycloaddition reactions with ethyl 3-trimethylsiloxy-2-butenate followed by intramolecular Heck coupling reaction using a catalytic amount of palladium(II) acetate in anhydrous toluene in the presence of a slight excess of triethylamine as a base (Scheme 187).<sup>273</sup>

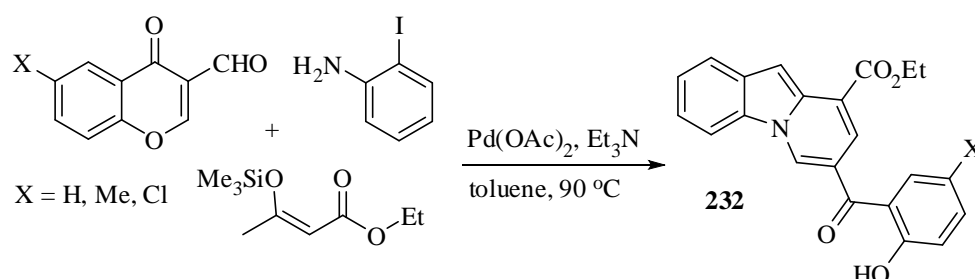

Scheme 187

An efficient, simple and novel one-pot four component reaction for the synthesis<sup>274</sup> of pyranopyrazol-6-one derivatives **233** refluxing in aqueous media in the presence of Ba(OH)<sub>2</sub> as readily available, inexpensive and effective catalyst from hydrazine hydrate, ethyl acetoacetate, aromatic aldehyde and Meldrum's acid has been reported (Scheme 188).

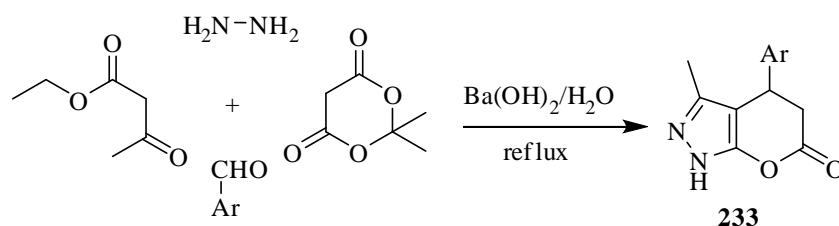

Scheme 188

Multicomponent reaction of ethyl acetoacetate, hydrazine hydrate, malononitrile and aldehyde to produce 6-amino-4-alkyl/aryl-3-methyl-2,4-dihydropyrano[2,3-*c*]pyrazole-5-carbonitrile **234** using expedient and recyclable  $\gamma$ -alumina as catalyst is described recently.<sup>275</sup> It is also reported the comparative catalytic efficacy of  $\gamma$ -alumina, basic alumina and KF-alumina. Among these three catalysts,  $\gamma$ -alumina proved to be the most effective for this multicomponent reaction (Scheme 189).

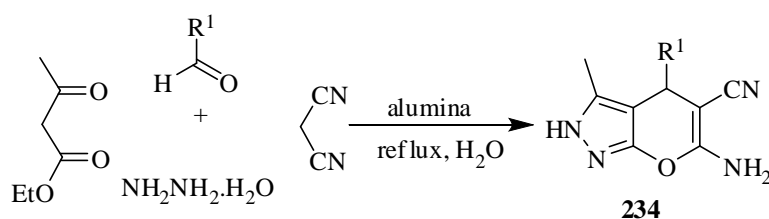

Scheme 189

Silver(I) triflate and nickel perchlorate hexahydrate-catalyzed three component reactions for the synthesis of tetrahydropyridazinoisoquinoline derivative **235** of 2-alkynylbenzaldehydes, sulfonylhydrazide and dimethyl cyclopropane has been reported where 6-*endo* cyclization and [3+3] cycloaddition is responsible for the formation of product (Scheme 190).<sup>276</sup>

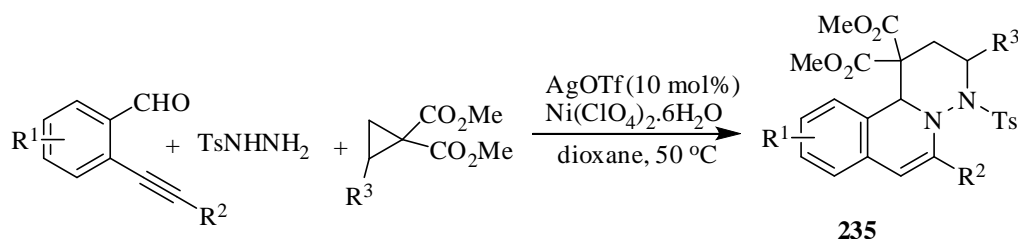

Scheme 190

A novel four component reactions for the construction of tetracyclic aza-analogs of nuevamine **236** from aldehyde, amine, isonitrile compound and maleic anhydride by free radical cyclization with tributyltin hydride and scandium triflate under microwave irradiation is reported (Scheme 191).<sup>277</sup>

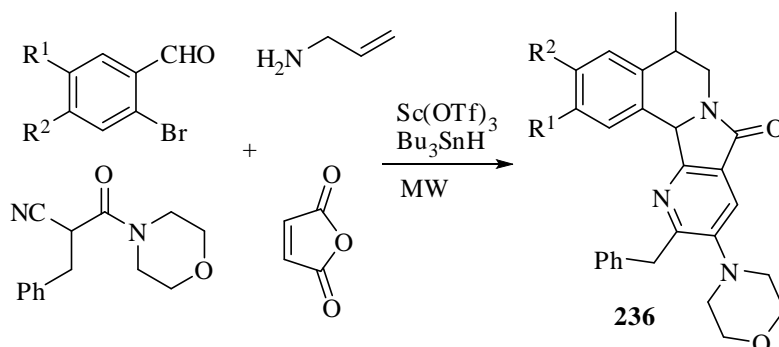

Scheme 191

An array of naphthoxazinone derivatives **237** is synthesized with copper nanoparticle from the mixture of aldehyde, urea and 2-naphthol in PEG-400 at room temperature.<sup>278</sup> In case of *N*-methylurea, the yield of the product reduces whereas in case of *N,N*-dimethylurea, both  $\alpha$ -naphthol and naphthalen-2-thiol are failed to produce any product. In mechanistic rationalization, at initial event aldehyde and urea condensed to form reactive acylimine. Subsequently, the acylimine undergoes a cyclization with 2-naphthol to afford naphthoxazinones (Scheme 192).

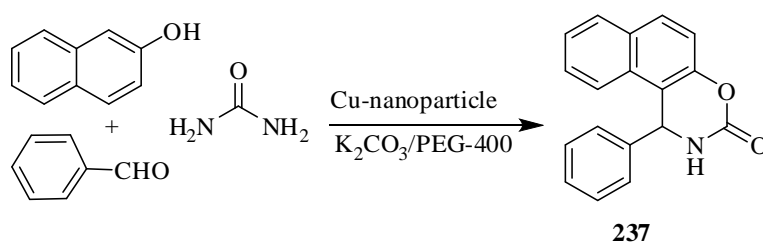

Scheme 192

Environmentally benign one-pot four component condensation reaction of phthalic anhydride, hydrazinium hydroxide, aromatic aldehyde and dimedone in the presence of  $\text{Ce}(\text{SO}_4)_2 \cdot 4\text{H}_2\text{O}$  as eco-friendly catalyst for the formation of indazolophthalazine trione **238** under solvent free condition has been reported. The mechanistic rationalization of this multicomponent reaction is responsible for initially formation of phthalhydrazide from nucleophilic addition of hydrazinium hydroxide to phthalic anhydride followed by dehydration and subsequent Michael type addition reaction and cyclization of phthalhydrazide and heterodiene which is formed by Knoevenagel condensation between dimedone and aldehyde affording the product (Scheme 193).<sup>279</sup>

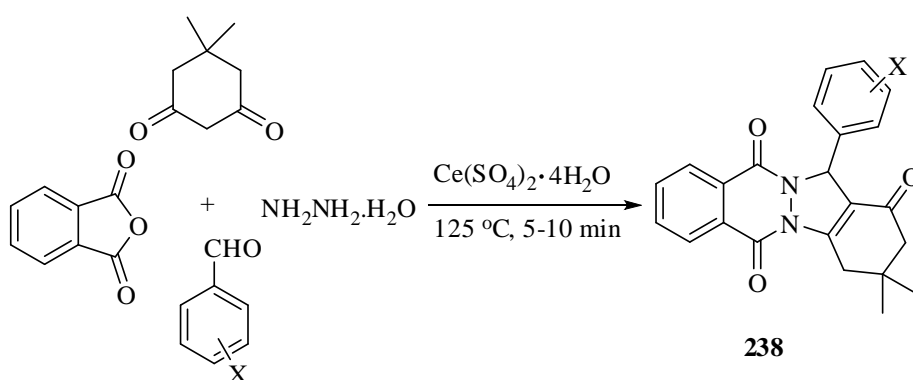

**Scheme 193**

One-pot four component reaction<sup>280</sup> of phthalimide, hydrazine hydrate, aromatic aldehyde and malononitrile or ethyl cyanoacetate in refluxing ethanol has been described using  $\text{NiCl}_2 \cdot 6\text{H}_2\text{O}$  as effective and inexpensive catalyst for the synthesis pyrazolophthalazinedione **239** in good yield (Scheme 194).

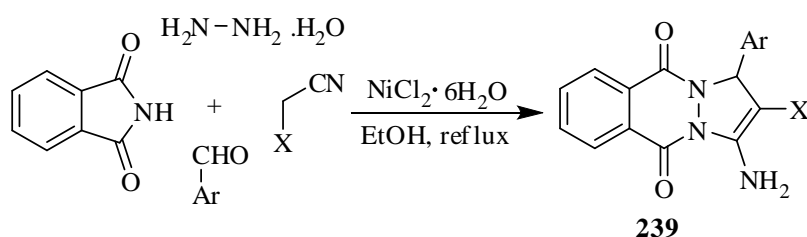

**Scheme 194**

Three component reaction of  $\delta$ -hydroxy- $\alpha,\beta$ -unsaturated aldehyde (perlin aldehyde), 1,3-diketone and aniline in dichloromethane using indium(III) chloride as catalyst at  $-10\text{ }^\circ\text{C}$  is described.<sup>281</sup> This provides the sugar annulated *N*-aryl-tetrahydropyridine derivatives **240** in good yield (Scheme 195).

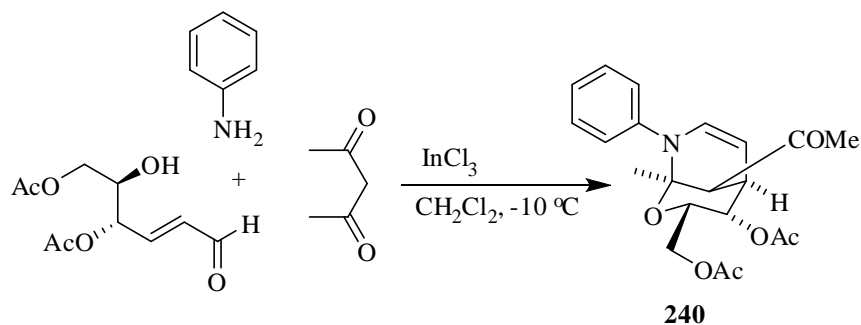

Scheme 195

Transition metal-catalyzed reactions of functionalized allenes have become one of the most important tools for the synthesis of some biologically important systems especially the medium-sized heterocyclic system. Palladium-catalyzed carbopalladation of allenes may afford the  $\pi$ -allylic palladium species which would react with a nucleophile to form the allylation product. A three component Pd(0)-catalyzed highly chemo- and regioselective cyclization reaction for the synthesis of ten-membered heterocycles **241** with two stereodefined C-C bonds from 1,5-bisallenes, organic halides and primary amines has been reported (Scheme 196).<sup>282</sup>

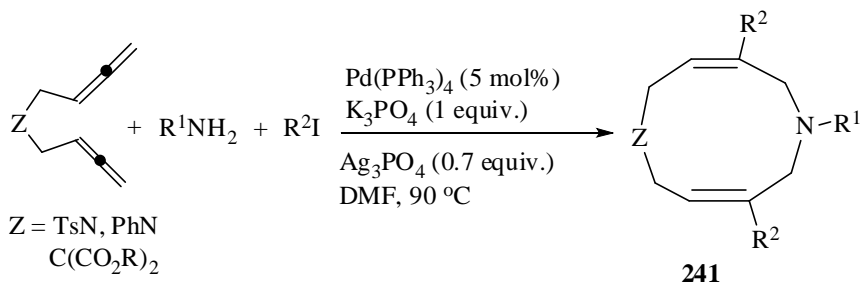

Scheme 196

One-pot three component reaction combining a set of acyclic substrates/reagents of 1,2-diaza 1,3-dienes, primary amines, and isothiocyanates in a different order of addition under the same reaction conditions, a robust chemo-/regioselective approach to heterocyclic skeletal diversity is achieved. The protocols afford selectively substituted 1,3,5-trisubstituted 2-thiohydantoin or 2-iminothiazolidin-4-ones **242** and **243** bearing a diversity at the 5-position of the heterorings (Scheme 197).<sup>283</sup>

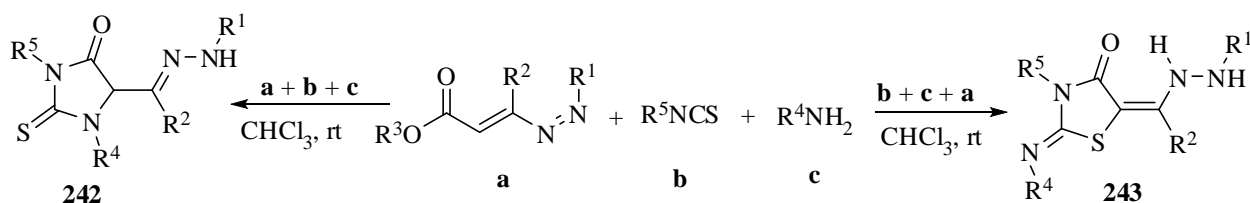

Scheme 197

Salicylaldehyde, malononitrile and amine in the presence of catalytic amount of  $\text{LiClO}_4$  afford benzopyranopyrimidines **244** via pseudo four component reactions. It is assumed that the reaction involved the Knoevenagel condensation between salicylaldehyde and malononitrile followed by subsequent Pinner reaction to afford an intermediate. Cyano group of that intermediate is then attacked by the amine, followed by cyclization with another mole of salicylaldehyde producing the final product (Scheme 198).<sup>284</sup>

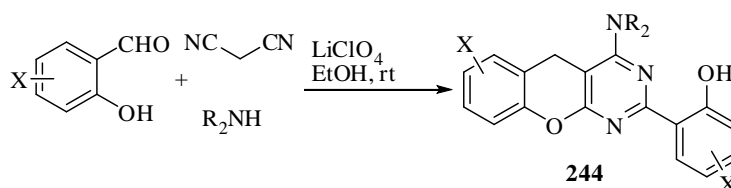

**Scheme 198**

## 6. CONCLUSION

Heterocycles are found in many natural products, pharmaceuticals, organic materials, and in numerous functional molecules. Therefore, the ongoing interest for developing new versatile and efficient syntheses of heterocycles has always been a challenge in the synthetic community. Heterocycles are especially important in chemical and pharmaceutical industries. The traditional and conventional methodologies mostly used for the synthesis of these heterocycles, are reliable and robust and proceed generally at low cost, but these methodologies suffered with waste byproducts and harsh reaction conditions. In this regards, multicomponent reactions (MCRs) minimize such waste and are in general environmentally benign. Heterocycles having a complicated structure with many labile functional groups can be synthesized often from rather simple easy accessible starting materials through sequential catalytic processes in one-step.

In the past decade developments in the multicomponent reactions (MCRs) have greatly increased. More development in the area of multicomponent reactions (MCRs) in near upcoming research is required for the synthesis of a variety of heterocyclic compounds. The ability to perform tandem reactions to construct complex heterocyclic scaffolds makes the multicomponent reactions (MCRs) a potentially powerful synthetic tool. We hope that this review will be useful not only for synthetic organic chemists but also for heterocyclic and natural product synthetic chemists.

## 7. ACKNOWLEDGEMENTS

P. K. Maji and S. K. Bera gratefully acknowledge UGC, India for financial support under Minor Research Programme. R. U. Islam gratefully acknowledges Department of Applied Chemistry, Birla Institute of

Technology Mesra, Ranchi, India for financial support. The authors are also grateful to all the co-workers whose work is described in this review for their contribution to the development of metal-catalyzed multicomponent heterocycles syntheses.

## 8. REFERENCES (AND NOTES)

1. The Chemistry of Heterocycles: Structure, Reactions, Synthesis, and Applications, ed. by T. Eicher and S. Hauptmann, Wiley-VCH: Weinheim, 2003.
2. R. Kumar, K. S. Nagabhushana, and N. W. Mal, *Chem. Indus. Digest Ann.*, 2009, **21**, 135.
3. For a recent monograph, see *Multicomponent Reactions*, ed. by J. Zhu and H. Bienaymé, Wiley-VCH, Weinheim, 2005.
4. For reviews, see a) A. Dömling, *Chem. Rev.*, 2006, **106**, 17; b) R. V. A. Orru and M. de Greef, *Synthesis*, 2003, 1471; c) H. Bienaymé, C. Hulme, G. Odon, and P. Schmitt, *Chem. Eur. J.*, 2000, **6**, 3321; d) A. Dömling and I. Ugi, *Angew. Chem. Int. Ed.*, 2000, **39**, 3168; e) I. Ugi, A. Dömling, and B. Werner, *J. Heterocycl. Chem.*, 2000, **37**, 647; f) L. Weber, K. Illgen and M. Almstetter, *Synlett*, 1999, 366; g) R. W. Armstrong, A. P. Combs, P. A. Tempest, S. D. Brown, and T. A. Keating, *Acc. Chem. Res.*, 1996, **29**, 123; h) I. Ugi, A. Dömling, and W. Hörl, *Endeavour*, 1994, **18**, 115; i) G. H. Posner, *Chem. Rev.*, 1986, **86**, 831.
5. For reviews on diversity oriented syntheses, see a) T. J. J. Müller and D. M. D'Souza, *Pure Appl. Chem.*, 2008, **80**, 609; b) T. J. J. Müller, Functional Organic Materials. Syntheses, Strategies, and Applications, ed. by T. J. J. Müller and U. H. F. Bunz, Wiley-VCH Verlag GmbH & Co. KGaA, Weinheim, 2007, p179; c) S. L. Schreiber and M. D. Burke, *Angew. Chem. Int. Ed.*, 2004, **43**, 46; d) M. D. Burke, E. M. Berger, and S. L. Schreiber, *Science*, 2003, **302**, 613; e) P. Arya, D. T. H. Chou, and M. G. Baek, *Angew. Chem. Int. Ed.*, 2001, **40**, 339; f) B. Cox, J. C. Denyer, A. Binnie, M. C. Donnelly, B. Evans, D. V. S. Green, J. A. Lewis, T. H. Mander, A. T. Merritt, M. J. Valler, and S. P. Watson, *Progr. Med. Chem.*, 2000, **37**, 83; g) S. L. Schreiber, *Science*, 2000, **287**, 1964.
6. D. Y. Murzin and R. Leino, *Chem. Eng. Res. Design*, 2008, **86**, 1002.
7. a) Pyrroles, Part II, ed. by R. A. Jones, Wiley, New York, 1992; b) B. A. Trofimov, L. N. Sobenina, A. P. Demenev, and A. I. Mikhaleva, *Chem. Rev.*, 2004, **104**, 2481; c) F. Bellina and R. Rossi, *Tetrahedron*, 2006, **62**, 7213; d) C. F. Lee, L. M. Yang, T. Y. Hwu, and T. Y. Luh, *J. Am. Chem. Soc.*, 2000, **122**, 4992; e) C. W. Boyce, M. A. Labrili, C. A. Sehon, and Q. Jin, *J. Am. Chem. Soc.*, 1999, **121**, 54; f) V. M. Domingo, C. Aleman, E. Brillas, and L. Julia, *J. Org. Chem.*, 2001, **66**, 4058.
8. a) A. Hantzsch, *Ber.*, 1890, **23**, 1474; b) F. Palacios, D. Aparico, J. M. Santos, and J. Vicario, *Tetrahedron*, 2001, **57**, 1961; c) A. W. Trautwein, R. D. Sussmuth, and G. Jung, *Bioorg. Med.*

- [Chem. Lett., 1998, 8, 2381.](#)
9. a) L. Knorr, [Ber. Dtsch. Chem. Ges., 1884, 17, 1635](#); b) C. Paal, [Ber. Dtsch. Chem. Ges., 1885, 18, 367](#); c) B. M. Trost and G. A. Doherty, [J. Am. Chem. Soc., 2000, 122, 3801](#).
10. a) J. L. Bullington, R. R. Wolff, and P. F. Jackson, [J. Org. Chem., 2002, 67, 9439](#); b) A. R. Katritzky, S. Zhang, M. Wang, H. C. Kolb, and P. J. Steel, [J. Heterocycl. Chem., 2002, 39, 759](#); c) K.-I. Washizuka, S. Minakata, I. Ryu, and M. Komatsu, [Tetrahedron, 1999, 55, 12969](#).
11. For selected examples, see: a) E. Benedetti, G. Lemiere, L.-L. Chapellet, A. Penoni, G. Palmisano, M. Malacria, J.-P. Goddard, and L. Fensterband, [Org. Lett., 2010, 12, 4396](#); b) S. Maiti, S. Biswas, and U. Jana, [J. Org. Chem., 2010, 75, 1674](#); c) A. Saito, O. Konishi, and Y. Hanzawa, [Org. Lett., 2010, 12, 372](#); d) J. T. Binder and S. F. Kirsch, [Org. Lett., 2006, 8, 2151](#); e) S. Kramer, J. L. H. Madsen, M. Rottlander, and T. Skrydstrup, [Org. Lett., 2010, 12, 2758](#); f) S. Chiba, Y.-F. Wang, G. Lapointe, and K. Narasaka, [Org. Lett., 2008, 10, 313](#).
12. E. Merkul, C. Boersch, W. Frank, and T. J. J. Müller, [Org. Lett., 2009, 11, 2269](#).
13. X. Chen, L. Hou, and X. Li, [Synlett, 2009, 828](#).
14. S. Dey, C. Pal, D. Nandi, V. S. Giri, M. Zaidlewicz, M. Krzeminski, L. Smentek, B. A. Hess, J. Gawronski, M. Kwit, N. J. Babu, A. Nangia, and P. Jaisankar, [Org. Lett., 2008, 10, 1373](#).
15. V. Cadierno, J. Gimeno, and N. Nebra, [Chem. Eur. J., 2007, 13, 9973](#).
16. B. Gabriele, L. Veltri, R. Mancuso, G. Salerno, S. Maggi, and B. M. Aresta, [J. Org. Chem., 2012, 77, 4005](#).
17. T. Murata, M. Murai, Y. Ikeda, K. K. Miki, and K. Ohe, [Org. Lett., 2012, 14, 2296](#).
18. E. Ghabraie, S. Balalaie, M. Bararjanian, H. R. Bijanzadeh, and F. Rominger, [Tetrahedron, 2011, 67, 5415](#).
19. D. Hong, Y. Zhu, Y. Li, X. Lin, P. Lu, and Y. Wang, [Org. Lett., 2011, 13, 4668](#).
20. S. Zhang, J. Zhao, W.-X. Zhang, and Z. Xi, [Org. Lett., 2011, 13, 1626](#).
21. C. V. Galliford and K. A. Scheidt, [J. Org. Chem., 2007, 72, 1811](#).
22. G. Dou, C. Shi, and D. Shi, [J. Comb. Chem., 2008, 10, 810](#).
23. G. Shanthi and P. T. Perumal, [Tetrahedron Lett., 2009, 50, 3959](#).
24. A. T. Khan, M. Lal, P. R. Bagdi, R. S. Basha, P. Saravanan, and S. Patra, [Tetrahedron Lett., 2012, 53, 4145](#).
25. a) J. E. Saxton, [Nat. Prod. Rep., 1997, 14, 559](#); b) M. Toyota and N. Ihara, [Nat. Prod. Rep., 1998, 15, 327](#); c) J. A. Joule, Product Class 13: Indole and Its Derivatives; Thieme: Stuttgart, 2001; d) T. Kawasaki and K. Higuchi, [Nat. Prod. Rep., 2005, 22, 761](#); e) G. R. Humphrey and J. T. Kuethe, [Chem. Rev., 2006, 106, 2875](#).
26. For reviews on indole chemistry, see: a) R. J. Sundberg, *Indoles*; Academic: London, 1996; b) A.

- R. Katritzky and A. F. Pozharskii, *Handbook of Heterocyclic Chemistry*; Pergamon: Oxford, 2000; Chapter 4; c) J. J. Li and G. W. Gribble, In *Palladium in Heterocyclic Chemistry*; Pergamon: Oxford, 2000; Chapter 3; d) K. Kruger, A. Tillack, and M. Beller, *Adv. Synth. Catal.*, **2008**, **350**, 2139.
27. a) E. Fischer and F. Jourdan, *Ber. Dtsch. Chem. Ges.*, **1883**, **16**, 2241; b) E. Fischer and O. Hess, *Ber. Dtsch. Chem. Ges.*, **1884**, **17**, 559; c) B. Robinson, *The Fischer Indole Synthesis*, John Wiley and Sons, Chichester, 1982; d) D. L. Hughes, *Org. Prep. Proced. Int.*, **1993**, **25**, 607; e) L. E. Kaim, L. Grimaud, and C. Ronsseray, *Synlett*, **2010**, 2296.
28. a) S. Cacchi and G. Fabrizi, *Chem. Rev.*, **2005**, **105**, 2873; b) C. V. Stevens, E. Van Meenen, Y. Eeckhout, B. Vanderhoydonck, and W. Hooghe, *Chem. Commun.*, **2005**, **38**, 4827; c) N. Batail, A. Bendjeriou, L. Djakovitch, and V. Dufaud, *Appl. Catal., A*, **2010**, **388**, 179; d) S. V. Jeught, N. D. Vos, K. Masschelein, I. Ghiviriga, and C. V. Stevens, *Eur. J. Org. Chem.*, **2010**, 5444.
29. a) R. C. Larock and S. Babu, *Tetrahedron Lett.*, **1987**, **28**, 1037; b) R. C. Larock and E. K. Yum, *J. Am. Chem. Soc.*, **1991**, **113**, 6689; c) R. C. Larock, E. K. Yum, and M. D. Refvik, *J. Org. Chem.*, **1998**, **63**, 7652; d) G. Huang and R. C. Larock, *J. Org. Chem.*, **2003**, **68**, 7342; e) Y. Jia and J. Zhu, *J. Org. Chem.*, **2006**, **71**, 7826; f) J. Zhao and R. C. Larock, *J. Org. Chem.*, **2006**, **71**, 5340; g) G. Zeni and R. C. Larock, *Chem. Rev.*, **2006**, **106**, 4644; h) S. Patil and J. K. Buolamwini, *Curr. Org. Synth.*, **2006**, **3**, 477.
30. J. Barluenga, A. Jiménez-Aquino, C. Valdés, and F. Aznar, *Angew. Chem. Int. Ed.*, **2007**, **46**, 1529.
31. Z. Chen, D. Zheng, and J. Wu, *Org. Lett.*, **2011**, **13**, 848.
32. Y. Liu and J.-W. Sun, *J. Org. Chem.*, **2012**, **77**, 1191.
33. D. Marosvolgyi-Hasko, A. Petz, A. Takacs, and L. Kollar, *Tetrahedron*, **2011**, **67**, 9122.
34. a) N. L. Chavan, S. K. Nayak, and R. S. Kusurkar, *Tetrahedron*, **2010**, **66**, 1827; b) F. Liger, F. Popowycz, T. Besson, L. Picot, C. M. Galmarini, and B. Joseph, *Bioorg. Med. Chem.*, **2007**, **15**, 5615; c) J. R. Dormoy and A. Heymes, *Tetrahedron*, **1993**, **49**, 2885; d) M. Alvarez, D. Fernandez, and J. A. Joule, *Synthesis*, **1999**, 615; e) N. R. Curtius, J. J. Kulagowski, P. D. Leeson, M. P. Redgill, F. Emms, S. B. Freedman, and S. Patel, *Bioorg. Med. Chem. Lett.*, **1999**, **9**, 585.
35. R. Suresh, S. Muthusubramanian, R. Senthilkumaran, and G. Manickam, *J. Org. Chem.*, **2012**, **77**, 1468.
36. Y. Liang, T. Meng, H.-J. Zhang, and Z. Xi, *Synlett*, **2011**, 911.
37. The first report for ketenimine, see: H. Staudinger and E. Hauser, *Helv. Chim. Acta*, **1921**, **4**, 887.
38. For reviews on formation and synthetic applications of ketenimines, see: a) P. Lu and Y. G. Wang, *Synlett*, **2010**, 165; b) E. J. Yoo and S. Chang, *Curr. Org. Chem.*, **2009**, **13**, 1766; c) J. E. Hein and V. V. Fokin, *Chem. Soc. Rev.*, **2010**, **39**, 1302; d) G. R. Krow, *Angew. Chem., Int. Ed. Engl.*, **1971**,

- [10, 435](#).
39. a) V. V. Rostovtsev, L. G. Green, V. V. Fokin, and K. B. Sharpless, *Angew. Chem. Int. Ed.*, **2002**, [41, 2596](#); b) C. W. Tornøe, C. Christensen, and M. Meldal, *J. Org. Chem.*, **2002**, [67, 3057](#); c) E. J. Yoo, M. Ahlquist, I. Bae, K. B. Sharpless, V. V. Fokin and S. Chang, *J. Org. Chem.*, **2008**, [73, 5520](#).
40. a) I. Bae, H. Han, and S. Chang, *J. Am. Chem. Soc.*, **2005**, [127, 2038](#); b) S. H. Cho, E. J. Yoo, I. Bae, and S. Chang, *J. Am. Chem. Soc.*, **2005**, [127, 16046](#); c) S. H. Cho and S. Chang, *Angew. Chem. Int. Ed.*, **2007**, [46, 1897](#); d) E. J. Yoo and S. Chang, *Org. Lett.*, **2008**, [10, 1163](#); e) J. Kim, Y. Lee, J. Lee, Y. Do, and S. Chang, *J. Org. Chem.*, **2008**, [73, 9454](#); f) E. J. Yoo, S. H. Park, S. H. Lee, and S. Chang, *Org. Lett.*, **2009**, [11, 1155](#); g) S. L. Cui, X. F. Lin, and Y. G. Wang, *Org. Lett.*, **2006**, [8, 4517](#); h) S. L. Cui, J. Wang, and Y. G. Wang, *Org. Lett.*, **2007**, [9, 5023](#); i) J. She, Z. Jiang, and Y. G. Wang, *Synlett*, **2009**, [2023](#); j) W. Lu, S. W. Song, D. Hong, P. Lu, and Y. G. Wang, *Adv. Synth. Catal.*, **2009**, [351, 1768](#); k) H. W. Jin, X. L. Xu, J. R. Gao, J. H. Zhong, and Y. G. Wang, *Adv. Synth. Catal.*, **2010**, [352, 347](#); l) M. P. Cassidy, J. Raushel, and V. V. Fokin, *Angew. Chem. Int. Ed.*, **2006**, [45, 3154](#); m) M. Whiting and V. V. Fokin, *Angew. Chem. Int. Ed.*, **2006**, [45, 3157](#); n) X. Xu, D. Cheng, J. Li, H. Guo, and J. Yan, *Org. Lett.*, **2007**, [9, 1585](#).
41. H. Jin, B. Zhou, Z. Wu, Y. Shen, and Y. Wang, *Tetrahedron*, **2011**, [67, 1178](#).
42. Y. Suzuki, Y. Ohta, S. Oishi, N. Fujii, and H. Ohno, *J. Org. Chem.*, **2009**, [74, 4246](#).
43. B. Yan and Y. Liu, *Org. Lett.*, **2007**, [9, 4323](#).
44. S. Mishra, B. Naskar, and R. Ghosh, *Tetrahedron Lett.*, **2012**, [53, 5483](#).
45. a) M. H. Chen, P. Pollard, A. Patchett, K. Cheng, L. Wei, W. S. Chan, B. Buttler, T. M. Jacks, and R. G. Smith, *Bioorg. Med. Chem. Lett.*, **1999**, [9, 261](#); b) R. K. Behara, A. K. Behara, R. Pradhan, A. Pati, and M. Patra, *Synth. Commun.*, **2006**, [36, 3729](#).
46. a) C. Marti and E. M. Carreira, *Eur. J. Org. Chem.*, **2003**, [2209](#); b) A. Millemaggi and R. J. K. Taylor, *Eur. J. Org. Chem.*, **2010**, [4527](#).
47. A. Pinto, L. Neuville, and Z. Zhu, *Tetrahedron Lett.*, **2009**, [50, 3602](#).
48. M. Genelot, A. Bendjeriou, V. Dufaud, and L. Djakovitch, *Appl. Catal. A: Gen.*, **2009**, [369, 125](#).
49. C. S. Cho and W. S. Ren, *Tetrahedron Lett.*, **2009**, [50, 2097](#).
50. D. Marosvolgyi-Hasko, A. Takacs, Z. Riedl, and L. Kollar, *Tetrahedron*, **2011**, [67, 1036](#).
51. D. Marosvolgyi-Hasko, A. Petz, A. Takacs, and L. Kollar, *Tetrahedron*, **2011**, [67, 9122](#).
52. C. L. Floch, C. Bughin, E. L. Gall, E. Léonel, and T. Martens, *Tetrahedron Lett.*, **2009**, [50, 5456](#).
53. C. Qi, H. Jiang, L. Huang, G. Yuan, and Y. Ren, *Org. Lett.*, **2011**, [13, 5520](#).
54. S. Li and S. Ma, *Org. Lett.*, **2011**, [13, 6046](#).
55. R.-V. Nguyen and C.-J. Li, *Synlett*, **2008**, [1897](#).

56. H. Li, J. Liu, B. Yan, and Y. Li, *Tetrahedron Lett.*, 2009, **50**, 2353.
57. N. Sakai, N. Uchida, and T. Konakahara, *Tetrahedron Lett.*, 2008, **49**, 3437.
58. L. Zhao, G. Cheng, and Y. Hu, *Tetrahedron Lett.*, 2008, **49**, 7364.
59. For general reviews, see a) A. N. Kost and I. I. Grandberg, *Adv. Heterocycl. Chem.*, 1966, **6**, 347; b) J. Elguero, *In Comprehensive Heterocyclic Chemistry*, ed. by A. R. Katritzky and C. W. Rees, Pergamon, Oxford, 1984, Vol. 5, p 167; c) J. Elguero, *In Comprehensive Heterocyclic Chemistry II*, ed. by A. R. Katritzky, C. W. Rees, and E. F. V. Scriven, Elsevier, Oxford, 1996, Vol. 3, p 1.
60. D. J. Wustrow, T. Capiris, R. Rubin, J. A. Knobelsdorf, H. Akunne, M. D. Davis, R. MacKenzie, T. A. Pugsley, K. T. Zoski, T. G. Heffner, and L. D. Wise, *Bioorg. Med. Chem. Lett.*, 1998, **8**, 2067.
61. T. D. Penning, J. J. Talley, S. R. Bertenshaw, J. S. Carter, P. W. Collins, S. Docter, M. J. Graneto, L. F. Lee, J. W. Malecha, J. M. Miyashiro, R. S. Rogers, D. J. Rogier, S. S. Yu, G. D. Anderson, E. G. Burton, J. N. Cogburn, S. A. Gregory, C. M. Koboldt, W. E. Perkins, K. Seibert, A. W. Veenhuizen, Y. Y. Zhang, and P. C. Isakson, *J. Med. Chem.*, 1997, **40**, 1347.
62. H.-L. Liu, H.-F. Jiang, M. Zhang, W.-J. Yao, Q.-H. Zhu, and Z. Tang, *Tetrahedron Lett.*, 2008, **49**, 3805.
63. B. Willy and T. J. J. Müller, *Eur. J. Org. Chem.*, 2008, 4157.
64. B. Willy and T. J. J. Müller, *Org. Lett.*, 2011, **13**, 2082.
65. L. Shen, S. Cao, N. Liu, J. Wu, L. Zhu, and X. Quin, *Synlett*, 2008, 1341.
66. S. Majumder, K. R. Gipson, R. J. Staples, and A. L. Odom, *Adv. Synth. Catal.*, 2009, **351**, 2013.
67. K. Kumari, D. S. Raghuvanshi, V. Jouikov, and K. N. Singh, *Tetrahedron Lett.*, 2012, **53**, 1130.
68. M. R. Kumar, A. Park, N. Park, and S. Lee, *Org. Lett.*, 2011, **13**, 3542.
69. X.-M. Yan, Z.-M. Chen, F. Yang, and Z.-Z. Huang, *Synlett*, 2011, 569.
70. Y. Suzuki, S. Naoe, S. Oishi, N. Fujii, and H. Ohno, *Org. Lett.*, 2012, **14**, 326.
71. J. P. Stonehouse, D. S. Chekmarev, N. V. Ivanova, S. Lang, G. Pairaudeau, N. Smith, M. J. Stocks, S. I. Sviridov, and L. M. Utkina, *Synlett*, 2008, 100.
72. S. Safaei, I. Mohammadpoor-Baltork, A. R. Khosropour, M. Moghadam, S. Tangestaninejad, and V. Mirkhani, *Synlett*, 2011, 2214.
73. Y. Li, D. Hong, Y. Zhu, P. Lu, and Y. Wang, *Tetrahedron*, 2011, **67**, 8086.
74. S. Li, Y. Luo, and J. Wu, *Org. Lett.*, 2011, **13**, 4312.
75. a) R. M. Chabin, E. McCauley, J. R. Calaycay, T. M. Kelly, K. L. MacNaul, G. C. Wolfe, N. I. Hutchinson, S. Madhusudanaraju, J. A. Schmidt, J. W. Kozarich, and K. K. Wong, *Biochemistry*, 1996, **35**, 9567; b) N. P. Jensen, S. M. Schmitt, T. B. Windholz, and T. Y. Shen, *J. Med. Chem.*, 1972, **15**, 341; c) L. R. Swett and T. O. Yellin, *J. Med. Chem.*, 1970, **13**, 968; d) M. M. Herrador,

- J. S. Buruaga, and M. D. Suarez, [J. Med. Chem., 1985, 28, 146](#); e) J. Gising, M. T. Nilsson, L. R. Odell, S. Yahiaoui, M. Lindh, H. Iyer, A. M. Sinha, B. R. Srinivasa, M. Larhed, S. L. Mowbray, and A. Karlen, [J. Med. Chem., 2012, 55, 2894](#); f) J. G. Lombardino and E. H. Wiseman, [J. Med. Chem., 1974, 17, 1182](#); g) S. D. Zaric, D. M. Popovic, and E. W. Knapp, [Biochemistry, 2001, 40, 7914](#).
76. a) A. Bhatnagar, P. K. Sharma, and N. Kumar, *Int. J. PharmTech. Res.*, 2011, **3**, 268; b) L. De Luca, *Curr. Med. Chem.*, 2006, **13**, 1; c) M. Boiani and M. Gonzalez, [Mini-Rev. Med. Chem., 2005, 5, 409](#).
77. L. Bromberg, L. Chen, E. P. Chang, S. Wang, and T. A. Hatton, [Chem. Mater., 2010, 22, 5383](#).
78. a) H. Debus, *Ann.*, 1858, **107**, 204; b) B. Radziszewski, [Ber. Dtsch. Chem. Ges., 1882, 15, 2706](#).
79. C. F. Huebner, [J. Am. Chem. Soc., 1951, 73, 4667](#).
80. a) V. Gracias, A. F. Gasiiecki, and S. W. Djuric, [Tetrahedron Lett., 2005, 46, 9049](#); b) V. Gracias, D. Darczak, A. F. Gasiiecki, and S. W. Djuric, [Tetrahedron Lett., 2005, 46, 9053](#); c) V. Gracias, A. F. Gasiiecki, T. G. Pagano, and S. W. Djuric, [Tetrahedron Lett., 2006, 47, 8873](#); d) X. Beebe, V. Gracias, and S. W. Djuric, [Tetrahedron Lett., 2006, 47, 3225](#); e) L. Wang, K. W. Woods, Q. Li, K. J. Barr, R. W. McCroskey, S. M. Hannick, L. Gherke, R. B. Credo, Y. H. Hui, K. Marsh, R. Warner, J. Y. Lee, N. Zielinski-Mozng, D. Frost, S. H. Rosenberg, and H. L. Sham, [J. Med. Chem., 2002, 45, 1697](#).
81. a) F. De Moliner and C. Hulme, [Org. Lett., 2012, 14, 1354](#); b) S. Li, Z. K. Li, Y. F. Yuan, D. J. Peng, Y. J. Li, L. S. Zhang, and Y. M. Wu, [Org. Lett., 2012, 14, 1130](#); c) Y. J. Xiao and L. M. Zhang, [Org. Lett., 2012, 14, 4662](#); d) B. Hu, Z. Wang, N. Ai, J. Zheng, X. H. Liu, S. Shan, and Z. W. Wang, [Org. Lett., 2011, 13, 6362](#); e) S. Petit, C. Fruit, and L. Bischoff, [Org. Lett., 2010, 12, 4928](#); f) B. Jiang, X. Wang, F. Shi, S. J. Tu, T. Ai, A. Ballew, and G. Li, [J. Org. Chem., 2009, 74, 9486](#).
82. S. Das Sharma, P. Hazarika, and D. Konwar, [Tetrahedron Lett., 2008, 49, 2216](#).
83. J. Han, T. Li, Y. Pan, A. Kattuboina, and G. Li, [Chem. Biol. Drug Des., 2008, 71, 71](#).
84. K. Worrall, B. Xu, S. Bontemps, and B. A. Arndtsen, [J. Org. Chem., 2011, 76, 170](#).
85. a) S. Bontemps, J. S. Quesnel, K. Worrall, and B. A. Arndtsen, [Angew. Chem. Int. Ed., 2011, 50, 8949](#); b) R. Dhawan, R. D. Dghaym, D. J. St. Cyr, and B. A. Arndtsen, [Org. Lett., 2006, 8, 3927](#).
86. B. Xu, K. Worrall, and B. A. Arndtsen, [Molecules, 2012, 17, 13759](#).
87. Z. Jiang, P. Lu, and Y. Wang, [Org. Lett., 2012, 14, 6266](#).
88. E. F. DiMauro and J. M. Kennedy, [J. Org. Chem., 2007, 72, 1013](#).
89. S. Rostamnia, K. Lamei, M. Mohammadquli, M. Sheykhan, and A. Heydari, [Tetrahedron Lett., 2012, 53, 5257](#).

90. B. V. Subha Reddy, P. Shivaramkrishna Reddy, Y. Jayasudhan Reddy, and J. S. Yadav, [\*Tetrahedron Lett.\*, 2011, \*\*52\*\*, 5789](#).
91. P. Liu, L.-S. Fang, X. Lei, and G.-Q. Lin, [\*Tetrahedron Lett.\*, 2010, \*\*51\*\*, 4605](#).
92. S. Mishra and R. Ghosh, [\*Synthesis\*, 2011, 3463](#).
93. T. Guntreddi, B. K. Allam, and K. N. Singh, [\*Synlett\*, 2012, 2635](#).
94. S. K. Guchhait, A. L. Chandgude, and G. Priyadarshani, [\*J. Org. Chem.\*, 2012, \*\*77\*\*, 4438](#).
95. Y. Kim, M. R. Kumar, N. Park, Y. Heo, and S. Lee, [\*J. Org. Chem.\*, 2011, \*\*76\*\*, 9577](#).
96. B. Willy, F. Rominger, and T. J. J. Müller, [\*Synthesis\*, 2008, 293](#).
97. P. J. Boissarie, Z. E. Hamilton, S. Lang, J. A. Murphy, and C. J. Suckling, [\*Org Lett.\*, 2011, \*\*13\*\*, 6256](#).
98. B. Gabriele, P. Plastina, G. Salerno, R. Mancuso, and M. Costa, [\*Org. Lett.\*, 2007, \*\*9\*\*, 3319](#).
99. W.-J. Yoo and C.-J. Li, *Adv. Synth. Catal.*, 2008, **350**, 1503.
100. G. Satish, K. H. V. Reddy, K. Ramesh, K. Karnakar, and Y. V. D. Nageswar, [\*Tetrahedron Lett.\*, 2012, \*\*53\*\*, 2518](#).
101. L. Shi, X. Liu, H. Zhang, Y. Jiang, and D. Ma, [\*J. Org. Chem.\*, 2011, \*\*76\*\*, 4200](#).
102. K. C. Majumdar, N. De, D. Ghosh, S. Ponra, and B. Roy, [\*Synthesis\*, 2012, 87](#).
103. S. Muthusamy, R. Ramkumar, and A. K. Mishra, [\*Tetrahedron Lett.\*, 2011, \*\*52\*\*, 148](#).
104. R. D. Baxter and J. Montgomery, [\*J. Am. Chem. Soc.\*, 2008, \*\*130\*\*, 9662](#).
105. a) R. Huisgen, G. Szeimies, and L. Moebius, [\*Chem. Ber.\*, 1965, \*\*98\*\*, 4014](#); b) R. Huisgen, [\*Pure Appl. Chem.\*, 1989, \*\*61\*\*, 613](#).
106. C. W. Tornøe, C. Christensen, and M. Meldal, [\*J. Org. Chem.\*, 2002, \*\*67\*\*, 3057](#).
107. V. V. Rostovtsev, L. G. Green, V. V. Fokin, and K. B. Sharpless, [\*Angew. Chem. Int. Ed.\*, 2002, \*\*41\*\*, 2596](#).
108. a) V. D. Bock, H. Hiemstra, and J. H. van Maarseveen, [\*Eur. J. Org. Chem.\*, 2006, 51](#); b) M. Meldal and C. W. Tornøe, [\*Chem. Rev.\*, 2008, \*\*108\*\*, 2952](#); c) P. Appukkuttan and E. Van der Eycken, [\*Eur. J. Org. Chem.\*, 2008, 1133](#); d) C. O. Kappe and E. Van der Eycken, [\*Chem. Soc. Rev.\*, 2010, \*\*39\*\*, 1280](#).
109. a) J. A. Anderson and M. F. García, ed., *Catalytic Science Series*; Imperial College Press: London, 2005; b) K. Kaneda, K. Ebitani, T. Mizugaki, and K. Mori, [\*Bull. Chem. Soc. Jpn.\*, 2006, \*\*79\*\*, 981](#).
110. For recent reviews, see a) J. Sun and X. Bao, [\*Chem. Eur. J.\*, 2008, \*\*14\*\*, 7478](#); b) R. J. White, R. Luque, V. L. Budarin, J. H. Clark, and D. J. Macquarrie, [\*Chem. Soc. Rev.\*, 2009, \*\*38\*\*, 481](#); c) J. M. Campelo, D. Luna, F. Luque, J. M. Marinas, and A. A. Romero, [\*ChemSusChem.\*, 2009, \*\*2\*\*, 18](#); d) L. De Rogatis, M. Cargnello, V. Gombac, B. Lorenzut, T. Montini, and P. Fornasiero, [\*ChemSusChem.\*, 2010, \*\*3\*\*, 24](#); e) L. D. Pachon, J. H. van Maarseveen, and G. Rothenberg, [\*Adv.\*](#)

- [Synth. Catal.](#), 2005, **347**, 811.
111. For recent reviews, see a) A. Chanda and V. V. Fokin, [Chem. Rev.](#), 2009, **109**, 725; b) R. N. Butler and A. G. Coyne, [Chem. Rev.](#), 2010, **110**, 6302.
112. For recent reviews, see a) K. Kumaravel and G. Vasuki, [Curr. Org. Chem.](#), 2009, **13**, 1820; b) E. J. Yoo and S. Chang, [Curr. Org. Chem.](#), 2009, **13**, 1766; c) B. Jiang, T. Rajale, W. Wever, S.-J. Tu, and G. Li, [Chem. Asian J.](#), 2010, **5**, 2318; d) D. J. Ramon and M. Yus, [Angew. Chem. Int. Ed.](#), 2005, **44**, 1602.
113. a) M. Lakshmi Kantam, V. S. Jaya, B. Sreedhar, M. Mohan Rao, and B. M. Choudary, [J. Mol. Catal. A](#), 2006, **256**, 273; b) H. Sharghi, R. Khalifeh, and M. M. Doroodmand, [Adv. Synth. Catal.](#), 2009, **351**, 207; c) V. Beneteau, A. Olmos, T. Boningari, J. Sommer, and P. Pale, [Tetrahedron Lett.](#), 2010, **51**, 3673.
114. L. Ackermann, H. K. Potukuchi, D. Landsberg, and R. Vicente, [Org. Lett.](#), 2008, **10**, 3081.
115. J. Kalisiak, K. B. Sharpless, and V. V. Fokin, [Org. Lett.](#), 2008, **10**, 3171.
116. S.-I. Fukuzawa, E. Shimizu and S. Kikuchi, [Synlett](#), 2007, 2436.
117. H. S. G. Beckmann and V. Wittmann, [Org. Lett.](#), 2007, **9**, 1.
118. K. Barral, A. D. Moorhouse, and J. E. Moses, [Org. Lett.](#), 2007, **9**, 1809.
119. A. D. Moorhouse and J. E. Moses, [Synlett](#), 2008, 2089.
120. J. S. Yadav, B. V. Subba Reddy, G. Madhusudhan Reddy, and D. N. Chary, [Tetrahedron Lett.](#), 2007, **49**, 8773.
121. a) F. Alonso, Y. Moglie, G. Radivoy, and M. Yus, [Tetrahedron Lett.](#), 2009, **50**, 2358; b) A. Sarkar, T. Mukherjee, and S. Kapoor, [J. Phys. Chem. C](#), 2008, **112**, 3334; c) H. Elayadi, M. A. Ali, A. Mehdi, and H. B. Lazrek, [Catal. Commun.](#), 2012, **26**, 155; d) R. B. N. Baig and R. S. Varma, [Green Chem.](#), 2012, **14**, 625; e) R. Hudson, C.-J. Li, and A. Moores, [Green Chem.](#), 2012, **14**, 622.
122. F. Alonso, Y. Moglie, G. Radivoy and M. Yus, [J. Org. Chem.](#), 2011, **76**, 8394.
123. a) S. Grasso, G. Desarro, N. Micale, M. Zappala, G. Puia, M. Baraldi, and C. Demicheli, [J. Med. Chem.](#), 2000, **43**, 2851; b) N. Watanabe, Y. Kabasawa, Y. Takase, M. Matsukura, K. Miyazaki, H. Ishihara, K. Kodama, and H. Adachi, [J. Med. Chem.](#), 1998, **41**, 3367; c) P. Salehi, D. I. MaGee, M. Dabiri, L. Torkian, and J. Donahue, [Mol. Divers.](#), 2012, **16**, 231.
124. B. Sreedhar, P. S. Seddy, and V. Rama Krishna, [Tetrahedron Lett.](#), 2007, **48**, 5831.
125. W. Qian, D. Winternheimer, and J. Allen, [Org. Lett.](#), 2011, **13**, 1682.
126. J. S. Yadav, B. V. Subba Reddy, G. Madhusudhan Reddy, and S. Rehana Anjum, [Tetrahedron Lett.](#), 2009, **50**, 6029.
127. J. S. Yadav, B. V. S. Reddy, D. N. Chary, and C. S. Reddy, [Tetrahedron Lett.](#), 2008, **49**, 2649.
128. H. Ankati, [Tetrahedron Lett.](#), 2009, **50**, 4677.

129. B. S. P. A. Kumar, K. H. V. Reddy, B. Madhav, K. Ramesh, and Y. V. D. Nageswar, [Tetrahedron Lett., 2012, 53, 4595](#).
130. F. Alonso, Y. Moglie, G. Radivoy, and M. Yus, [Synlett, 2012, 2179](#).
131. S. Ladouceur, A. M. Soliman, and E. Zysman-Colman, [Synthesis, 2011, 3604](#).
132. S. Sarkar, S. Dutta, and A. K. Sen, [Synthesis, 2012, 1079](#).
133. N. Li, D. Wang, J. Li, W. Shi, C. Li and B. Chen, [Tetrahedron Lett., 2011, 52, 980](#).
134. L. Li, G. Zhang, A. Zhu, and L. Zhang, [J. Org. Chem., 2008, 73, 3630](#).
135. J. T. Fletcher and J. E. Reilly, [Tetrahedron Lett., 2011, 52, 5512](#).
136. a) F. X. Felpin and E. Fouquet, [ChemSusChem, 2008, 1, 718](#); b) M. G. Finn and V. V. Fokin, [Chem. Soc. Rev., 2010, 39, 1231](#); c) P. Wu and V. V. Fokin, *Aldrichimica Acta*, 2007, **40**, 7.
137. S. Lal and S. Díez-Gonzalez, [J. Org. Chem., 2011, 76, 2367](#).
138. A. Kolarovic, M. Schnurch, and M. D. Mihovilovic, [J. Org. Chem., 2011, 76, 2613](#).
139. S. Mohammed, A. K. Padala, B. A. Dar, B. Singh, B. Sreedhar, R. A. Vishwakarma, and S. B. Bharate, [Tetrahedron, 2012, 68, 8156](#).
140. L. K. Rasmussen, B. C. Boren and V. V. Fokin, [Org. Lett., 2007, 9, 5337](#).
141. J. R. Johansson, P. Lincoln, B. Norden, and N. Kann, [J. Org. Chem., 2011, 76, 2355](#).
142. Y. Zhang, X. Li, J. Li, J. Chen, X. Meng, M. Zhao, and B. Chen, [Org. Lett., 2012, 14, 26](#).
143. D. Kundu, A. Majee, and A. Hajra, [Tetrahedron Lett., 2009, 50, 2668](#).
144. T. Yue, M.-X. Wang, D.-X. Wang, and J. Zhu, [Angew. Chem. Int. Ed., 2008, 47, 9454](#).
145. H. Yanai, T. Sakiyama, T. Oguchi and T. Taguchi, [Tetrahedron Lett., 2012, 53, 3161](#).
146. O. De Paolis, J. Baffoe, S. M. Landge, and B. Torok, [Synthesis, 2008, 3423](#).
147. P. V. Shinde, V. B. Labade, J. B. Gujar, B. B. Shingate, and M. S. Shingare, [Tetrahedron Lett., 2012, 53, 1523](#).
148. P. A. Clarke, A. V. Zaytzev, and A. C. Whitewood, [Tetrahedron Lett., 2007, 48, 5209](#).
149. G. Brahmachari and S. Das, [Tetrahedron Lett., 2012, 53, 1479](#).
150. S. Mishra and R. Ghosh, [Tetrahedron Lett., 2011, 52, 2857](#).
151. J. Barluenga, A. Jiménez-Aquino, M. A. Fernández, F. Aznar, and C. Valdés, [Tetrahedron, 2008, 64, 778](#).
152. N. M. Evdokimov, A. S. Kireev, A. A. Yakovenko, M. Y. Antipin, I. V. Magedov, and A. Kornienko, [J. Org. Chem., 2007, 72, 3443](#).
153. M. Sridhar, B. C. Ramanaiyah, C. Narsaiyah, B. Mahesh, M. Kumaraswamy, K. K. R. Mallu, V. M. Ankathi, and P. S. Rao, [Tetrahedron Lett., 2009, 50, 3897](#).
154. M. Thimmaiah, P. Li, S. Regati, B. Chen, and J. C.-G. Zhao, [Tetrahedron Lett., 2012, 53, 4870](#).
155. M. R. P. Heravi and F. Fakhr, [Tetrahedron Lett., 2011, 52, 6779](#).

156. J. Tang, L. Wang, Y. Yao, L. Zhang, and W. Wang, *Tetrahedron Lett.*, 2011, **52**, 509.
157. N. Mahajan, A. Sambyal, A. P. S. Pannu, and T. K. Razdan, *Tetrahedron Lett.*, 2011, **52**, 1265.
158. a) L. Zhao, F. Liang, X. Bi, S. Sun, and Q. Liu, *J. Org. Chem.*, 2006, **71**, 1094; b) L. Dong, S. Aleem, and C. A. Fink, *Tetrahedron Lett.*, 2010, **51**, 5210.
159. D. Yang, S. Burugupalli, D. Daniel, and Y. Chen, *J. Org. Chem.*, 2012, **77**, 4466.
160. V. Sridharan, P. T. Perumal, C. Avendaño, and J. C. Menéndez, *Tetrahedron*, 2007, **63**, 4407.
161. S. Sueki, R. Takei, J. Abe, and I. Shimizu, *Tetrahedron Lett.*, 2011, **52**, 4473.
162. E. Yamuna, M. Zeller, and K. J. R. Prasad, *Tetrahedron Lett.*, 2011, **52**, 6805.
163. P. Mizar and B. Myrboh, *Tetrahedron Lett.*, 2009, **50**, 3088.
164. A. A. Kudale, J. Kendall, D. O. Miller, J. L. Collins, and G. J. Bodwell, *J. Org. Chem.*, 2008, **73**, 8437.
165. P. A. Clarke, A. V. Zaytsev, T. W. Morgan, A. C. Whitwood, and C. Wilson, *Org. Lett.*, 2008, **10**, 2877.
166. P. J. Alaimo, R. O'Brien, III, A. W. Johnson, S. R. Slauson, J. M. O'Brien, E. L. Tyson, A.-L. Marshall, C. E. Ottinger, J. C. Chacon, L. Wallace, C. Y. Paulino, and S. Connell, *Org. Lett.*, 2008, **10**, 5111.
167. N. Isambert, M. Cruz, M. J. Arévalo, E. Gómez, and R. Lavilla, *Org. Lett.*, 2007, **9**, 4199.
168. V. Gaddam and R. Nagarajan, *Tetrahedron Lett.*, 2009, **50**, 1243.
169. A. T. Khan, D. K. Das, and M. M. Khan, *Tetrahedron Lett.*, 2011, **51**, 4539.
170. B. H. S. T. da Silva, L. M. Martins, and L. C. da Silva-Filho, *Synlett*, 2012, 1973.
171. E. Vicente-García, F. Catti, R. Ramón, and R. Lavilla, *Org. Lett.*, 2010, **12**, 860.
172. E. Vicente-García, R. Ramón, and R. Lavilla, *Synthesis*, 2011, 2237.
173. X. S. Wang, J. Zhou, K. Yang, and C. S. Yao, *Tetrahedron Lett.*, 2010, **51**, 5721.
174. S. B. Sakal, K. F. Shelke, B. B. Shingate, and M. S. Shingare, *Tetrahedron Lett.*, 2009, **50**, 1754.
175. M. Saha and A. K. Pal, *Tetrahedron Lett.*, 2011, **52**, 4872.
176. J. M. Khurana, A. Chaudhary, B. Nand, and A. Lumb, *Tetrahedron Lett.*, 2012, **53**, 3018.
177. P. S. Naidu, P. Borah, and P. J. Bhuyan, *Tetrahedron Lett.*, 2012, **53**, 4015.
178. M. Dell'Acqua, G. Abbiati, and E. Rossi, *Synlett*, 2010, 2672.
179. S. Ramesh and R. Nagarajan, *Synlett*, 2012, 717.
180. A. Kumar and V. K. Rao, *Synlett*, 2011, 2157.
181. For selected examples, see a) K. W. Bentley, *The Isoquinoline Alkaloids*, Harwood Academic, Australia, 1998, Vol. 1; b) J. D. Phillipson, M. F. Roberts, and M. H. Zenk, *The Chemistry and Biology of Isoquinoline Alkaloids*, Springer, New York, NY, 1985.
182. For selected examples, see a) B. W. Trotter, K. K. Nanda, N. R. Kett, C. P. Regan, J. J. Lynch, G.

- L. Stump, L. Kiss, J. Wang, R. H. Spencer, S. A. Kane, R. B. White, R. Zhang, K. D. Anderson, N. J. Liverton, C. J. McIntyre, D. C. Beshore, G. D. Hartman, and C. J. Dinsmore, *J. Med. Chem.*, **2006**, **49**, 6954; b) P. Ramesh, N. S. Reddy, and Y. Venkateswarlu, *J. Nat. Prod.*, **1999**, **62**, 780; c) T. Kaneda, Y. Takeuchi, H. Matsui, K. Shimizu, N. Urakawa, and S. Nakajyo, *J. Pharm. Sci.*, **2005**, **98**, 275; d) C. Marchand, S. Antony, K. W. Kohn, M. Cushman, A. Ioanoviciu, B. L. Staker, A. B. Burgin, L. Stewart, and Y. Pommier, *Mol. Cancer Ther.*, **2006**, **5**, 287.
183. Z. Guo, M. Cai, J. Jiang, L. Yang, and W. Hu, *Org. Lett.*, **2010**, **12**, 652.
184. S. Li and J. Wu, *Org. Lett.*, **2011**, **13**, 712.
185. T. Fukutani, N. Umeda, K. Hirano, T. Satoh, and M. Miura, *Chem. Commun.*, **2009**, 5141.
186. J. Jayakumar, K. Parthasarathy, and C.-H. Cheng, *Angew. Chem. Int. Ed.*, **2012**, **51**, 197.
187. J. Parthasarathy, N. Senthilkumar, J. Jayakumar, and C.-H. Cheng, *Org. Lett.*, **2012**, **14**, 3478.
188. H.-C. Ouyang, R.-Y. Tang, P. Zhong, X.-G. Zhang, and J.-H. Li, *J. Org. Chem.*, **2011**, **76**, 223.
189. a) Z. Chen, X. Yu, and J. Wu, *Chem. Commun.*, **2010**, **46**, 6356; b) X. Yu and J. Wu, *J. Comb. Chem.*, **2010**, **12**, 238; c) S. Ye and J. Wu, *Tetrahedron Lett.*, **2009**, **50**, 6273; d) H. Zhou, H. Jin, S. Ye, X. He, and J. Wu, *Tetrahedron Lett.*, **2009**, **50**, 4616; e) X. Yu, Q. Ding, Z. Chen, and J. Wu, *Tetrahedron Lett.*, **2009**, **50**, 4279; f) Q. Ding, Z. Wang, and J. Wu, *Tetrahedron Lett.*, **2009**, **50**, 198; g) S. Ye, H. Zhou, and J. Wu, *Tetrahedron*, **2009**, **65**, 1294; h) Y. Ye, Q. Ding, and J. Wu, *Tetrahedron*, **2008**, **64**, 1378; i) Q. Ding and J. Wu, *Org. Lett.*, **2007**, **9**, 4959; j) K. Gao and J. Wu, *J. Org. Chem.*, **2007**, **72**, 8611; k) Q. Ding, Y. Ye, R. Fan, and J. Wu, *J. Org. Chem.*, **2007**, **72**, 5439; l) W. Sun, Q. Ding, X. Sun, R. Fan, and J. Wu, *J. Comb. Chem.*, **2007**, **9**, 690; m) Q. Ding, B. Wang, and J. Wu, *Tetrahedron*, **2007**, **63**, 12166.
190. H. Lou, S. Ye, J. Zhang, and J. Wu, *Tetrahedron*, **2011**, **67**, 2060.
191. M. Bakherad, A. Keivanloo, and S. Jajarmi, *Tetrahedron*, **2012**, **68**, 2107.
192. L. Zheng, J. Ju, Y. Bin, and R. Hua, *J. Org. Chem.*, **2012**, **77**, 5794.
193. B. Das, P. Jangili, J. Kashanna, and R. A. Kumar, *Synthesis*, **2011**, 3267.
194. Y. Ohta, S. Oishi, N. Fujii, and H. Ohno, *Chem. Commun.*, **2008**, 835.
195. F. Sha and X. Huang, *Angew. Chem.*, **2009**, **121**, 3510; *Angew. Chem. Int. Ed.*, **2009**, **48**, 3458.
196. S. Ye and J. Wu, *Tetrahedron Lett.*, **2009**, **50**, 6273.
197. M. Yu, Y. Wang, C.-J. Li, and X. Yao, *Tetrahedron Lett.*, **2009**, **50**, 6791.
198. H. Zhou, H. Jin, S. Ye, X. He, and J. Wu, *Tetrahedron Lett.*, **2009**, **50**, 4616.
199. S. H. S. Azzam, A. Siddekh, and M. A. Pasha, *Tetrahedron Lett.*, **2012**, **53**, 6306.
200. M. Genelot, V. Dufaud, and L. Djakovitch, *Tetrahedron*, **2011**, **67**, 976.
201. Z. Zheng and H. Alper, *Org. Lett.*, **2008**, **10**, 4903.
202. V. Tyagi, S. Khan, V. Bajpai, H. M. Gauniyal, B. Kumar, and P. M. S. Chauhan, *J. Org. Chem.*,

- [2012, 77, 1414.](#)
203. K. Okuro and H. Alper, *J. Org. Chem.*, 2012, **77**, 4420.
204. K. Okuro and H. Alper, *Tetrahedron Lett.*, 2012, **53**, 4816.
205. M. P. Surpur, S. Kshirsagar, and S. D. Samant, *Tetrahedron Lett.*, 2009, **50**, 719.
206. J. S. Yadav, B. V. Subha Reddy, S. K. Biswas, and S. Sengupta, *Tetrahedron Lett.*, 2009, **50**, 5798.
207. B. V. Subba Reddy, M. Ramana Reddy, G. Narasimhulu, and J. S. Jadav, *Tetrahedron Lett.*, 2010, **51**, 5677.
208. N. Seshu Babu, N. Pasha, K. T. V. Rao, P. S. S. Prasad, and N. Lingaiah, *Tetrahedron Lett.*, 2008, **49**, 2730.
209. P. Bhattacharyya, K. Pradhan, S. Paul, and A. R. Das, *Tetrahedron Lett.*, 2012, **53**, 4687.
210. B. Karmakar, A. Nayak, and J. Banerji, *Tetrahedron Lett.*, 2012, **53**, 5004.
211. X.-N. Zhang, Y.-X. Li, and Z.-H. Zhang, *Tetrahedron*, 2011, **67**, 7426.
212. S. Samai, G. C. Nandi, and M. S. Singh, *Tetrahedron*, 2012, **68**, 1247.
213. G. Shanthi and P. T. Perumal, *Tetrahedron Lett.*, 2007, **48**, 6785.
214. S. Paul, P. Bhattacharyya, and A. R. Das, *Tetrahedron Lett.*, 2011, **52**, 4636.
215. G. C. Nandi, S. Samai, R. Kumar, and M. S. Singh, *Tetrahedron*, 2009, **65**, 7129.
216. Q. Zhang, H. Su, J. Luo, and Y. Wei, *Green Chem.*, 2012, **14**, 201.
217. R. Kumar, K. Raghuvanshi, R. K. Verma, and M. S. Singh, *Tetrahedron Lett.*, 2010, **51**, 5933.
218. J. S. Yadav, B. V. Subha Reddy, T. Maity, and G. G. K. S. N. Kumar, *Tetrahedron Lett.*, 2007, **48**, 8874.
219. U. K. Roy, P. K. Jana, and S. Roy, *Tetrahedron Lett.*, 2007, **48**, 1183.
220. Y. Li, Z. Yu, and H. Alper, *Org. Lett.*, 2007, **9**, 1647.
221. W. Chen, Y. Cai, X. Fu, X. Liu, L. Lin, and X. Feng, *Org. Lett.*, 2011, **13**, 4910.
222. W. H. dos Santos and L. C. da Silva-Filho, *Synthesis*, 2012, 3361.
223. K. Palanichamy, S. R. Suravarapu, and K. P. Kaliappan, *Synthesis*, 2012, 1841.
224. B. Willy and T. J. J. Muller, *Synlett*, 2009, 1255.
225. W. Lu, W. Song, D. Hong, P. Lu, and Y. Wang, *Adv. Synth. Catal.*, 2009, **351**, 1768.
226. T. Sasada, F. Kobayashi, N. Sakai, and T. Konakahara, *Org. Lett.*, 2009, **11**, 2161.
227. H. Cao, X. Wang, H. Jiang, Q. Zhu, M. Zhang, and H. Liu, *Chem. Eur. J.*, 2008, **14**, 11623.
228. A. Dandia, A. K. Jain, and S. Sharma, *Tetrahedron Lett.*, 2012, **53**, 5270.
229. a) T. Vlaar, E. Ruijter, and R. V. A. Orru, *Adv. Synth. Catal.*, 2011, **353**, 809; b) G. Van Baelen, S. Kuijter, L. Rycek, S. Sergeev, E. Janssen, F. J. J. de Kanter, B. U. W. Maes, E. Ruijter, and R. V. A. Orru, *Chem. Eur. J.*, 2011, **17**, 15039.
230. T. Vlaar, E. Ruijter, A. Znabet, E. Janssen, F. J. J. de Kanter, B. U. W. Maes, and R. V. A. Orru,

- [Org. Lett., 2011, 13, 6496.](#)
231. C. Mukhopadhyay, S. Rana, and R. J. Butcher, [Tetrahedron Lett., 2011, 52, 4153.](#)
232. S. Gupta, S. K. Sharma, A. K. Mandadapu, H. M. Gauniyal, and B. Kundu, [Tetrahedron Lett., 2011, 52, 4288.](#)
233. K. K. Pasunooti, H. Chai, C. N. Jensen, B. K. Goritala, S. Wang, and X. W. Liu, [Tetrahedron Lett., 2011, 52, 80.](#)
234. B. K. Banik, A. T. Reddy, A. Datta, and C. Mukhopadhyay, [Tetrahedron Lett., 2007, 48, 7392.](#)
235. T. N. Glasnov, H. Tye, and C. O. Kappe, [Tetrahedron, 2008, 64, 2035.](#)
236. P. Li, S. Regati, R. J. Butcher, H. D. Arman, Z. Chen, S. Xiang, B. Chen, and C.-G. Zhao, [Tetrahedron Lett., 2011, 52, 6220.](#)
237. O. M. Singh and N. S. Devi, [J. Org. Chem., 2009, 74, 3141.](#)
238. M. Zhang and H.-F. Jiang, [Eur. J. Org. Chem., 2008, 3519.](#)
239. P. Mizar and B. Myrboh, [Tetrahedron Lett., 2008, 49, 5283.](#)
240. R. N. Bhattacharya, P. Kundu, and G. Maiti, [Tetrahedron Lett., 2011, 52, 26.](#)
241. a) C. S. Jang, F. Y. Fu, C. Y. Wang, K. C. Haung, G. Lu, and T. C. Thou, [Science, 1946, 103, 59](#); b) R. O. Dempcy and E. B. Skibo, [Bioorg. Med. Chem. Lett., 1993, 1, 39](#); c) K. Tereshima, H. Shimamura, A. Kawase, Y. Tanaka, T. Tanimura, T. Kamisaki, Y. Ishizuka, and M. Sato, [Chem. Pharm. Bull., 1995, 43, 2021](#); d) N. J. Liverton, D. J. Armstrong, D. A. Claremon, D. C. Remy, J. J. Baldwin, R. J. Lynch, G. Zhang, and R. Gould, [Bioorg. Med. Chem. Lett., 1998, 8, 483.](#)
242. a) S. Kobayashi, M. Ueno, R. Suzuki, and H. Ishitani, [Tetrahedron Lett., 1999, 40, 2175](#); b) S.-L. Cao, Y.-P. Feng, Y.-Y. Jiang, S.-Y. Liu, G.-Y. Ding, and R.-T. Li, [Bioorg. Med. Chem. Lett., 2005, 15, 1915](#); c) D. Gueyrard, V. Durnel, O. Leoni, S. Palmieri, and P. Rollin, [Heterocycles, 2000, 52, 827](#); d) B. Ana and S. Boteanu, [Farmacia, 1971, 19, 683](#); e) T. A. Martin, A. G. Wheller, R. F. Majewski, and J. R. Corrigan, [J. Med. Chem., 1964, 7, 812.](#)
243. a) K. Waisser, J. Gregor, H. Dostal, J. Kunes, L. Kubicova, V. Klimesova, and J. Kaustova, [Farmaco, 2001, 56, 803](#); b) J. Kunes, J. Bazant, M. Pour, K. Waisser, M. Slosarek, and J. Janota, [Farmaco, 2000, 55, 725.](#)
244. a) G. Rabillound and B. Sillion, [J. Heterocycl. Chem., 1980, 17, 1065](#); b) M. Okabe and R.-C. Sun, [Tetrahedron, 1995, 51, 1861](#); c) R. J. Abdel-Jalil, W. Voelter, and M. Saeed, [Tetrahedron Lett., 2004, 45, 3475](#); d) S. Xue, J. McKenna, W.-C. Shineh, and O. Repic, [J. Org. Chem., 2004, 69, 6474](#); e) B. Das and J. Benerjee, [Chem. Lett., 2004, 33, 960](#); f) J.-F. Liu, J. Lee, A. M. Dalton, G. Bi, L. Yu, C. M. Baldino, E. McElory, and M. Brown, [Tetrahedron Lett., 2005, 46, 1241.](#)
245. K. Okuro and H. Alper, [Tetrahedron Lett., 2012, 53, 2540.](#)
246. H. Alper and Z. Zheng, [Org. Lett., 2008, 10, 829.](#)

247. J. C. Chen, D. Wu, F. He, M. Liu, H. Wu, J. Ding, and W. Su, *Tetrahedron Lett.*, 2008, **49**, 3814.
248. Y. Shen, C. Han, S. Cai, P. Lu, and Y. Wang, *Tetrahedron Lett.*, 2012, **53**, 5671.
249. A. A. Mohammadi, M. Dabiri, and H. Qaraat, *Tetrahedron*, 2009, **65**, 3804.
250. M. M. Heravi, B. Baghernejad, and H. A. Oskooie, *Tetrahedron Lett.*, 2009, **50**, 767.
251. X. Xu, L. Liang, J. Liu, J. Yang, L. Mai, and Y. Li, *Tetrahedron Lett.*, 2009, **50**, 57.
252. T. Dahl, C. W. Tornøe, B. B. Andersen, P. Nielsen, and M. Jørgensen, *Angew. Chem. Int. Ed.*, 2008, **47**, 1726.
253. H. Zuo, Z.-B. Li, F.-K. Ren, J. R. Falck, M. Lijuan, C. Ahn, and D.-S. Shin, *Tetrahedron*, 2008, **64**, 9669.
254. B. Groenendaal, D. J. Vugts, R. F. Schmitz, F. J. J. de Kanter, E. Ruijter, M. B. Groen, and R. V. A. Orru, *J. Org. Chem.*, 2008, **73**, 719.
255. H. Zheng and D. G. Hall, *Tetrahedron Lett.*, 2010, **51**, 4256.
256. a) U. Nubbemeyer, *Synthesis*, 2003, 961; b) A. M. M. Castro, *Chem. Rev.*, 2004, **104**, 2939.
257. C.-X. Yan, Z.-X. Sun, and Y. Cheng, *Synthesis*, 2012, 865.
258. a) J. L. R. Martin, M. Sainz-Pardo, T. A. Furukawa, E. Martín-Sánchez, T. Seoane, and C. Galan, *J. Psychopharmacol.*, 2007, **21**, 774; b) S. Chakraborty, N. H. Shah, J. C. Fishbein, and R. S. Hosmane, *Bioorg. Med. Chem. Lett.*, 2011, **21**, 756; c) D. Antonow and D. E. Thurston, *Chem. Rev.*, 2011, **111**, 2815.
259. a) S. Michelini, G. B. Cassano, F. Frare, and G. Perugi, *Pharmacopsychiatry*, 1996, **29**, 127; b) J. Knabe, H. P. Buech, and S. Bender, *Arch. Pharm. (Weinheim)*, 1995, **328**, 59; c) R. N. Brogden, R. C. Heel, T. M. Speight, and G. S. Avery, *Drugs*, 1980, **20**, 161; d) K. S. Atwal, J. L. Bergey, A. Hedberg, and S. Moreland, *J. Med. Chem.*, 1987, **30**, 635; e) V. Merluzzi, K. D. Hargrave, M. Labadia, K. Grozinger, M. Skoog, J. C. Wu, C.-K. Shih, K. Eckner, S. Hattox, J. Adams, A. S. Rosenthal, R. Faanes, R. J. Eckner, R. A. Koup, and J. L. Sullivan, *Science*, 1990, **250**, 1411; f) M. D. Braccio, G. Grossi, G. Roma, L. Vargiu, M. Mura, and M. E. Marongiu, *Eur. J. Med. Chem.*, 2001, **36**, 935; g) K. A. Parker and C. A. Coburn, *J. Org. Chem.*, 1992, **57**, 97.
260. A. Maleki, *Tetrahedron*, 2012, **68**, 7827.
261. a) B. Willy, T. Dallos, F. Rominger, J. Schönhaber, and T. J. J. Müller, *Eur. J. Org. Chem.*, 2008, 4796; b) S. S. Palimkar, R. J. Lahoti, and K. V. Srinivasan, *Green Chem.*, 2007, **9**, 146.
262. M. Nardi, A. Cozza, A. De Nino, M. Oliverio, and A. Procopio, *Synthesis*, 2012, 800.
263. I. R. Siddiqui, S. Shamim, D. K. Shireen, and M. A. Waseem, *New J. Chem.*, 2012, **36**, 2209.
264. R. A. De Silva, S. Santra, and P. R. Andreana, *Org. Lett.*, 2008, **10**, 4541.
265. C. Hudson, V. S. Murthy, K. G. Esetep, and G. Gustafson, *Tetrahedron Lett.*, 2007, **48**, 1489.
266. X. Yi, B.-D. Barry, P. Liao, and X. Bi, *Synthesis*, 2012, 1323.

267. J. Barluenga, A. Mendoza, F. Rodriguez, and F. J. Fananas, [\*Angew. Chem.\*, 2008, \*\*120\*\*, 7152](#); [\*Angew. Chem. Int. Ed.\*, 2008, \*\*47\*\*, 7044](#).
268. J. Barluenga, A. Mendoza, F. Rodríguez, and F. J. Fañanás, [\*Angew. Chem.\*, 2009, \*\*121\*\*, 1672](#); [\*Angew. Chem. Int. Ed.\*, 2009, \*\*48\*\*, 1644](#).
269. Y. Ohta, H. Chiba, S. Oishi, N. Fujii, and H. Ohno, [\*Org. Lett.\*, 2008, \*\*10\*\*, 3535](#).
270. Y. Ohta, S. Oishi, N. Fujii, and H. Ohno, [\*Org. Lett.\*, 2009, \*\*11\*\*, 1979](#).
271. Y. Ohta, Y. Kubota, T. Watabe, H. Chiba, S. Oishi, N. Fujii, and H. Ohno, [\*J. Org. Chem.\*, 2009, \*\*74\*\*, 6299](#).
272. F. Zeng and H. Alper, [\*Org. Lett.\*, 2010, \*\*12\*\*, 3642](#).
273. A. Kapur, K. Kumar, L. Singh, P. Singh, M. Elango, V. Subramanian, V. Gupta, P. Kanwal, and M. P. S. Ishar, [\*Tetrahedron\*, 2009, \*\*65\*\*, 4593](#).
274. S. H. S. Azzam and M. A. Pasha, [\*Tetrahedron Lett.\*, 2012, \*\*53\*\*, 6834](#).
275. H. Mecadon, M. R. Rohman, M. Rajbangshi, and B. Myrboh, [\*Tetrahedron Lett.\*, 2011, \*\*52\*\*, 2523](#).
276. X. Yu, G. Qiu, J. Liu, and J. Wu, [\*Synthesis\*, 2011, 2268](#).
277. A. Zamudio-Medina, M. C. García-González, J. Padilla, and E. González-Zamora, [\*Tetrahedron Lett.\*, 2010, \*\*51\*\*, 4837](#).
278. A. Kumar, A. Saxena, M. Dewan, A. De, and S. Mozumdar, [\*Tetrahedron Lett.\*, 2011 \*\*52\*\*, 4835](#).
279. E. Mosaddegh and A. Hassankhani, [\*Tetrahedron Lett.\*, 2011, \*\*52\*\*, 488](#).
280. S.-H. Song, J. Zhong, Y.-H. He, and Z. Guan, [\*Tetrahedron Lett.\*, 2012, \*\*53\*\*, 7075](#).
281. B. V. S. Reddy, C. Divyavani, Z. Begum, J. S. Yadav, and T. P. Rao, [\*Synthesis\*, 2011, 168](#).
282. J. Cheng, X. Jiang, and S. Ma, [\*Org. Lett.\*, 2011, \*\*13\*\*, 5200](#).
283. O. A. Attanasi, S. Bartoccini, G. Favi, G. Giorgi, F. R. Perrulli, and S. Santeusanio, [\*J. Org. Chem.\*, 2012, \*\*77\*\*, 1161](#).
284. R. Ghahremanzadeh, T. Amanpour, and A. Bazgir, [\*Tetrahedron Lett.\*, 2010, \*\*51\*\*, 4202](#).



Dr. Pradip Kumar Maji was born in Burdwan, India. He received his B.Sc. (2000) and M. Sc. (2002) degrees from Visva-Bharati University, Santiniketan. He received his PhD degree in 2008 from the University of Kalyani (with Prof. K. C. Majumdar). He joined the Department of Chemistry at Bidhan Chandra College, Asansol, West Bengal in 2006 as an Assistant Professor. His research interests are focused on: the discovery of new methodologies, metal catalysis in multicomponent reaction towards heterocycles and green chemistry.



Dr. Rafique Ul Islam completed his M.Sc. (Chemistry) degree in 2001 from Cotton College, Guwahati and completed PhD degree in the year 2007 in Chemistry from the University of Kalyani, West Bengal, India. After finishing his postdoctoral research at University of the Witwatersrand, Johannesburg, South Africa, he joined as an Assistant Professor at the Department of Applied Chemistry, Birla Institute of Technology, Mesra, Ranchi, India in September 2009. His research interest covers metal-nanocomposite materials and catalysis, metal-catalyzed multicomponent reaction, and synthesis of heterocyclic compounds. Dr. Islam has co-authored in 24 publications in peer reviewed international journals, two chapters in books.



Dr. Sujit Kumar Bera was born in Burdwan, India. He received his B.Sc. (1997) and M. Sc. (1999) degrees from University of Burdwan. He received his PhD degree in 2004 from the same University (with Prof. G. S. De and Dr. S. K.Chandra). He joined the Department of Chemistry at Bidhan Chandra College, Asansol, West Bengal in 2007 as an Assistant Professor. His research interests are focused on: synthesis of metal catalyst and spectral properties of lanthanide complexes.