

HETEROCYCLES, Vol. 90, No. 1, 2015, pp. 540 - 562. © 2015 The Japan Institute of Heterocyclic Chemistry
Received, 30th June, 2014, Accepted, 16th July, 2014, Published online, 22nd July, 2014
DOI: 10.3987/COM-14-S(K)57

Mn(III)-BASED OXIDATIVE CYCLIZATION OF N-ARYL-3-OXOBUTANAMIDES. FACILE SYNTHESIS AND TRANSFORMATION OF SUBSTITUTED OXINDOLES[†]

Nobutaka Kikue, Tetsuya Takahashi, and Hiroshi Nishino*

Department of Chemistry, Graduate School of Science and Technology,
Kumamoto University, Kurokami 2-39-1, Chûou-Ku, Kumamoto 860-8555,
Japan

Fax: +81-96-342-3374; E-mail: nishino@sci.kumamoto-u.ac.jp

[†]Dedicated to Prof. Dr. Isao Kuwajima, Professor emeritus of Tokyo Institute of Technology, on his 77th birthday

Abstract – The oxidation of 3-oxo-*N*-phenylbutanamides **1** with manganese(III) acetate in ethanol afforded dimeric 3,3'-biindoline-2,2'-dione derivatives **3–5**. A similar reaction of *N*,2-disubstituted *N*-aryl-3-oxobutanamides **6** in acetic acid produced 3-acetylidolin-2-ones **7** bearing various substituents in good to excellent yields. The acetylidolinones **7** were easily deacetylated by treatment using neutral alumina in diethyl ether. Both the acetylidolinones **7** and deacetylated indolinones **8** were transformed by reduction into the substituted 1*H*-indoles.

INTRODUCTION

Many of the chemistries for indoles and their derivatives have been investigated and reported.¹ However, the synthesis and reaction of these heterocycles are still attractive from the view point of the synthetic method,² total synthesis of natural products,³ biological and pharmacological activities,^{1b,4} and material science.⁵ Recently, we reported the Mn(III)-mediated direct substitution of methoxynaphthalenes with *N*-aryl-3-oxobutanamides, giving the 3-oxobutanamide-substituted naphthalene **I** in addition to a small amount of demethoxylated naphthofuran **II** and benzoindolinone **III** (Scheme 1, eq. 1).⁶ Although the yield of the heterocyclic compounds **II** and **III** was poor, the carbon-carbon bond formation efficiently occurred during the reaction.⁷ We also reported the facile synthesis of 3,4-dihydro-2(1*H*)-quinolinones,

such as **IV**, by the Mn(III)-based oxidative cyclization of 2-(2-arylamino-2-oxoethyl)malonates (Scheme 1, eq. 2).⁸ In the reaction, the formal 6-*endo-trig*-type cyclization (cyclization at the *ortho* position) was superior to the formal 5-*exo-trig*-type (*ipso*-cyclization) except for the case of the malonates bearing an electron-rich aryl group, producing spiro compounds, such as **V**. It is also known that 2'-hydroxychalcone undergoes the 5-*exo-trig* cyclization to afford the aurone.⁹ In either event, it shows that the construction of heterocycles using the Mn(III)-based carbon-carbon bond formation is convenient.¹⁰ In order to favor the 5-*exo-trig* cyclization using the reaction, *N*-aryl-3-oxobutanamides **1** should be the most appropriate candidate for the synthesis of nitrogen heterocycles, such as oxindoles (indolin-2-ones). It prompted us to investigate this reaction. In this paper, we describe the facile synthesis of substituted indolin-2-ones using the Mn(III)-based oxidation of *N*-aryl-3-oxobutanamides and transformation into the corresponding 1*H*-indoles.

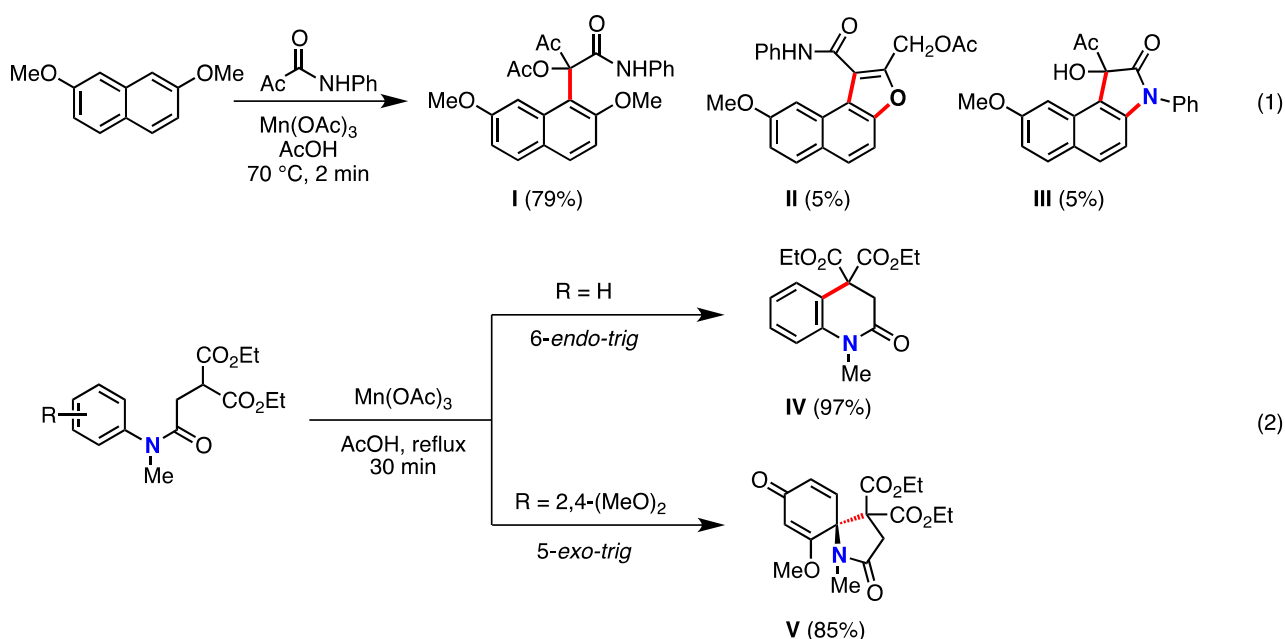

Scheme 1. Carbon-Carbon Bond Formation Using Mn(III)-Based Oxidation

RESULTS AND DISCUSSION

We first prepared the 3-oxo-*N*-phenylbutanamides **1a-c** from the reaction of the corresponding anilines with diketene, and examined the reaction with manganese(III) acetate, Mn(OAc)₃ (Scheme 2). The reaction was carried out in acetic acid at reflux temperature similar to the oxidation of malonates as shown in Scheme 1, eq. 2.⁸ Although the oxidation finished within 2-3 minutes along with some recovery of the unchanged 3-oxobutanamides **1**, the reaction was very complicated and none of the desired indolinones were detected. The formation of the Mn(III)-enolate complex with **1** would possibly be fast

and successive electron transfer should easily occur,^{10a,11} so that the oxidation would cause α -cleavage of the amide bond to produce polymeric compounds.¹² In order to recognize the oxidative radical reaction, the reaction was conducted in the presence of 1,1-diphenylethene as a radical trapping reagent, and 2-methyl-*N*,5,5-triphenyl-4,5-dihydrofuran-3-carboxamide **VI** could be obtained (Scheme 2 and also see the Experimental Section). Since the radical trapping product **VI** was confirmed, we investigated the reaction of **1b** (R = Me) in neutral solvent, such as ethanol, to decrease the reaction rate.^{10a,13} Although the reaction did not proceed at room temperature for 2 days, the oxidation occurred at elevated temperature and the dimeric indolin-2-ones **3**, **4**, and **5** were obtained (Scheme 2). Unfortunately, dimerization of the indolinone intermediate **2b** could not be controlled under the various reaction conditions.

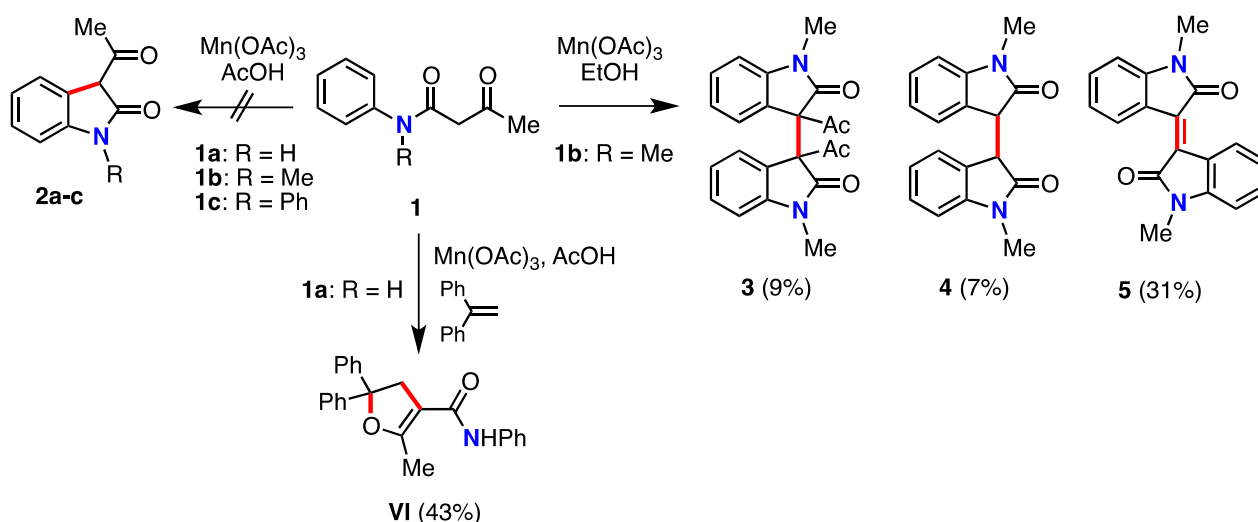

Scheme 2. Reaction of 3-Oxo-*N*-phenylbutanamides **1a–c** with Mn(OAc)₃

The results suggested that the formation of the Mn(III)-enolate complex with both **1b** and **2b** was still fast in ethanol and the indolinone **2b** was sufficiently reactive to dimerize under the stated conditions. However, we were able to isolate the cyclization products **3–5** even in low yields using the Mn(III)-based oxidation. In order to prevent the dimerization, we next explored the reaction using 3-oxo-*N*-phenylbutanamides bearing a substituent at the 2-position. We selected *N*,2-dimethyl-*N*-phenyl-3-oxobutanamide (**6a**), prepared by the methylation of **1b**, and the reaction was carried out under the above conditions in ethanol, producing the desired 3-acetyl-1,3-dimethylindolin-2-one (**7a**) (Scheme 3). A stoichiometric amount of the oxidant was consumed within 12 minutes and the product **7a** was obtained in 71% yield (Table 1, Entry 1). Surprisingly, separation using a neutral alumina column after the reaction led to the deacetylation product **8a** (Entries 2, 3) (vide infra). The reaction in propanol did not proceed (Entry 4). However, when the

reaction was conducted in glacial acetic acid, the oxidant was consumed within 3 minutes and the acetylindolinone **7a** was quantitatively produced (Entry 5). The structure of **7a** was easily characterized by disappearance of the quartet of methine proton and the collapsing of a doublet of the methyl group at the C-2 position of **6a** to a singlet of the corresponding methyl group of **7a** in the ^1H NMR spectrum (see Experimental section).

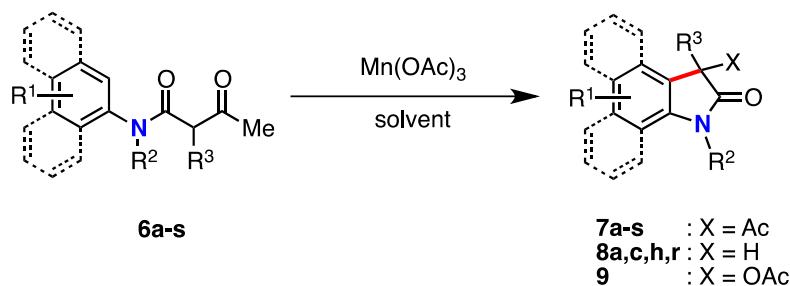

Scheme 3. Oxidation of *N*,2-Dialkyl-*N*-aryl-3-oxobutanamides **6a-s** with Mn(OAc)_3

With the efficient oxidative cyclization in hand, we applied the reaction to various substituted 3-oxobutanamides **6b-s** in order to examine the substituent effect (Scheme 3 and Table 1, Entries 6-35). Introduction of a deactivating group toward an electrophile, such as a halogen atom in R^1 on the aromatic ring, led to prolonging the reaction time (Table 1, Entries 6, 8, 9). On the other hand, an activating group in R^1 tended to be similar or shortened the reaction time (Entries 10–12, 15, 16). In both cases, indolinones **7b-i** were produced in high to quantitative yields. An *N*-alkyl or *N*-phenyl- substituent in R^2 did not influence the cyclization, but all of **6j-m** gave the corresponding indolinones **7j-m** in high yields (Entries 17–20). When butanamide **6n** bearing an ethyl group in R^3 at the 2-position of the 3-oxobutanamide underwent the reaction under similar conditions, indolinone **7n** was obtained in a moderate yield together with the unchanged **6n** (Entry 21). Use of an excess amount of the oxidant led to the production of **7n** in an almost quantitative yield (Entry 23). However, it took a longer reaction time to consume the oxidant. This tendency was also observed in the reaction of **6o** ($\text{R}^3 = \text{propyl}$), **6p** ($\text{R}^3 = i\text{-propyl}$), and **6q** ($\text{R}^3 = \text{butyl}$) (Entries 24–30). In the case of butylbutanamide **6q**, the use of a large amount of the oxidant resulted in deacetylation followed by overoxidation to afford 3-acetoxy-3-butyl-1-methylindolin-2-one (**9**) (Entries 29, 30). *N*-Naphthylbutanamides **6r** and **6s** also produced the corresponding benzoindolinones **7r** and **7s** in excellent yields (Entries 33, 35).

Most of the reactions proceeded in acetic acid for 3–6 minutes using a stoichiometric amount of Mn(OAc)_3 to give the corresponding indolinones **7**. The plausible mechanism for the formation of **7** is outlined in Scheme 4. The rate-determining step would be the stage (**6** \rightarrow **A**) for the formation of the Mn(III)-enolate complex **A**.^{10a,11} Therefore, the bulky alkyl group of substituent R^3 made the reaction rate

slower and a steric hindrance derived from the bulkiness inhibited the cyclization affording the intermediate radical **B**. In order to accelerate the reaction, an excess amount of the oxidant would be necessary (Entries 23, 25, 27, 29).

Table 1. Mn(III)-Based Oxidation of *N*,2-Dialkyl-*N*-aryl-3-oxobutanamides **6a-s**^a

Entry	R ¹	R ²	R ³	6 :Mn(OAc) ₃ ^b	Solvent	Time/min	Product (yield/%) ^c	Rec. 6 ^d
1	6a	H	Me	Me	1:2	EtOH	12	7a (71)
2	6a					EtOH	12	8a (68) ^e
3	6a					MeOH	45	8a (99) ^e
4	6a					PrOH	240	100
5	6a					AcOH	3	7a (quant)
6	6b	4-F	Me	Me	1:2	AcOH	6	7b (99)
7	6c	4-Cl	Me	Me	1:2	EtOH	30	8c (31) ^e
8	6c	4-Cl	Me	Me	1:2	AcOH	6	7c (quant)
9	6d	2-Cl	Me	Me	1:2	AcOH	6	7d (quant)
10	6e	4-Me	Me	Me	1:2	AcOH	3	7e (quant)
11	6f	2-Me	Me	Me	1:2	AcOH	3	7f (94)
12	6g	4-MeO	Me	Me	1:2	AcOH	2	7g (89)
13	6h	3-MeO	Me	Me	1:2	EtOH	9	8h (53) ^e
14	6h	3-MeO	Me	Me	1:2	MeOH	40	8h (76) ^e
15	6h	3-MeO	Me	Me	1:2	AcOH	2	7h (83) ^f
16	6i	2-MeO	Me	Me	1:2	AcOH	3	7i (89)
17	6j	H	Et	Me	1:2	AcOH	3	7j (96)
18	6k	H	Bu	Me	1:2	AcOH	4	7k (98)
19	6l	H	<i>i</i> -Pr	Me	1:2	AcOH	3	7l (93)
20	6m	H	Ph	Me	1:2	AcOH	2	7m (91)
21	6n	H	Me	Et	1:2	AcOH	3	7n (46)
22	6n				1:3		4	7n (64)
23	6n				1:4		19	7n (98)
24	6o	H	Me	Pr	1:2	AcOH	3	7o (57)
25	6o				1:4	AcOH	8	7o (94)
26	6p	H	Me	<i>i</i> -Pr	1:2	AcOH	5	7p (3)
27	6p				1:4	AcOH	13	7p (4)
28	6q	H	Me	Bu	1:2	AcOH	5	7q (80)
29	6q				1:4		15	7q (81)
30	6q				1:6		60	7q (40)
31	6r	1-Naph ^g	Me	Me	1:2	EtOH	360	8r (63) ^e
32	6r				1:2	AcOH	6	7r (73)
33	6r				1:3	AcOH	10	7r (96)
34	6s	2-Naph ^g	Me	Me	1:2	AcOH	8	7s (79)
35	6s				1:3	AcOH	10	7s (99)

^a The reaction of **6** (0.5 mmol) was carried out in solvent (15 mL) at reflux temperature in air.

^b Molar ratio.

^c The yield was based on the amount of the 3-oxobutanamide **6** used.

^d Recovery.

^e The separation was performed by neutral Al₂O₃ eluting with Et₂O–hexane (7:3 v/v).

^f The regioisomer ratio was 6-MeO-**7h**:4-MeO-**7h** = 1.8:1.

^g The naphthyl group was represented as *N*-aryl group substituted by R¹ of **6** in Scheme 3.

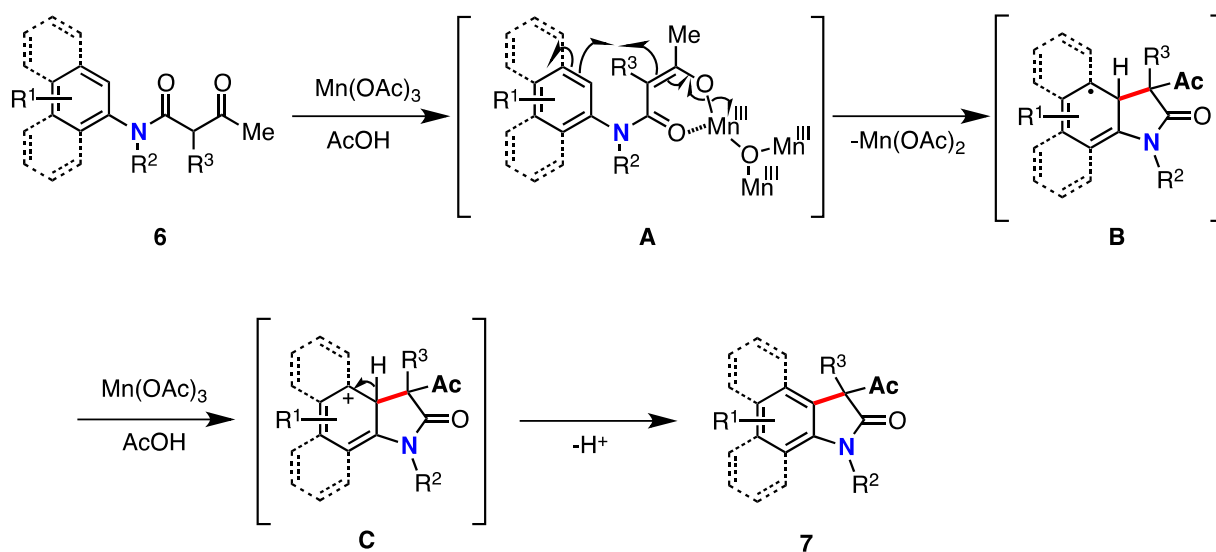

Scheme 4. Plausible Mechanism for the Formation of Indolinones **7**

We unexpectedly found the deacetylation during the separation and purification of the acetylindolinones **7** through a neutral alumina column (Table 1, Entries 2, 3, 7, 13, 14, 31). We were interested in the facile deacetylation affording indolinones **8**, so that we scrutinized the reaction (Scheme 5). When acetylindolinone **7a** ($R^1 = \text{H}$) was treated in aqueous acetic acid, or acetic acid in the presence of $\text{Mn(OAc)}_2 \cdot 4\text{H}_2\text{O}$, or in diethyl ether alone at 23 °C to reflux temperature, no reaction occurred and **7a** was recovered unchanged (Table 2, Entries 1–3). However, when neutral alumina was added to **7a** in diethyl ether and the mixture was stirred at room temperature in a flask, the deacetylation somewhat proceeded (Entry 4). After optimizing the reaction, a quantitative yield of **8a** was achieved within 1 hour in diethyl ether (Entry 7). Methanol instead of diethyl ether as the solvent was not effective for the deacetylation (Entry 8). Other acetylindolinones **7b** and **7g** also underwent the deacetylation to give similar results (Entries 9, 10).

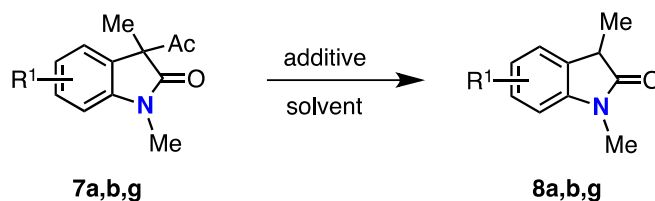

Scheme 5. Deacetylation of 3-Acetyl-1,3-dimethylindolin-2-ones **7a, b, g**

Table 2. Deacetylation of 3-Acetyl-1,3-dimethylindolin-2-ones **7a, b, g**^a

Entry	R ¹	Solvent	Additive	Time/h	Temp	Product (yield/%) ^b	Rec. ⁷ ^c	
1	7a	H	AcOH	H ₂ O 2 mL	0.25	rt to reflux	100	
2	7a	AcOH	Mn(OAc) ₂	0.25 g	0.25	rt to reflux	100	
3	7a	Et ₂ O	none		1	rt to reflux	100	
4	7a	Et ₂ O	Al ₂ O ₃	0.5 g	1	rt	8a (18)	
5	7a			0.5 g	12	reflux	8a (51)	
6	7a			1.5 g	1	rt	8a (61)	
7	7a			7 g	1	rt	8a (quant)	
8	7a	MeOH	Al ₂ O ₃	7 g	1	rt	100	
9	7b	5-F	Et ₂ O	Al ₂ O ₃	7 g	1	rt	8b (72)
10	7g	5-MeO	Et ₂ O	Al ₂ O ₃	7 g	1	rt	8g (96)

^a The reaction of **7** (0.5 mmol) was carried out in solvent (15 mL).

^b The yield was based on the amount of the dimethylindolinone **7** used.

^c Recovery.

Although some methods are known for the transformation into indoles,¹⁴ we finally investigated the convenient route to substituted indoles from indolinones. With deacetylated indolinones **8** in hand, we examined the reduction of **8**.¹⁵ The reaction using LiAlH₄ (LAH) was carried out in dry tetrahydrofuran (THF) at 0 °C for 1 hour, then at room temperature for 4 hours, giving the desired indole **10a** (Scheme 6). Since the reduction was quite easy, we tried to directly reduce the acetylindolinone **7a** under the same conditions. Fortunately, the reduction efficiently proceeded and the desired indole **10a** was produced in good yield. The reduction of the other indolinones **7b, g** and **8b, g** also gave similar results (Scheme 6).

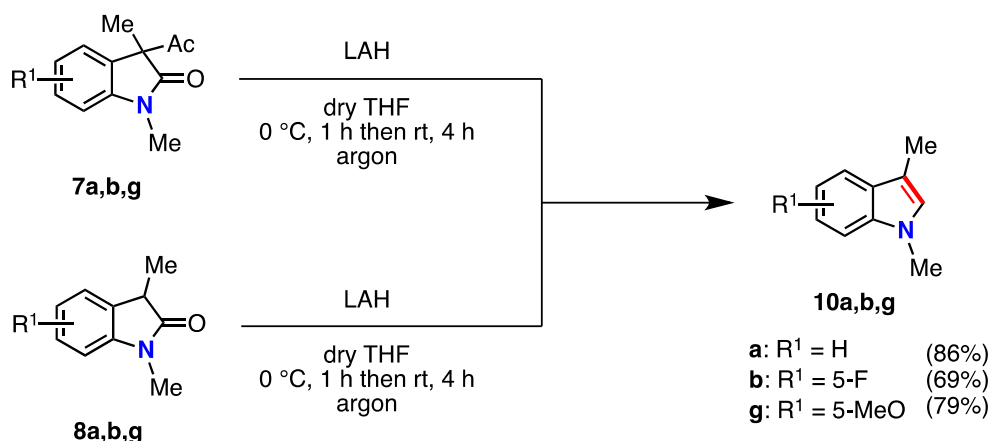
**Scheme 6.** Reduction of Indolin-2-ones **7** and **8** with LAH

CONCLUSION

We demonstrated the facile synthesis of 3-acetylindolin-2-ones **7** using a stoichiometric amount of Mn(OAc)₃ in most cases, with a short reaction time and in high to quantitative yields, and also a simple

retro-Claisen-like deacetylation of **7** by stirring with neutral alumina in diethyl ether at room temperature. In addition, both the 3-acetylundolinones **7** and the deacetylated **8** were easily transformed by normal LAH reduction into the corresponding indoles **10**. Although some skillful methods for the synthesis of indolinones were recently reported,¹⁶ to the best of our knowledge, the Mn(III)-based oxidative cyclization of 3-oxobutanamides is one of the simplest and most convenient methods for the synthesis of substituted indolinone derivatives.

EXPERIMENTAL

Measurements. Melting points were taken using a Yanagimoto micromelting point apparatus and are uncorrected. The NMR spectra were recorded using a JNM AL300 or ECX 500 FT-NMR spectrometer at 300 or 500 MHz for ^1H and at 75 or 125 MHz for ^{13}C , with tetramethylsilane as the internal standard. The chemical shifts are reported in δ values (ppm) and the coupling constants in Hz. The IR spectra were measured in CHCl_3 or KBr using a Shimadzu 8400 FT IR spectrometer and expressed in cm^{-1} . The EI MS spectra were obtained by a Shimadzu QP-5050A gas chromatograph-mass spectrometer at the ionizing voltage of 70 eV. The high-resolution mass spectra and the elemental analyses were performed at the Instrumental Analysis Center, Kumamoto University, Kumamoto, Japan.

Materials. Manganese(II) acetate tetrahydrate, $\text{Mn}(\text{OAc})_2 \cdot 4\text{H}_2\text{O}$, was purchased from Wako Pure Chemical Ind., Ltd. Manganese(III) acetate dihydrate, $\text{Mn}(\text{OAc})_3 \cdot 2\text{H}_2\text{O}$, was prepared according to the modified method described in the literature (vide infra).^{17,18} Aniline and the substituted anilines from Wako Pure Chemical Ind., Ltd., naphthylamines from Kanto Chemical Co., Inc., and diketene and lithium aluminum hydride from Tokyo Kasei Co., Ltd., were purchased and used as received. The *N*-methylanilines were prepared by condensation of the corresponding anilines with paraformaldehyde in the presence of sodium methoxide in methanol followed by reduction with sodium borohydride. The other *N*-alkylanilines were purchased from Sigma-Aldrich Co., LLC. The *N*,2-dialkyl-3-oxobutanamides **6a-s** were prepared by the reaction of neat *N*-alkylanilines with diketene followed by alkylation of the alkyl bromides in the presence of sodium hydride in dry tetrahydrofuran (THF). Flash column chromatography was performed on silica gel 60N (40-50 mm), which was purchased from Kanto Chemical Co., Inc., and thin layer chromatography (TLC) on Wakogel B-10 (45 mm) from Wako Pure Chemical Ind., Ltd. The activated neutral aluminum oxide (Al_2O_3) was purchased from Sigma-Aldrich Co., LLC.

Modified Preparation of Manganese(III) Acetate Dihydrate.^{17,18} To a 2 L round-bottomed flask, $\text{Mn}(\text{OAc})_2 \cdot 4\text{H}_2\text{O}$ (66 g, 0.27 mol) and glacial AcOH (660 mL) were added and the mixture was heated at 90 °C to dissolve the components (normally for 10-30 min). *The mixture must not be heated under reflux.* After cooling, acetic anhydride (96 mL) was added to the mixture with stirring. Three portions of **ground**

potassium permanganate, KMnO_4 , (11 g, 0.07 mol) were then slowly added with stirring. The mixture was heated under reflux for 1 h (**Caution:** the added KMnO_4 must be dissolved in the reaction mixture. Otherwise the reaction mixture could be bumpy while cooling on the bench! *Very dangerous!*). After cooling, water (110 mL) was added and the mixture was kept at room temperature under dark conditions until the dark color of the supernatant solution turned transparent normally within for 2 weeks. The crystalline manganese(III) acetate formed was filtered, washed three times with glacial AcOH, washed twice with dried Et_2O , and dried in a desiccator under reduced pressure using KOH as a drying agent, resulting in the bright-brown color of $\text{Mn}(\text{OAc})_3 \cdot 2\text{H}_2\text{O}$ (67 g, 93% yield).

***N*,2-Dimethyl-3-oxo-*N*-phenylbutanamide (6a).**^{16j,19} Yield 96%. Yellow liquid. IR (CHCl_3): ν 1724 (C=O), 1651 (CONH) cm^{-1} . ^1H NMR (300 MHz, CDCl_3): δ 7.49-7.36 (3H, m, arom H), 7.27-7.19 (2H, m, arom H), 3.41 (1H, q, $J = 6.9$ Hz, CH), 3.31 (3H, s, NMe), 2.02 (3H, s, Ac), 1.27 (3H, d, $J = 6.9$ Hz, Me) ppm. ^{13}C NMR (75 MHz, CDCl_3): δ 204.9 (C=O), 170.6 (N-C=O), 143.5, 130.1, 128.4, 127.5 (arom C), 51.6 (CH), 37.6 (N-Me), 27.9 (Ac), 13.9 (Me) ppm. HRMS (acetone/NBA) calcd for $\text{C}_{12}\text{H}_{16}\text{NO}_2$ 206.1181 (M+H). Found 206.1185.

***N*-(4-Fluorophenyl)-*N*,2-dimethyl-3-oxobutanamide (6b).** Yield 92%. Orange liquid. IR (CHCl_3): ν 1719 (C=O), 1653 (CONH) cm^{-1} . ^1H NMR (300 MHz, CDCl_3): δ 7.22-7.10 (4H, m, arom H), 3.37 (1H, q, $J = 6.9$ Hz, CH), 3.28 (3H, s, N-Me), 2.03 (3H, s, Ac), 1.27 (3H, d, $J = 6.9$ Hz, Me) ppm. ^{13}C NMR (75 MHz, CDCl_3): δ 204.9 (C=O), 170.6 (N-C=O), 163.7, 160.4, 139.5, 129.5, 129.4, 117.2, 116.9 (arom C), 51.6 (CH), 37.8 (N-Me), 27.9 (Ac), 14.0 (Me) ppm. FAB HRMS (acetone/NBA) calcd for $\text{C}_{12}\text{H}_{15}\text{FNO}_2$ 224.1087 (M+H). Found 224.1089.

***N*-(4-Chlorophenyl)-*N*,2-dimethyl-3-oxobutanamide (6c).** Yield 91%. Yellow liquid. IR (CHCl_3): ν 1724 (C=O), 1655 (CONH) cm^{-1} . ^1H NMR (300 MHz, CDCl_3): δ 7.44-7.41 (2H, m, arom H), 7.17-7.14 (2H, m, arom H), 3.38 (1H, q, $J = 7.2$ Hz, CH), 3.28 (3H, s, NMe), 2.05 (3H, s, Ac), 1.28 (3H, d, $J = 7.2$ Hz, Me) ppm. ^{13}C NMR (75 MHz, CDCl_3): δ 204.8 (C=O), 170.4 (N-C=O), 142.0, 134.3, 130.3, 128.9 (arom C), 51.6 (CH), 37.7 (N-Me), 27.9 (Ac), 14.0 (Me) ppm. HRMS (acetone/NBA) calcd for $\text{C}_{12}\text{H}_{15}\text{ClNO}_2$ 240.0791 (M+H). Found 240.0797.

***N*-(2-Chlorophenyl)-*N*,2-dimethyl-3-oxobutanamide (6d).** Rotamer ratio = 1.28:1. Yield quant. Colorless liquid. IR (CHCl_3): ν 1716 (C=O), 1655 (CONH) cm^{-1} . ^1H NMR (500 MHz, CDCl_3): δ 7.58-7.53 (1H, m, arom H), 7.42-7.28 (3H, m, arom H), 3.26, 3.25 (3H, s, Me), 3.24-3.16 (1H, m, CH), 2.19, 2.01 (3H, s, Ac), 1.33, 1.23 (3H, d, $J = 6.9$ Hz, Me) ppm. ^{13}C NMR (125 MHz, CDCl_3): δ 205.0, 203.5 (C=O), 171.2, 170.1 (N-C=O), 140.33, 140.32, 132.9, 132.7, 130.9, 130.6, 130.0, 129.9, 129.7, 128.4 (arom C), 51.8, 51.4 (CH), 36.1, 36.0 (N-Me), 28.0, 27.6 (Ac), 13.9, 13.6 (Me) ppm. FAB HRMS (acetone/NBA) calcd for $\text{C}_{12}\text{H}_{15}\text{ClNO}_2$ 240.0791 (M+H). Found 240.0802.

***N*-(4-Methylphenyl)-*N*,2-dimethyl-3-oxobutanamide (6e).**^{16j} Yield 73%. Yellow liquid. IR (CHCl₃): ν 1720 (C=O), 1651 (CONH) cm⁻¹. ¹H NMR (300 MHz, CDCl₃): δ 7.27-7.23 (2H, m, arom H), 7.09-7.06 (2H, m, arom H), 3.41 (1H, q, J = 6.9 Hz, CH), 3.28 (3H, s, N-Me), 2.39 (3H, s, Me), 2.03 (3H, s, Ac), 1.25 (3H, d, J = 6.9 Hz, Me) ppm. ¹³C NMR (75 MHz, CDCl₃): δ 204.9 (C=O), 170.8 (N-C=O), 140.1, 138.4, 130.7, 127.2 (arom C), 51.5 (CH), 37.7 (N-Me), 27.9 (Ac), 21.1 (Me), 13.9 (Me) ppm. FAB HRMS (acetone/NBA) calcd for C₁₃H₁₈NO₂ 220.1338 (M+H). Found 220.1337.

***N*-(2-Methylphenyl)-*N*,2-dimethyl-3-oxobutanamide (6f).**^{16j} Rotamer ratio = 1.24:1. Yield 84%. Brown liquid. IR (CHCl₃): ν 1720 (C=O), 1651 (CONH) cm⁻¹. ¹H NMR (500 MHz, CDCl₃): δ 7.33-7.24 (3H, m, arom H), 7.12-7.10 (1H, m, arom H), 3.29-3.18 (1H, m, CH), 3.23, 3.22 (3H, s, NMe), 2.28, 2.23 (3H, s, Me), 2.03, 2.00 (3H, s, Ac), 1.28, 1.26 (3H, d, J = 6.9 Hz, Me) ppm. ¹³C NMR (125 MHz, CDCl₃): δ 205.0, 204.7 (C=O), 171.1, 170.5 (N-C=O), 141.8, 141.7, 135.9, 135.4, 131.9, 131.6, 128.8, 128.7, 128.5, 128.1, 127.6, 127.4 (arom C), 51.54, 51.52 (CH), 36.3 (N-Me), 27.9, 27.8 (Ac), 17.4, 17.3 (Me), 14.3, 14.1 (Me) ppm. Anal. Calcd for C₁₃H₁₇NO₂: C, 71.21; H, 7.81; N, 6.39. Found: C, 71.18; H, 8.02; N, 6.27.

***N*-(4-Methoxyphenyl)-*N*,2-dimethyl-3-oxobutanamide (6g).** Yield 62%. Orange liquid. IR (CHCl₃): ν 1720 (C=O), 1651 (CONH) cm⁻¹. ¹H NMR (300 MHz, CDCl₃): δ 7.14-7.09 (2H, m, arom H), 6.96-6.91 (2H, m, arom H), 3.82 (3H, s, OMe), 3.42 (1H, q, J = 6.9 Hz, CH), 3.27 (3H, s, N-Me), 2.03 (3H, s, Ac), 1.26 (3H, d, J = 6.9 Hz, Me) ppm. ¹³C NMR (75 MHz, CDCl₃): δ 205.0 (C=O), 171.0 (N-C=O), 159.3, 136.2, 128.6, 115.1 (arom C), 55.5 (OMe), 51.5 (CH), 37.8 (N-Me), 28.0 (Ac), 13.9 (Me) ppm. FAB HRMS (acetone/NBA) calcd for C₁₃H₁₈NO₃ 236.1287 (M+H). Found 236.1288.

***N*-(3-Methoxyphenyl)-*N*,2-dimethyl-3-oxobutanamide (6h).** Yield 86%. Yellow liquid. IR (CHCl₃): ν 1720 (C=O), 1651 (CONH) cm⁻¹. ¹H NMR (300 MHz, CDCl₃): δ 7.38-7.33 (1H, m, arom H), 6.94-6.90 (1H, m, arom H), 6.81-6.73 (2H, m, arom H), 3.83 (3H, s, OMe), 3.46 (1H, q, J = 6.0 Hz, CH), 3.30 (3H, s, NMe), 2.05 (3H, s, Ac), 1.27 (3H, d, J = 6.0 Hz, Me) ppm. ¹³C NMR (75 MHz, CDCl₃): δ 204.9 (C=O), 170.6 (N-C=O), 160.7, 144.6, 130.8, 119.5, 113.7, 113.4 (arom C), 55.5 (OMe), 51.2 (CH), 37.5 (NMe), 28.0 (Ac), 14.0 (Me) ppm. HRMS (acetone/NBA) calcd for C₁₃H₁₈NO₃ 236.1287 (M+H). Found 236.1282.

***N*-(2-Methoxyphenyl)-*N*,2-dimethyl-3-oxobutanamide (6i).** Rotamer ratio = 1.37:1. Yield 58%. Colorless microcrystals (from EtOH), mp 66-67 °C. IR (CHCl₃): ν 1720 (C=O), 1651 (CONH) cm⁻¹. ¹H NMR (300 MHz, CDCl₃): δ 7.38-7.34 (1H, m, arom H), 7.19-7.17 (1H, m, arom H), 7.16-6.98 (2H, m, arom H), 3.85, 3.84 (3H, s, OMe), 3.30-3.21 (1H, m, CH), 3.22, 3.21 (3H, s, N-Me), 2.12, 2.02 (3H, s, Ac), 1.23, 1.21 (3H, d, J = 6.0 Hz, Me) ppm. ¹³C NMR (75 MHz, CDCl₃): δ 205.1, 204.6 (C=O), 171.8, 171.2 (N-C=O), 154.9, 131.8, 129.9, 129.8, 129.5, 128.9, 121.3, 112.0, 11.9 (arom C), 55.4, 55.2 (CH),

51.6 (OMe), 36.4, 36.3 (N-Me), 27.9, 27.2 (Ac), 14.0, 13.6 (Me) ppm. HRMS (acetone/NBA) calcd for $C_{13}H_{18}NO_3$ 236.1287 (M+H). Found 236.1289.

***N*-Ethyl-2-methyl-3-oxo-*N*-phenylbutanamide (6j).**¹⁶⁰ Yield 95%. Yellow liquid. IR ($CHCl_3$): ν 1719 (C=O), 1647 (CONH) cm^{-1} . 1H NMR (300 MHz, $CDCl_3$): δ 7.49-7.37 (3H, m, arom H), 7.20-7.16 (2H, m, arom H), 3.78 (2H, q, $J = 6.0$ Hz, N- CH_2 -Me), 3.32 (1H, q, $J = 6.9$ Hz, CH), 2.02 (3H, s, Ac), 1.25 (3H, d, $J = 6.9$ Hz, Me), 1.15 (3H, t, $J = 6.0$ Hz, Me) ppm. ^{13}C NMR (75 MHz, $CDCl_3$): δ 204.9 (C=O), 170.1 (N-C=O), 141.9, 130.0, 128.6, 128.4 (arom C), 51.9 (CH), 44.4 (N- $\underline{C}H_2$), 27.9 (Ac), 13.8 (Me), 12.9 (Me) ppm. FAB HRMS (acetone/NBA) calcd for $C_{13}H_{18}NO_2$ 220.1338 (M+H). Found 220.1335.

***N*-Butyl-2-methyl-3-oxo-*N*-phenylbutanamide (6k).** Yield 67%. Orange liquid. IR ($CHCl_3$): ν 1718 (C=O), 1647 (CONH) cm^{-1} . 1H NMR (300 MHz, $CDCl_3$): δ 7.47-7.36 (3H, m, arom H), 7.19-7.15 (2H, m, arom H), 3.72 (2H, t, $J = 6.0$ Hz, N- CH_2), 3.32 (1H, q, $J = 6.0$ Hz, CH), 2.01 (3H, s, Ac), 1.51 (2H, quint, $J = 6.0$ Hz, CH_2), 1.33 (2H, sext, $J = 6.0$ Hz, CH_2), 1.25 (3H, d, $J = 6.0$ Hz, Me), 0.90 (3H, t, $J = 6.0$ Hz, Me) ppm. ^{13}C NMR (75 MHz, $CDCl_3$): δ 204.9 (C=O), 170.3 (N-C=O), 142.1, 130.0, 128.5, 128.4 (arom C), 51.9 (CH), 49.3 (N- $\underline{C}H_2$), 29.8 (CH_2), 28.0 (Me), 20.0 (CH_2), 13.9 (Me), 13.8 (Me) ppm. FAB HRMS (acetone/NBA) calcd for $C_{15}H_{22}NO_2$ 248.1651 (M+H). Found 248.1642.

***N*-Isopropyl-2-methyl-3-oxo-*N*-phenylbutanamide (6l).** Yield 90%. Yellow liquid. IR ($CHCl_3$): ν 1719 (C=O), 1643 (CONH) cm^{-1} . 1H NMR (300 MHz, $CDCl_3$): δ 7.45-7.743 (3H, m, arom H), 7.27-7.12 (2H, m, arom H), 5.01 (1H, q, $J = 6.9$ Hz, N-CH), 3.17 (1H, q, $J = 9.0$ Hz, CH), 1.99 (3H, s, Ac), 1.23 (3H, d, $J = 6.9$ Hz, Me), 1.12 (3H, d, $J = 7.2$ Hz, Me), 1.04 (3H, d, $J = 7.2$ Hz, Me) ppm. ^{13}C NMR (75 MHz, $CDCl_3$): δ 205.0 (C=O), 170.0 (N-C=O), 138.2, 130.5, 130.4, 129.5 (arom C), 52.5 (CH), 46.3 (N- $\underline{C}H$), 28.0 (Ac), 21.1, 20.8, 13.9 (Me) ppm. FAB HRMS (acetone/NBA) calcd for $C_{14}H_{20}NO_2$ 234.1494 (M+H). Found 234.1488.

2-Methyl-3-oxo-*N,N*-diphenylbutanamide (6m).²⁰ Yield quant. Colorless prisms (from EtOH), mp 73-74 °C. IR ($CHCl_3$): ν 1724 (C=O), 1664 (CONH) cm^{-1} . 1H NMR (500 MHz, $CDCl_3$): δ 7.44-7.19 (10H, m, arom H), 3.63 (1H, q, $J = 7.0$ Hz, CH), 2.07 (3H, s, Ac), 1.36 (3H, d, $J = 7.0$ Hz, Me) ppm. ^{13}C NMR (125 MHz, $CDCl_3$): δ 204.7 (C=O), 170.8 (>N-CO, 1C), 142.4, 130.1, 129.2, 128.9, 128.4, 126.3 (arom C), 52.4 (CH), 28.1 (Ac), 13.9 (Me) ppm.

2-Ethyl-*N*-methyl-3-oxo-*N*-phenylbutanamide (6n).¹⁹ Yield 48%. Yellow liquid. IR ($CHCl_3$): ν 1717 (C=O), 1651 (CONH) cm^{-1} . 1H NMR (300 MHz, $CDCl_3$): δ 7.48-7.36 (3H, m, arom H), 7.20-7.17 (2H, m, arom H), 3.32 (3H, s, N-Me), 3.27 (1H, t, $J = 6.0$ Hz, CH), 2.06 (3H, s, Ac), 1.99-1.72 (2H, m, $\underline{C}H_2$ -Me), 0.85 (3H, t, $J = 7.2$ Hz, Me) ppm. ^{13}C NMR (75 MHz, $CDCl_3$): δ 204.9 (C=O), 169.3 (N-C=O), 143.4, 130.0, 128.3, 127.7 (arom C), 59.2 (CH), 37.7 (N-Me), 28.1 (Ac), 23.0 (CH_2), 12.3 (Me) ppm.

***N*-Methyl-3-oxo-*N*-phenyl-2-propylbutanamide (6o).**¹⁹ Yield 47%. Brown liquid. IR ($CHCl_3$): ν 1716 (C=O), 1651 (CONH) cm^{-1} . 1H NMR (500 MHz, $CDCl_3$): δ 7.46-7.43 (2H, m, arom H), 7.39-7.37 (1H, m

arom H), 7.18-7.16 (2H, m, arom H), 3.36-3.33 (1H, m, CH), 3.31 (3H, s, N-Me), 2.02 (3H, s, Ac), 1.94-1.71 (1H, m, *H-CH*), 1.70-1.64 (1H, m, *HC-H*), 1.30-1.24 (1H, m, *H-CH*), 1.20-1.13 (1H, m, *HC-H*), 0.82 (3H, t, $J = 7.5$ Hz, Me) ppm. ^{13}C NMR (125 MHz, CDCl_3): δ 205.0 (C=O), 169.5 (N-C=O), 143.4, 130.0, 128.3, 127.7 (arom C), 57.6 (CH), 37.7 (N-Me), 31.7, 21.0 ($\underline{\text{CH}_2}$), 28.1 (Ac), 13.9 (Me) ppm.

2-Isopropyl-*N*-methyl-3-oxo-*N*-phenylbutanamide (6p). Yield 43%. Brown liquid. IR (CHCl_3): ν 1717 (C=O), 1651 (CONH) cm^{-1} . ^1H NMR (500 MHz, CDCl_3): δ 7.46-7.43 (2H, m, arom H), 7.39-7.36 (1H, m, arom H), 7.13-7.11 (2H, m, arom H), 3.30 (3H, s, N-Me), 3.05 (1H, d, $J = 10.5$ Hz, CH), 2.50 (1H, m, CH), 2.17 (3H, s, Ac), 0.92 (3H, d, $J = 7.0$ Hz, Me), 0.75 (3H, d, $J = 7.0$ Hz, Me) ppm. ^{13}C NMR (125 MHz, CDCl_3): δ 205.0 (C=O), 168.7 (N-C=O), 143.3, 129.9, 128.2, 127.9 (arom C), 66.1 (CH), 37.8 (N-Me), 30.3 (Ac), 27.6 (CH), 21.0, 20.1 (Me) ppm. FAB HRMS (acetone/NBA) calcd for $\text{C}_{14}\text{H}_{20}\text{NO}_2$ 234.1494 (M+H). Found 234.1499.

2-Butyl-*N*-methyl-3-oxo-*N*-phenylbutanamide (6q).¹⁹ Yield 33%. Orange liquid. IR (CHCl_3): ν 1720 (C=O), 1651 (CONH) cm^{-1} . ^1H NMR (500 MHz, CDCl_3): δ 7.46-7.43 (2H, m, arom H), 7.39-7.36 (1H, m, arom H), 7.18-7.16 (2H, m, arom H), 3.34-3.30 (1H, m, CH), 3.31 (3H, s, N-Me), 2.06 (3H, s, Ac), 1.93-1.87 (1H, m, *H-CH*), 1.73-1.68 (1H, m, *HC-H*), 1.26-1.18 (2H, m, CH_2), 1.14-1.08 (2H, m, CH_2), 0.85 (3H, t, $J = 7.0$ Hz, Me) ppm. ^{13}C NMR (125 MHz, CDCl_3): δ 205.0 (C=O), 169.5 (N-C=O), 143.4, 130.0, 128.3, 127.8 (arom C), 57.8 (CH), 37.7 (N-Me), 28.0 (Ac), 29.8, 29.3, 22.4 (CH_2), 13.7 (Me) ppm.

***N*,2-Dimethyl-*N*-(1-naphthyl)-3-oxobutanamide (6r).** Rotamer ratio = 1.2:1. Yield 77%. Colorless microcrystals (from EtOH), mp 79 °C. IR (CHCl_3): ν 1719 (C=O), 1651 (CONH) cm^{-1} . ^1H NMR (300 MHz, CDCl_3): δ 7.92-7.31 (7H, m, arom H), 3.42 (3H, s, NMe), 3.18-3.13 (1H, m, CH), 1.97, 1.95 (3H, s, Ac), 1.26, 1.19 (3H, d, $J = 6.9$ Hz, Me) ppm. ^{13}C NMR (75 MHz, CDCl_3): δ 205.1, 203.8 (C=O), 171.9, 171.0 (N-C=O), 139.4, 139.2, 134.7, 134.6, 129.9, 129.8, 129.2, 129.0, 128.8, 128.7, 127.7, 127.6, 127.0, 126.9, 126.0, 125.8, 125.7, 125.5, 122.2, 121.8 (arom C), 51.7, 51.4 (CH), 37.2 (N-Me), 28.0, 27.8 (Ac), 14.2, 14.1 (Me) ppm. MS (rel intensity): m/z 255 (45), 157 (100), 128 (40), 112 (80), 70 (45). Anal. Calcd for $\text{C}_{16}\text{H}_{17}\text{NO}_2$: C, 75.27; H, 6.71; N, 5.49. Found: C, 75.28; H, 6.92; N, 5.52.

***N*,2-Dimethyl-*N*-(2-naphthyl)-3-oxobutanamide (6s).** Yield 79%. Colorless microcrystals (from EtOH), mp 103 °C. IR (CHCl_3): ν 1726 (C=O), 1654 (CONH) cm^{-1} . ^1H NMR (300 MHz, CDCl_3): δ 7.96-7.85 (3H, m, arom H), 7.71 (1H, m, arom H), 7.56-7.53 (2H, m, arom H), 7.35-7.31 (1H, m, arom H), 3.49 (1H, q, $J = 6.9$ Hz, CH), 3.39 (3H, s, NMe), 2.00 (3H, s, Ac), 1.28 (3H, d, $J = 6.9$ Hz, Me) ppm. ^{13}C NMR (75 MHz, CDCl_3): δ 204.1 (C=O), 170.3 (N-C=O), 140.3, 133.1, 132.0, 129.9, 127.4, 127.3, 126.7, 126.6, 125.6, 124.6 (arom C), 51.3 (CH), 37.1 (N-Me), 27.6 (Ac), 13.3 (Me) ppm. MS m/z (rel intensity): 255 (55, M^+), 157 (100), 127 (35), 112 (30). Anal. Calcd for $\text{C}_{16}\text{H}_{17}\text{NO}_2$: C, 75.27; H, 6.71; N, 5.49. Found: C, 75.11; H, 6.91; N, 5.47.

Oxidation of 3-Oxo-*N*-phenylbutanamides 1a-c in Acetic Acid. To a 3-oxo-*N*-phenylbutanamide **1** (0.5 mmol) dissolved in glacial AcOH (15 mL) was added Mn(OAc)₃•2H₂O (1 or 2 mmol), and the mixture was degassed under reduced pressure for 30 min using an ultrasonicator for exchange with an argon atmosphere. The mixture was heated under reflux in an argon atmosphere until the brown color of Mn(III) disappeared (normally 1 or 2 min). The mixture was concentrated under reduced pressure and 2M HCl (20 mL) was added. The aqueous solution was then extracted three times with CHCl₃ (20 mL x 3). The combined extracts were washed with a saturated aqueous solution of NaHCO₃ and water, dried over anhydrous MgSO₄, and then concentrated to dryness, giving an intractable mixture and no isolated products were obtained except for a small amount of unchanged **1**.

Mn(III)-Based Oxidation of 3-Oxo-*N*-phenylbutanamide 1a (R = H) in the Presence of Alkene as a Radical Trapping Reagent.²¹ To a mixture of 3-oxobutanamide **1a** (0.177 g; 1 mmol) and 1,1-diphenylethene (0.180 g; 1 mmol) in glacial AcOH (15 mL) was added Mn(OAc)₃•2H₂O (0.992 g; 4 mmol), then the mixture was heated under reflux until the brown color of Mn(III) disappeared (for 1 min). After the work-up described above, 2-methyl-*N*,5,5-triphenyl-4,5-dihydrofuran-3-carboxamide (**VI**) was obtained in 0.155 g (43% yield) as a colorless solid which was recrystallized using CHCl₃–hexane.

2-Methyl-*N*,5,5-triphenyl-4,5-dihydrofuran-3-carboxamide (VI). Colorless needles (from CHCl₃–hexane), mp 248-251 °C. IR (CHCl₃): ν 3400-3200 (NH), 1662 (C=O), 1632 (C=C) cm⁻¹. ¹H NMR (500 MHz, CDCl₃): δ 7.50-7.48 (2H, m, arom H), 7.42-7.40 (4H, m, arom H), 7.38-7.34 (4H, m, arom H), 7.31-7.26 (4H, m, arom H), 7.09-7.06 (1H, m, arom H), 6.84 (1H, s, NH), 3.68 (1H, s, CH₂), 2.45 (3H, s, Me) ppm. ¹³C NMR (125 MHz, CDCl₃): δ 163.6 (C=O), 152.6 (C-2), 144.9, 138.0 (arom C), 128.9, 128.5, 127.7, 125.7, 124.0, 120.0 (arom CH), 102.7 (C-3), 90.9 (C-5), 44.7 (C-4), 14.3 (Me) ppm. MS *m/z* (rel intensity): 355 (33, M⁺), 313 (40), 262 (100), 247 (70), 221 (45), 191 (90), 175 (40), 165 (75), 115 (70), 105 (3), 93 (60), 77 (70). Anal. Calcd for C₂₄H₂₁NO₂•1/10H₂O: C, 80.70; H, 5.93; N, 3.92. Found: C, 80.58; H, 5.96; N, 3.97.

Oxidation of *N*-Methyl-3-oxo-*N*-phenylbutanamide (1b) in Ethanol. A mixture of butanamide **1b** (3 mmol) and Mn(OAc)₃•2H₂O (12 mmol) in EtOH (60 mL) was degassed under reduced pressure for 20 min using an ultrasonicator for exchange with an argon atmosphere and then heated under reflux until the brown color of Mn(III) disappeared (for 4 min). 2M HCl (25 mL) was added to the reaction mixture and the aqueous solution was extracted three times with CH₂Cl₂ (25 mL x 3). The combined extracts were washed with a saturated aqueous solution of NaHCO₃, dried over anhydrous MgSO₄, and then concentrated to dryness. The residue was separated on silica gel TLC (Wako B-10) while eluting with Et₂O, affording the dimeric 3,3'-biindoline-2,2'-dione derivatives **3**, **4**, and **5**. The analytical samples were further purified by recrystallization from the solvent specified in parentheses and their physical data are listed below.

3,3'-Diacetyl-1,1'-dimethyl-[3,3'-biindoline]-2,2'-dione (3). Yield 9%. Colorless microcrystals (from EtOH), mp 176-177 °C. IR (KBr): ν 1728 (C=O), 1686 (CONH) cm^{-1} . ^1H NMR (300 MHz, CDCl_3): δ 7.31-7.26 (4H, m, arom H), 7.00-6.95 (2H, m, arom H), 6.75-6.72 (2H, m, arom H), 3.19 (6H, s, N-Me), 2.10 (6H, s, Ac) ppm. ^{13}C NMR (75 MHz, CDCl_3): δ 199.3 (C=O), 171.9 (N-C=O), 144.4, 129.8, 127.2, 123.7, 122.4, 108.2 (arom C), 69.3 (>C<), 28.5 (N-Me), 26.7 (Ac) ppm. FAB HRMS (acetone/NBA) calcd for $\text{C}_{22}\text{H}_{21}\text{N}_2\text{O}_4$ 377.1501 (M+H). Found 377.1517.

1,1'-Dimethyl-[3,3'-biindoline]-2,2'-dione (4). A 1:1 diastereomer mixture. Yield 7%. Colorless microcrystals (from EtOH), mp 197-198 °C (lit,²² mp 194-196 °C). IR (KBr): ν 1720 (CONH) cm^{-1} . ^1H NMR (300 MHz, CDCl_3): δ 7.29-7.27 (1H, m, arom H), 7.11-7.08 (1H, m, arom H), 6.95-6.90 (2H, m, arom H), 6.82-6.75 (3H, m, arom H), 6.70-6.67 (1H, m, arom H), 4.29 (1H, s, CH), 4.18 (1H, s, CH'), 3.28 (3H, s, N-Me), 3.12 (3H, s, N-Me') ppm. ^{13}C NMR (75 MHz, CDCl_3): δ 175.9, 174.7 (N-C=O), 145.0, 144.2, 128.8, 128.4, 125.8, 124.8, 123.3, 123.2, 122.5, 122.4, 108.3, 108.0 (arom C), 46.2, 46.1 (CH), 26.3, 26.2 (N-Me) ppm. MS m/z (rel intensity): 292 (20, M^+), 146 (100), 118 (18), 91 (35), 77 (12), 65 (12), 51 (13).

(E)-1,1'-Dimethyl-[3,3'-biindolinylidene]-2,2'-dione (5).²³ Yield 32%. Reddish prisms (from EtOH), mp 275-276 °C (lit, mp 278 °C, ^{23a} 274-275 °C^{23d}). IR (KBr): ν 1680 (CONH) cm^{-1} . ^1H NMR (300 MHz, CDCl_3): δ 9.20 (2H, d, $J = 7.8$ Hz, H-4 and H-4'), 7.4 (2H, t, $J = 7.5$ Hz, H-6 and H-6'), 7.07 (2H, t, $J = 7.5$ Hz, H-5 and H-5'), 6.79 (2H, d, $J = 7.8$ Hz, H-7 and H-7'), 3.29 (6H, s, N-Me) ppm. ^{13}C NMR (75 MHz, CDCl_3): δ 168.0 (N-C=O), 145.2, 132.4, 129.8, 122.4, 121.6, 107.7 (arom C), 26.1 (N-Me) ppm. MS m/z (rel intensity): 290 (100, M^+), 262 (45), 233 (50), 218 (30), 146 (20), 117 (25).

Oxidation of *N*,2-Disubstituted *N*-Aryl-3-oxobutanamides 6a-s in Acetic Acid. The general procedure for the reaction of 3-oxobutanamides **6a-s** with $\text{Mn}(\text{OAc})_3 \cdot 2\text{H}_2\text{O}$ was as follows. To 3-oxobutanamide **6** (0.5 mmol) dissolved in glacial AcOH (15 mL) was added $\text{Mn}(\text{OAc})_3 \cdot 2\text{H}_2\text{O}$ (1 mmol). The mixture was quickly heated under reflux using a pre-heated oil bath at 140 °C until the brown color of Mn(III) disappeared (normally within 3-5 min). The solvent was removed under reduced pressure and the residue was triturated with 2M HCl (15 mL). The aqueous mixture was extracted three times with CHCl_3 (20 mL x 3), and the combined extracts were washed with a saturated aqueous solution of NaHCO_3 and water, dried over anhydrous MgSO_4 , and then concentrated to dryness, giving the desired acetylidolinone **7**. If needed, the obtained acetylidolinone **7** was purified by silica gel TLC eluting with Et_2O -hexane (7:3 v/v) and the solid **7** was recrystallized from the appropriate solvent as mentioned below. When the separation of the product **7** was performed using neutral Al_2O_3 eluting with Et_2O -hexane (7:3 v/v), deacetylated indolinone **8** was obtained (vide infra).

3-Acetyl-1,3-dimethylindolin-2-one (7a).^{16g,24} Yield quant. IR (CHCl_3): ν 1720, 1709 (C=O) cm^{-1} . ^1H NMR (300 MHz, CDCl_3): δ 7.35 (1H, t, $J = 7.2$ Hz, arom H), 7.16 (1H, d, $J = 7.2$ Hz, arom H), 7.09 (1H,

t, $J = 7.2$ Hz, arom H), 6.92 (1H, d, $J = 7.2$ Hz, arom H), 3.30 (3H, s, Me), 1.97 (3H, s, Ac), 1.58 (3H, s, Me) ppm. ^{13}C NMR (75 MHz, CDCl_3): δ 201.0, 175.9 (C=O), 143.7, 129.4 (arom C), 129.2, 123.5, 123.3, 108.6 (arom CH), 62.0 (C-3), 26.6 (Me), 25.9 (Me), 18.9 (Me) ppm.

3-Acetyl-5-fluoro-1,3-dimethylindolin-2-one (7b). Yield 99%. Yellow liquid. IR (CHCl_3): ν 1728, 1707 (C=O) cm^{-1} . ^1H NMR (500 MHz, CDCl_3): δ 6.98 (1H, dt, $J = 8.5, 2.5$ Hz, arom H), 6.86 (1H, dd, $J = 8.5, 2.5$ Hz, arom H), 6.77 (1H, dd, $J = 8.5, 4.0$ Hz, arom H), 3.22 (3H, s, Me), 1.94 (3H, s, Me), 1.51 (3H, s, Me). ^{13}C NMR (125MHz, CDCl_3): δ 200.5, 175.4 (C=O), 159.4 (d, $^1J = 242.2$ Hz), 139.5, 130.8 (d, $^3J = 8.3$ Hz) (arom C), 115.4 (d, $^2J = 22.8$ Hz), 111.9 (d, $^2J = 25.2$ Hz), 109.0 (d, $^3J = 8.4$ Hz) (arom CH), 62.2 (C-3), 26.7, 25.9, 19.2 (Me). FAB HRMS (acetone/NBA) calcd for $\text{C}_{12}\text{H}_{13}\text{FNO}_2$ 222.0930 (M+H). Found 222.0929.

3-Acetyl-5-chloro-1,3-dimethylindolin-2-one (7c). Yield quant. Colorless microcrystals (from hexane), mp 80-83 °C. IR (CHCl_3): ν 1728, 1713 (C=O) cm^{-1} . ^1H NMR (300 MHz, CDCl_3): δ 7.33 (1H, dd, $J = 8.1, 1.8$, Hz, H-6), 7.16 (1H, d, $J = 1.8$ Hz, H-4), 6.84 (1H, d, $J = 8.1$ Hz, H-7), 3.23 (3H, s, Me), 2.02 (3H, s, Me), 1.58 (3H, s, Me). ^{13}C NMR (75MHz, CDCl_3): δ 200.3, 175.4 (C=O), 142.2, 130.9, 129.1 (arom C), 128.6, 124.2, 109.5 (arom CH), 62.0 (C-3), 26.8, 26.0, 19.3 (Me). Anal. Calcd for $\text{C}_{12}\text{H}_{12}\text{ClNO}_2$: C, 60.49; H, 5.09; N, 5.89. Found: C, 60.41; H, 5.04; N, 5.96.

3-Acetyl-7-chloro-1,3-dimethylindolin-2-one (7d). Yield quant. Orange liquid. IR (CHCl_3): ν 1717 (C=O) cm^{-1} . ^1H NMR (300 MHz, CDCl_3): δ 7.29-7.26 (1H, m, arom H), 7.05-6.97 (2H, m, arom H), 3.66 (3H, s, Me), 1.99 (3H, s, Me), 1.57 (3H, s, Me). ^{13}C NMR (75MHz, CDCl_3): δ 200.3, 176.1 (C=O), 131.9 (arom C), 131.4, 124.0 (2C), 122.1 (arom CH), 115.9 (arom C), 61.7 (C-3), 30.0, 26.0, 19.5 (Me). FAB HRMS (acetone/NBA/NaI) calcd for $\text{C}_{12}\text{H}_{12}\text{ClNO}_2\text{Na}$ 260.0454 (M+Na). Found 260.0454.

3-Acetyl-1,3,5-trimethylindolin-2-one (7e). Yield quant. Colorless prisms (from EtOH), mp 92-95 °C (lit, ^{16j,24} mp 90-93 °C). IR (CHCl_3): ν 1724, 1701 (C=O) cm^{-1} . ^1H NMR (300 MHz, CDCl_3): δ 7.16 (1H, dd, $J = 7.5, 0.6$, Hz, H-6), 6.94 (1H, d, $J = 0.6$ Hz, H-4), 6.80 (1H, d, $J = 7.5$ Hz, H-7), 3.28 (3H, s, Me), 2.33 (3H, s, Me), 1.94 (3H, s, Me), 1.58 (3H, s, Me). ^{13}C NMR (75MHz, CDCl_3): δ 201.2, 175.9 (C=O), 141.3, 132.3 (2C) (arom C), 129.4, 124.3, 108.6 (arom CH), 62.1 (C-3), 26.7, 25.9, 21.1, 18.9 (Me). Anal. Calcd for $\text{C}_{13}\text{H}_{15}\text{NO}_2$: C, 71.87; H, 6.96; N, 6.45. Found: C, 71.74; H, 7.04; N, 6.55.

3-Acetyl-1,3,7-trimethylindolin-2-one (7f).²⁴ Yield 94%. Colorless microcrystals (from EtOH), mp 80-83 °C (lit, ^{16j} mp 79-81 °C). IR (CHCl_3): ν 1724, 1701 (C=O) cm^{-1} . ^1H NMR (300 MHz, CDCl_3): δ 7.09-7.06 (1H, m, arom H), 6.97-6.95 (2H, m, arom H), 3.58 (3H, s, Me), 2.62 (3H, s, Me), 1.95 (3H, s, Me), 1.54 (3H, s, Me). ^{13}C NMR (75MHz, CDCl_3): δ 201.1, 176.6 (C=O), 141.5, 130.0, 120.2 (arom C), 132.8, 123.1, 121.4 (arom CH), 61.5 (C-3), 29.9, 25.8, 19.3, 19.0 (Me). Anal. Calcd for $\text{C}_{13}\text{H}_{15}\text{NO}_2$: C, 71.87; H, 6.96; N, 6.45. Found: C, 71.73; H, 7.07; N, 6.37.

3-Acetyl-5-methoxy-1,3-dimethylindolin-2-one (7g). Yield 89%. Colorless microcrystals (from hexane), mp 89-92 °C. IR (CHCl₃): ν 1724, 1701 (C=O) cm⁻¹. ¹H NMR (300 MHz, CDCl₃): δ 6.88 (1H, dd, J = 8.4, 2.1, Hz, H-6), 6.826 (1H, d, J = 8.4 Hz, H-7), 6.764 (1H, d, J = 2.1 Hz, H-4), 3.80 (3H, s, MeO), 3.22 (3H, s, Me), 1.97 (3H, s, Me), 1.57 (3H, s, Me). ¹³C NMR (75MHz, CDCl₃): δ 201.1, 175.6 (C=O), 156.5, 137.1, 130.6 (arom C), 113.7, 110.6, 109.0 (arom CH), 62.4 (C-3), 55.9 (MeO), 26.7, 25.9, 19.0 (Me). Anal. Calcd for C₁₃H₁₅NO₃: C, 66.94; H, 6.48; N, 6.00. Found: C, 66.80; H, 6.59; N, 6.00.

A Mixture of 3-Acetyl-6-methoxy-1,3-dimethylindolin-2-one and 3-Acetyl-4-methoxy-1,3-dimethylindolin-2-one (7h). 6-Mthoxy-7h:4-methoxy-7h = 1.8:1. Yield 83%. Colorless microcrystals (from hexane), mp 100-103 °C. IR (CHCl₃): ν 1730, 1701 (C=O) cm⁻¹. ¹H NMR (500 MHz, CDCl₃): δ 7.35-7.30 (m, arom H), 7.04 (d, J = 8.0 Hz, arom H), 6.67 (d, J = 8.0 Hz, arom H), 6.61-6.58 (m, arom H), 6.52 (d, J = 1.5 H, arom H), 3.85, 3.82 (s, MeO), 3.28, 3.27 (s, Me), 1.95, 1.92 (s, Me), 1.61, 1.54 (s, Me). ¹³C NMR (75MHz, CDCl₃): δ 201.1, 200.3, 176.3, 174.9 (C=O), 160.9, 155.6, 145.0, 144.9, 121.1, 116.2 (arom C), 130.3, 124.0, 106.9, 106.1, 101.7, 96.6 (arom CH), 61.5, 61.3 (C-3), 55.5, 55.4 (MeO), 26.8, 26.5, 25.6, 25.5, 18.8, 16.7 (Me). Anal. Calcd for C₁₃H₁₅NO₃: C, 66.94; H, 6.48; N, 6.00. Found: C, 66.77; H, 6.54; N, 5.97.

3-Acetyl-7-methoxy-1,3-dimethylindolin-2-one (7i). Yield 89%. Brown liquid. IR (CHCl₃): ν 1724, 1701 (C=O) cm⁻¹. ¹H NMR (300 MHz, CDCl₃): δ 7.03 (1H, t, J = 8.1 Hz, H-5), 6.91 (1H, br. d, J = 8.1 Hz, H-6), 6.75 (1H, br. d, J = 7.8 Hz, H-4), 3.89 (3H, s, MeO), 3.56 (3H, s, Me), 1.95 (3H, s, Me), 1.54 (3H, s, Me). ¹³C NMR (75MHz, CDCl₃): δ 201.0, 176.0 (C=O), 145.5, 131.5, 130.9, (arom C), 123.7, 116.0, 112.8 (arom CH), 62.2 (C-3), 56.0 (MeO), 29.9, 25.8, 19.0 (Me). FAB HRMS (acetone/NBA/NaI) calcd for C₁₃H₁₅NO₃Na 256.0950 (M+Na). Found 256.0959.

3-Acetyl-1-ethyl-3-methylindolin-2-one (7j). Yield 96%. Orange liquid. IR (CHCl₃): ν 1724, 1705 (C=O) cm⁻¹. ¹H NMR (300 MHz, CDCl₃): δ 7.34 (1H, dd, J = 7.8, 1.2 Hz, arom H), 7.15 (1H, m, arom H), 7.08 (1H, br. t, J = 7.5 Hz, arom H), 6.94 (1H, br. d, J = 7.8 Hz, arom H), 3.96-3.73 (2H, m, -CH₂-CH₃), 1.95 (3H, s, Me), 1.57 (3H, s, Me), 1.32 (3H, t, J = 7.2 Hz, -CH₂-CH₃). ¹³C NMR (75MHz, CDCl₃): δ 201.0, 175.5 (C=O), 142.8, 129.7 (arom C), 129.1, 123.7, 123.0, 108.7 (arom CH), 62.0 (C-3), 35.0 (N-CH₂), 25.8, 18.7 (Me), 12.5 (N-CH₂-CH₃). FAB HRMS (acetone/NBA/NaI) calcd for C₁₃H₁₅NO₂Na 240.1000 (M+Na). Found 240.1004.

3-Acetyl-1-butyl-3-methylindolin-2-one (7k). Yield 98%. Orange liquid. IR (CHCl₃): ν 1724, 1705 (C=O) cm⁻¹. ¹H NMR (300 MHz, CDCl₃): δ 7.36-7.30 (1H, m, arom H), 7.16-7.14 (1H, m, arom H), 7.10-7.05 (1H, m, arom H), 6.92 (1H, br. d, J = 6.6 Hz, arom H), 3.87-3.69 (2H, m, N-CH₂-CH₂CH₂CH₃), 1.96 (3H, s, Me), 1.71 (2H, quint, J = 7.2 Hz, N-CH₂-CH₂-CH₂CH₃), 1.56 (3H, s, Me), 1.43 (2H, sex, J = 7.2 Hz, N-CH₂CH₂-CH₂-CH₃), 0.98 (3H, t, J = 7.2 Hz, N-CH₂CH₂CH₂-CH₃). ¹³C NMR (75MHz, CDCl₃): δ 201.1, 175.8 (C=O), 143.2, 129.6 (arom C), 129.1, 123.7, 123.0, 108.9 (arom CH), 61.9 (C-3), 40.1

(N-CH₂-CH₂CH₂CH₃), 29.4 (CH₂), 25.9 (Me), 20.2 (CH₂), 18.9 (Me), 13.7 (Me). FAB HRMS (acetone/NBA/NaI) calcd for C₁₅H₁₉NO₂Na 268.1313 (M+Na). Found 268.1312.

3-Acetyl-1-isopropyl-3-methylindolin-2-one (7l). Yield 93%. Orange liquid. IR (CHCl₃): ν 1724, 1701 (C=O) cm⁻¹. ¹H NMR (500 MHz, CDCl₃): δ 7.31 (1H, br. t, J = 8.0 Hz, arom H), 7.13 (1H, br. d, J = 7.0 Hz, arom H), 7.07 (2H, br. t, J = 7.5 Hz, arom H), 4.68 (1H, sep, J = 7.0 Hz, N-CHMe₂), 1.93 (3H, s, Me), 1.55 (3H, s, Me), 1.54 (3H, d, J = 7.0 Hz, Me), 1.53 (3H, d, J = 7.0 Hz, Me). ¹³C NMR (75MHz, CDCl₃): δ 200.9, 175.6 (C=O), 142.5, 129.8 (arom C), 128.8, 123.7, 122.7, 110.2 (arom CH), 61.9 (C-3), 44.2 (CH), 25.6 (Me), 19.3 (Me), 19.2 (Me), 18.7 (Me). FAB HRMS (acetone/NBA/NaI) calcd for C₁₄H₁₇NO₂Na 254.1157 (M+Na). Found 254.1158.

3-Acetyl-3-methyl-1-phenylindolin-2-one (7m). Yield 91%. Colorless needles (from EtOH), mp 112-115 °C (lit,^{24d} mp 101-103 °C). IR (CHCl₃): ν 1728, 1710 (C=O) cm⁻¹. ¹H NMR (500 MHz, CDCl₃): δ 7.56 (2H, d, J = 7.5 Hz, arom H), 7.46-7.44 (3H, m, arom H), 7.28 (1H, t, J = 7.5 Hz, arom H), 7.22 (1H, d, J = 6.5 Hz, arom H), 7.13 (1H, t, J = 8.0 Hz, arom H), 6.90 (1H, d, J = 8.0 Hz, arom H), 2.11 (3H, s, Me), 1.70 (3H, s, Me). ¹³C NMR (125MHz, CDCl₃): δ 200.7, 175.3 (C=O), 143.7, 134.1, 129.2 (arom C), 129.8, 129.1, 128.4, 126.4, 123.8, 123.7, 109.9 (arom CH), 62.1 (C-3), 26.0 (Me), 19.2 (Me). Anal. Calcd for C₁₇H₁₅NO₂: C, 76.96; H, 5.70; N, 5.28. Found: C, 76.99; H, 5.68; N, 5.30.

3-Acetyl-3-ethyl-1-methylindolin-2-one (7n).^{16g} Yield 98%. Orange liquid. IR (CHCl₃): ν 1719, 1705 (C=O) cm⁻¹. ¹H NMR (300 MHz, CDCl₃): δ 7.30-7.25 (1H, m, arom H), 7.10 (1H, d, J = 7.5 Hz, arom H), 7.03 (1H, t, J = 7.5 Hz, arom H), 6.83 (1H, d, J = 8.0 Hz, arom H), 3.22 (3H, s, Me), 2.21-2.07 (2H, m, CH₂-CH₃), 1.94 (3H, s, Me), 0.53 (3H, t, J = 7.5 Hz, CH₂-CH₃). ¹³C NMR (75MHz, CDCl₃): δ 201.4, 175.0 (C=O), 144.3, 127.2 (arom C), 129.0, 123.9, 123.1, 108.3 (arom CH), 67.3 (C-3), 26.6 (Me x 2), 26.4 (CH₂), 8.1 (Me). FAB HRMS (acetone/NBA/NaI) calcd for C₁₃H₁₅NO₂Na 240.1000 (M+Na). Found 240.1000.

3-Acetyl-1-methy-3-propylindolin-2-one (7o). Yield 94%. Orange liquid. IR (CHCl₃): ν 1722, 1705 (C=O) cm⁻¹. ¹H NMR (500 MHz, CDCl₃): δ 7.35 (1H, t, J = 7.5 Hz, arom H), 7.17 (1H, d, J = 7.5 Hz, arom H), 7.10 (1H, t, J = 7.5 Hz, arom H), 6.90 (1H, d, J = 7.5 Hz, arom H), 3.29 (3H, s, Me), 2.20-2.08 (2H, m, CH₂-CH₂CH₃), 2.00 (3H, s, Me), 1.05-0.97 (2H, m, CH₂-CH₂-CH₃), 0.82 (3H, t, J = 6.0 Hz, CH₂CH₂-CH₃). ¹³C NMR (125MHz, CDCl₃): δ 201.3, 175.2 (C=O), 144.2, 127.6 (arom C), 129.0, 123.9, 123.1, 108.4 (arom CH), 66.8 (C-3), 35.5 (CH₂), 26.5 (Me), 26.4 (Me), 17.2 (CH₂), 14.1 (Me). FAB HRMS (acetone/NBA/NaI) calcd for C₁₄H₁₇NO₂Na 254.1157 (M+Na). Found 254.1157.

3-Acetyl-3-isopropyl-1-methylindolin-2-one (7p). Yield 4%. Orange liquid. IR (CHCl₃): ν 1722, 1707 (C=O) cm⁻¹. ¹H NMR (500 MHz, CDCl₃): δ 7.34 (1H, dt, J = 7.5, 1.0 Hz, arom H), 7.28 (1H, d, J = 7.5 Hz, arom H), 7.10 (1H, t, J = 7.5 Hz, arom H), 6.87 (1H, d, J = 7.5 Hz, arom H), 3.26 (3H, s, Me), 2.84 (1H, sep, J = 7.0 Hz, CHMe₂), 2.17 (3H, s, Me), 0.89 (3H, d, J = 7.0 Hz, Me), 0.84 (3H, d, J = 7.0 Hz,

Me). ^{13}C NMR (125MHz, CDCl_3): δ 202.3, 174.3 (C=O), 144.0, 129.5, (arom C), 128.7, 125.2, 122.8, 108.0 (arom CH), 70.4 (C-3), 34.5 (CH), 27.7 (Me), 26.3 (Me), 17.5 (Me), 17.1 (Me). FAB HRMS (acetone/NBA/NaI) calcd for $\text{C}_{14}\text{H}_{18}\text{NO}_2$ 232.1338 (M+H). Found 232.1335.

3-Acetyl-3-butyl-1-methylindolin-2-one (7q). Yield 81%. Colorless liquid. IR (CHCl_3): ν 1722, 1705 (C=O) cm^{-1} . ^1H NMR (500 MHz, CDCl_3): δ 7.35 (1H, t, $J = 7.5$ Hz, arom H), 7.17 (1H, d, $J = 7.5$ Hz, arom H), 7.104 (1H, t, $J = 7.5$ Hz, arom H), 6.91 (1H, d, $J = 7.5$ Hz, arom H), 3.30 (3H, s, Me), 2.22-2.11 (2H, m, $\text{CH}_2\text{-CH}_2\text{CH}_2\text{CH}_3$), 2.00 (3H, s, Me), 1.29-1.17 (2H, m, $\text{CH}_2 \times 2$), 1.00-0.91 (1H, m, CHH), 0.78 (3H, t, $J = 7.5$ Hz, N- $\text{CH}_2\text{CH}_2\text{CH}_2\text{-CH}_3$), 0.75-0.72 (1H, m, CHH). ^{13}C NMR (125MHz, CDCl_3): δ 201.4, 175.2 (C=O), 144.2, 127.6 (arom C), 129.0, 123.9, 123.2, 108.4 (arom CH), 66.7 (C-3), 33.1 (N- $\text{CH}_2\text{-CH}_2\text{CH}_2\text{CH}_3$), 26.5 (Me), 26.4 (Me), 25.8 (CH_2), 22.7 (CH_2), 13.8 (Me). FAB HRMS (acetone/NBA/NaI) calcd for $\text{C}_{15}\text{H}_{19}\text{NO}_2\text{Na}$ 268.1313 (M+Na). Found 268.1316.

3-Acetoxy-3-butyl-1-methylindolin-2-one (9). Yield 60%. Colorless liquid. IR (CHCl_3): ν 1728 (C=O), 1244 (C-O-C) cm^{-1} . ^1H NMR (500 MHz, CDCl_3): δ 7.32 (1H, t, $J = 7.5$ Hz, arom H), 7.21 (1H, d, $J = 7.5$ Hz, arom H), 7.05 (1H, t, $J = 7.5$ Hz, arom H), 6.84 (1H, d, $J = 7.5$ Hz, arom H), 3.29 (3H, s, Me), 2.04 (3H, s, Me), 2.00-1.90 (2H, m, N- $\text{CH}_2\text{-CH}_2\text{CH}_2\text{CH}_3$), 1.29-1.17 (3H, m, CHH- CH_2CH_3), 1.14-1.08 (1H, m, CHH- CH_2CH_3), 0.83 (3H, t, $J = 7.5$ Hz, N- $\text{CH}_2\text{CH}_2\text{CH}_2\text{-CH}_3$). ^{13}C NMR (125MHz, CDCl_3): δ 175.2, 169.0 (C=O), 144.0, 127.9 (arom C), 129.6, 122.6, 122.5, 108.3 (arom CH), 80.1 (C-3), 36.4 (N- $\text{CH}_2\text{-CH}_2\text{CH}_2\text{CH}_3$), 26.4 (Me), 24.1 (CH_2), 22.7 (CH_2), 20.7 (Me), 13.8 (Me). FAB HRMS (acetone/NBA/NaI) calcd for $\text{C}_{15}\text{H}_{19}\text{NO}_3\text{Na}$ 284.1263 (M+Na). Found 284.1254.

3-Acetyl-1,3-dimethyl-1H-benzo[g]indol-2(3H)-one (7r). Yield 96%. Colorless microcrystals (from EtOH), mp 128 °C. IR (CHCl_3): ν 1724, 1647 (C=O) cm^{-1} . ^1H NMR (300 MHz, CDCl_3): δ 7.79 (1H, d, $J = 8.0$ Hz, arom H), 7.58 (1H, d, $J = 8.0$ Hz, arom H), 7.50 (2H, t, $J = 7.5$ Hz, arom H), 7.15 (1H, d, $J = 8.0$ Hz, arom H), 7.07 (1H, d, $J = 8.0$ Hz, arom H), 3.60 (3H, s, Me), 2.05 (3H, s, Me), 1.78 (3H, s, Me). ^{13}C NMR (75MHz, CDCl_3): δ 201.3, 169.5 (C=O), 136.4, 133.7, 133.0, 118.8 (arom C), 127.2, 127.1, 126.8, 123.5, 123.0, 109.2 (arom CH), 60.9 (C-3), 29.6 (Me), 27.1 (Me), 26.9 (Me). Anal. Calcd for $\text{C}_{16}\text{H}_{15}\text{NO}_2$: C, 75.87; H, 5.97; N, 5.53. Found: C, 75.83; H, 6.11; N, 5.60.

1-Acetyl-1,3-dimethyl-1H-benzo[e]indol-2(3H)-one (7s). Yield 99%. Colorless microcrystals (from EtOH), mp 132 °C. IR (CHCl_3): ν 1726, 1694 (C=O) cm^{-1} . ^1H NMR (300 MHz, CDCl_3): δ 7.83 (1H, d, $J = 8.4$ Hz, arom H), 7.75 (1H, d, $J = 8.1$ Hz, arom H), 7.48 (1H, d, $J = 8.1$ Hz, arom H), 7.35 (1H, t, $J = 8.1$ Hz, arom H), 7.24 (1H, t, $J = 8.1$ Hz, arom H), 7.17 (1H, d, $J = 8.4$ Hz, arom H), 3.30 (3H, s, Me), 1.74 (3H, s, Me), 1.66 (3H, s, Me). ^{13}C NMR (75MHz, CDCl_3): δ 201.0, 176.0 (C=O), 141.6, 130.4 (2C), 128.9 (arom C), 130.3, 129.3, 127.8, 124.0, 121.3, 109.5 (arom CH), 63.0 (C-3), 26.7 (Me), 25.7 (Me), 18.4 (Me). Anal. Calcd for $\text{C}_{16}\text{H}_{15}\text{NO}_2$: C, 75.87; H, 5.97; N, 5.53. Found: C, 75.98; H, 6.14; N, 5.77.

Deacetylation of 3-Actyl-1,3-dimethylindolin-2-ones 7. To the obtained dimethylindolinone **7** (0.5 mmol) in Et₂O (30 mL) was added neutral Al₂O₃ (7 g) in a 100-mL round-bottomed flask, and stirred at room temperature for 1 h. The reaction mixture was filtered using a 3G2 glass filter, washed with CHCl₃, and concentrated. The residue was again dissolved in CHCl₃, washed with a saturated aqueous solution of NaHCO₃, water, dried over anhydrous MgSO₄, and then concentrated to dryness. The crude deacetylated indolinone **8** was separated by silica gel TLC eluting with hexane. The solid product **8** was recrystallized from the appropriate solvent as mentioned below.

1,3-Dimethylindolin-2-one (8a). ^{16a,16d,16n,25} Yield quant. Colorless prisms (from EtOH), mp 152 °C. IR (CHCl₃): ν 1716 (C=O) cm⁻¹. ¹H NMR (300 MHz, CDCl₃): δ 7.29 (1H, td, $J = 7.5, 0.9$ Hz, arom H), 7.24 (1H, d, $J = 7.8$ Hz, arom H), 7.06 (1H, dt, $J = 7.5, 0.9$ Hz, arom H), 6.83 (1H, d, $J = 7.8$ Hz, arom H), 3.44 (1H, q, $J = 7.8$ Hz, >CH-), 3.21 (3H, s, Me), 1.48 (3H, d, $J = 7.8$ Hz, Me) ppm. ¹³C NMR (75 MHz, CDCl₃): δ 178.7 (C=O), 143.9, 130.6 (arom C), 127.8, 123.4, 122.3, 107.9 (arom CH), 40.5 (C-3), 26.1 (Me), 15.3 (Me) ppm. MS m/z (rel intensity) 161 (M+, 70), 146 (45), 132 (10), 118 (100), 91 (20).

5-Fluoro-1,3-dimethylindolin-2-one (8b). ^{16d} Yield 72%. ¹H NMR (500 MHz, CDCl₃): δ 6.99-6.95 (2H, m, arom H), 6.75-6.73 (1H, m, arom H), 3.42 (1H, q, $J = 7.5$ Hz, >CH-), 3.23 (3H, s, Me), 1.47 (3H, d, $J = 7.5$ Hz, Me) ppm. ¹³C NMR (125 MHz, CDCl₃): δ 178.0 (C=O), 159.1 (d, $J = 238.5$ Hz), 139.8, 132.1 (d, $J = 8.4$ Hz) (arom C), 113.7 (d, $J = 23.9$ Hz), 111.5 (d, $J = 23.9$ Hz), 108.2 (d, $J = 8.4$ Hz) (arom CH), 40.7 (C-3), 26.2 (Me), 15.1 (Me) ppm.

5-Chloro-1,3-dimethylindolin-2-one (8c). ²⁶ Yield 31%. Colorless prisms (from CHCl₃-hexane), mp 66 °C. IR (CHCl₃): ν 1705 (C=O) cm⁻¹. ¹H NMR (300 MHz, CDCl₃): δ 7.249 (1H, dd, $J = 8.1, 2.4$ Hz, arom H), 7.25 (1H, d, $J = 2.4$ Hz, arom H), 6.74 (1H, d, $J = 8.1$ Hz, arom H), 3.42 (1H, q, $J = 7.8$ Hz, >CH-), 3.19 (3H, s, Me), 1.47 (3H, d, $J = 7.8$ Hz, Me) ppm. ¹³C NMR (75 MHz, CDCl₃): δ 178.0 (C=O), 142.5, 132.2, 127.7 (arom C), 127.7, 124.0, 108.8 (arom CH), 40.6 (C-3), 26.3 (Me), 15.2 (Me) ppm. MS m/z (rel intensity) 197 (M+, 30), 195 (M+, 100), 180 (30), 160 (95), 152 (50), 117 (95), 89 (30). Anal. Calcd for C₁₀H₁₀ClNO: C, 61.39; H, 5.15; N, 7.16. Found: C, 61.22; H, 5.04; N, 7.05.

5-Methoxy-1,3-dimethylindolin-2-one (8g). ^{16d,27} Yield 96%. Yellow liquid. IR (CHCl₃): ν 1697 (C=O) cm⁻¹. ¹H NMR (300 MHz, CDCl₃): δ 6.86 (1H, m, arom H), 6.80 (1H, dd, $J = 8.5, 2.5$ Hz, arom H), 6.72 (1H, d, $J = 8.5$, arom H), 3.79 (3H, s, MeO), 3.39 (1H, q, $J = 7.5$ Hz, >CH-), 3.14 (3H, s, Me), 1.46 (3H, d, $J = 7.5$ Hz, Me) ppm. ¹³C NMR (75 MHz, CDCl₃): δ 178.2 (C=O), 155.9, 137.5, 132.0 (arom C), 111.9, 111.2, 108.1 (arom CH), 55.8 (MeO), 40.9 (C-3), 26.2 (Me), 15.4 (Me) ppm.

4-Methoxy-1,3-dimethylindolin-2-one (8h). ²⁸ Yield 76%. Colorless prisms (from CHCl₃-hexane), mp 70 °C. IR (CHCl₃): ν 1705 (C=O) cm⁻¹. ¹H NMR (300 MHz, CDCl₃): δ 7.22 (1H, t, $J = 8.4$ Hz, arom H), 6.62 (1H, d, $J = 8.4$ Hz, arom H), 6.47 (1H, d, $J = 8.4$ Hz, arom H), 3.84 (3H, s, MeO), 3.43 (1H, q, $J = 7.5$ Hz, >CH-), 3.16 (3H, s, Me), 1.49 (3H, d, $J = 7.5$ Hz, Me) ppm. ¹³C NMR (75 MHz, CDCl₃): δ 178.6

(C=O), 155.6, 144.8, 116.16 (arom C), 128.8, 105.3, 101.1 (arom CH), 55.0 (MeO), 39.3 (C-3), 26.0 (Me), 14.0 (Me) ppm. MS m/z (rel intensity) 191 (M+, 80), 176 (100), 148 (60), 133 (50), 117 (30), 105 (20), 91 (35), 77 (50).

1,3-Dimethyl-1*H*-benzo[*g*]indol-2(3*H*)-one (8r). Yield 63%. Colorless prisms (from CHCl₃-hexane), mp 80-81 °C. IR (CHCl₃): ν 1665 (C=O) cm⁻¹. ¹H NMR (300 MHz, CDCl₃): δ 7.71 (1H, d, J = 8.1 Hz, arom H), 7.52-7.40 (3H, m, arom H), 7.31 (1H, d, J = 7.2 Hz, arom H), 6.94 (1H, d, J = 7.5 Hz, arom H), 4.14 (1H, q, J = 7.5 Hz, >CH-), 3.50 (3H, s, Me), 1.65 (3H, d, J = 7.5 Hz, Me) ppm. ¹³C NMR (75 MHz, CDCl₃): δ 171.5 (C=O), 137.4, 135.4, 133.3, 119.3 (arom C), 126.9, 126.4, 125.8, 123.7, 122.3, 108.5 (arom CH), 41.2 (C-3), 29.3 (Me), 24.3 (Me) ppm. MS m/z (rel intensity) 211 (M+, 100), 196 (50), 168 (80), 133 (50), 127 (30), 83 (25). FAB HRMS (acetone/NBA) calcd for C₁₄H₁₃NO 211.0997 (M). Found 211.0984.

Reduction of Indolinones 7 and 8. Acetylindolinone **7** or deacetylated indolinone **8** (0.2 mmol) was dissolved in dry THF (4 mL) and cooled at 0 °C. LiAlH₄ (0.4 mmol) was added and the mixture was stirred at 0 °C for 1 h, then at room temperature for 4 h under an argon atmosphere. The reaction was quenched by adding EtOAc (1 mL) and a saturated aqueous solution of Rochelle salt (2 mL). The aqueous solution was filtered through a Celite column, washed with EtOAc, and the filtrate then concentrated dryness. The residue was separated by silica gel TLC eluting with hexane-EtOAc (95:5 v/v), giving the corresponding indole **10**.

1,3-Dimethyl-1*H*-indole (10a).^{15,29} Yield 86%. Yellow liquid. IR (CHCl₃): ν 1616 (C=C) cm⁻¹. ¹H NMR (500 MHz, CDCl₃): δ 7.56 (1H, d, J = 8.5 Hz, arom H), 7.27 (1H, d, J = 8.5 Hz, arom H), 7.21 (1H, t, J = 7.3 Hz, arom H), 7.10 (1H, t, J = 7.3 Hz, arom H), 6.82 (1H, s, H-2), 3.73 (3H, s, Me), 2.32 (3H, s, Me) ppm. ¹³C NMR (125 MHz, CDCl₃): δ 136.9, 128.6, 110.1 (arom C), 126.5, 121.4, 118.9, 118.4, 109.0 (arom CH), 32.5 (Me), 9.5 (Me) ppm.

5-Fluoro-1,3-dimethyl-1*H*-indole (10b).³⁰ Yield 69%. Yellow liquid. IR (CHCl₃): ν 1625 (C=C) cm⁻¹. ¹H NMR (500 MHz, CDCl₃): δ 7.18 (1H, dd, J = 10.0, 2.5 Hz, arom H), 7.14 (1H, dd, J = 10.0, 4.0 Hz, arom H), 6.94 (1H, dt, J = 10.0, 2.5 Hz, arom H), 6.83 (1H, s, H-2), 3.69 (3H, s, Me), 2.26 (3H, s, Me) ppm. ¹³C NMR (125 MHz, CDCl₃): δ 157.5 (d, J = 234.0 Hz), 133.6 (s), 128.8 (d, J = 9.7 Hz), 109.9 (d, J = 4.8 Hz) (arom C), 128.2 (s), 109.7 (d, J = 15.6 Hz), 109.5 (s), 103.7 (d, J = 22.9 Hz) (arom CH), 32.7 (Me), 9.4 (Me) ppm.

5-Methoxy-1,3-dimethyl-1*H*-indole (10g).³⁰ Yield 79%. IR (CHCl₃): ν 1620 (C=C) cm⁻¹. ¹H NMR (500 MHz, CDCl₃): δ 7.07 (1H, d, J = 8.5 Hz, arom H), 6.92 (1H, d, J = 2.5 Hz, arom H), 6.79 (1H, dd, J = 8.5, 2.5 Hz, arom H), 6.70 (1H, s, arom H), 3.79 (3H, s, Me), 3.60 (3H, s, Me), 2.21 (3H, s, Me) ppm. ¹³C NMR (125 MHz, CDCl₃): δ 153.6, 132.4, 128.9, 109.4 (arom C), 127.2, 111.6, 109.7, 100.8 (arom CH), 55.9 (Me), 32.6 (Me), 9.5 (Me) ppm.

ACKNOWLEDGEMENTS

This research was supported by a Grant-in-Aid for Scientific Research (C), No. 25410049, from the Japan Society for the Promotion of Science, and also by the 2013-Core Research Program, "Integrated Science for Molecular Chirality in Biology and Chemistry," Graduate School of Science and Technology, Kumamoto University, Japan. We gratefully acknowledge Nissan Chemical Industries, Ltd., for financial support. HN thanks Mr. Shin-tarou Hashimoto and Mr. Shin-ji Tadano, Department of Science, Faculty of Science, Kumamoto University, Japan, for their technical assistance.

REFERENCES

1. a) J. A. Joule and K. Mills, 'Heterocyclic Chemistry,' 5th ed., Wiley, Chichester, 2010; b) R. J. Sundberg, 'The Chemistry of Indoles,' Academic Press, Inc., New York, 1970; c) B. Robinson, 'Fischer Indole Synthesis,' Wiley, Chichester, 1982; d) R. J. Sundberg, 'Indoles,' Academic Press, Inc., London, 1996; e) D. L. Hughes, *Org. Prep. Proc. Int.*, **1993**, **25**, 607.
2. a) U. Pindur and H. Erfanian-Abdoust, *Chem. Rev.*, **1989**, **89**, 1681; b) G. R. Humphrey and J. T. Kuethe, *Chem. Rev.*, **2006**, **106**, 2875; c) S. Cacchi and G. Fabrizi, *Chem. Rev.*, **2005**, **105**, 2873; d) M. Shiri, *Chem. Rev.*, **2012**, **112**, 3508; e) A. W. Schmidt, K. R. Reddy, and H.-J. Knölker, *Chem. Rev.*, **2012**, **112**, 3193; f) G. H. Kirsch, *Curr. Org. Chem.*, **2001**, **5**, 507.
3. a) S. Tadano, Y. Mukaeda, and H. Ishikawa, *Angew. Chem. Int. Ed.*, **2013**, **52**, 7990; b) E. D. Styduhar, A. D. Hutters, N. A. Weires, and N. K. Garg, *Angew. Chem. Int. Ed.*, **2013**, **52**, 1; c) G. G. A. Cordell, 'The Alkaloids: Chemistry and Biology,' Vol. 60, Elsevier, San Diego, 2003; d) W. Fröhner, M. P. Krahl, K. R. Reddy, and H.-J. Knölker, *Heterocycles*, **2004**, **63**, 2393.
4. a) G. A. Cordell and J. E. Saxton, 'The Alkaloids: Chemistry and Physiology,' Vol. 20, Academic Press, Inc., New York, 1981, pp. 3–295; b) T. Hino and M. Nakagawa, 'The Alkaloids: Chemistry and Pharmacology,' Vol. 34, ed. by A. Brossi, Academic Press, Inc., New York, 1989, pp. 1–75; c) U. Pindur and T. Lemster, *Recent Res. Dev. Org. Bioorg. Chem.*, **1997**, **1**, 33.
5. a) T. Tsuchimoto, H. Matsubayashi, M. Kaneko, Y. Nagase, T. Miyamura, and E. Shirakawa, *J. Am. Chem. Soc.*, **2008**, **130**, 15823; b) Y. Ooyama, Y. Shimada, Y. Kagawa, I. Imae, and Y. Harima, *Org. Biomol. Chem.*, **2007**, **5**, 2046; c) K. Kawaguchi, K. Nakano, and K. Nozaki, *J. Org. Chem.*, **2007**, **72**, 5119; d) N.-K. Kim, K.-J. Chang, D. Moon, M. S. Jah, and K.-S. Jeong, *Chem. Commun.*, **2007**, 3401.
6. a) Z.-Q. Cong and H. Nishino, *Synthesis*, **2008**, 2686; b) Z.-Q. Cong and H. Nishino, *Heterocycles*, **2009**, **78**, 397.
7. a) H. Nishino, H. Kamachi, H. Baba, and K. Kurosawa, *J. Org. Chem.*, **1992**, **57**, 3551; b) Z.-Q. Cong, T. Miki, O. Urakawa, and H. Nishino, *J. Org. Chem.*, **2009**, **74**, 3978; c) Y. Maemura, Y.

- Tanoue, and H. Nishino, *Heterocycles*, 2012, **85**, 2491.
8. a) T. Tsubusaki and H. Nishino, *Heterocycl. Commun.*, 2009, **15**, 79; b) T. Tsubusaki and H. Nishino, *Tetrahedron*, 2009, **65**, 9448.
 9. K. Kurosawa, *Bull. Chem. Soc. Jpn.*, 1969, **42**, 1456.
 10. a) B. B. Snider, *Chem. Rev.*, 1996, **96**, 339; b) G. G. Melikyan, *Org. React.*, 1997, **49**, 427; c) A. S. Demir and M. Emrullahoglu, *Curr. Org. Synth.*, 2007, **4**, 321; d) X.-Q. Pan, J.-P. Zou, and W. Zhang, *Mol. Divers.*, 2009, **13**, 421; e) K. Asahi and H. Nishino, *Tetrahedron*, 2008, **64**, 1620; f) Y. Ito, S. Jogo, N. Fukuda, R. Okumura, and H. Nishino, *Synthesis*, 2011, 1365; g) H. Nishino, R. Kumabe, R. Hamada, and M. Yakut, *Tetrahedron*, 2014, **70**, 1437.
 11. B. B. Snider, *Tetrahedron*, 2009, **65**, 10738.
 12. a) I. H. Bowen, P. Gupta, M. S. Khan, and J. R. Lewis, *J. Chem. Soc., Perkin Trans. 1*, 1972, 2554; b) B. Rindone and C. Scolastico, *Tetrahedron Lett.*, 1974, **15**, 3379; c) G. Galliani, B. Rindone, and C. Scolastico, *Tetrahedron Lett.*, 1975, **16**, 1285; d) H. Nishino and K. Kurosawa, *Bull. Chem. Soc. Jpn.*, 1983, **56**, 1682.
 13. K. Asahi and H. Nishino, *Synthesis*, 2009, 409.
 14. a) J. E. Thomson, A. F. Kyle, K. B. Ling, S. R. Smith, A. M. Z. Slawin, and A. D. Smith, *Tetrahedron*, 2010, **66**, 3801; b) M. M. Bostos, L. M. U. Mayer, E. C. S. Figueira, M. Soares, W. B. Kover, and N. Boechat, *J. Heterocycl. Chem.*, 2008, **45**, 969; c) S. J. Garden, R. B. de Silva, and A. C. Pinto, *Tetrahedron*, 2002, **58**, 8399; d) W. Wierenga, J. Griffin, and M. A. Warpehoski, *Tetrahedron Lett.*, 1983, **24**, 2437; e) A. Kubo and T. Nakai, *Synthesis*, 1980, 365.
 15. P. L. Julian and H. C. Printy, *J. Am. Chem. Soc.*, 1949, **71**, 3206.
 16. a) B. Li, Y. Park, and S. Chang, *J. Am. Chem. Soc.*, 2014, **136**, 1125; b) Y. Yang, J. Han, X. Wu, S. Mao, J. Yu, and L. Wang, *Synlett*, 2014, **25**, 1419; c) J.-H. Fan, M.-B. Zhou, Y. Liu, W.-T. Wei, X.-H. Ouyang, R.-J. Song, and J.-H. Li, *Synlett*, 2014, **25**, 657; d) C. Liu, D. Liu, W. Zhang, L. Zhou, and A. Lei, *Org. Lett.*, 2013, **15**, 6166; e) J. Wang, Y. Yuan, R. Xiong, D. Zhang-Negrerie, Y. Du, and K. Zhao, *Org. Lett.*, 2012, **14**, 2210; f) D. Qian and J. Zhang, *Chem. Commun.*, 2012, **48**, 7082; g) X. Ju, Y. Liang, P. Jia, W. Li, and W. Yu, *Org. Boimol. Chem.*, 2012, **10**, 4981; h) W.-W. Chan, T.-L. Kwong, and W.-Y. Yu, *Org. Boimol. Chem.*, 2012, **10**, 3749; i) H.-L. Wang, Z. Li, G.-W. Wang, and S.-D. Yang, *Chem. Commun.*, 2011, **47**, 11336; j) Z. Yu, L. Ma, and W. Yu, *Synlett*, 2010, **17**, 2607; k) B. Zaleska and S. Lis, *Synth. Commun.*, 2001, **31**, 189; l) B. S. Gerstenberger, J. Lin, Y. S. Mimieux, L. E. Brown, A. G. Oliver, and J. P. Konopelski, *Org. Lett.*, 2008, **10**, 369; m) B. Lu and D. Ma, *Org. Lett.*, 2006, **8**, 6115; n) C. Leroi, D. Bertin, P.-E. Dufils, D. Gignes, S. Marque, P. Tordo, J.-L. Couturier, O. Guerret, and M. A. Ciufolini, *Org. Lett.*, 2003, **5**, 4943; o) D. Li and W. Yu, *Adv. Synth. Catal.*, 2013, **355**, 3708.

17. P. J. Andrus, Jr., M. J. S. Dewar, R. Dietz, and R. L. Hunt, *J. Am. Chem. Soc.*, 1966, **88**, 5473.
18. E. I. Heiba, R. M. Dessau, and W. J. Koehl, Jr., *J. Am. Chem. Soc.*, 1969, **91**, 138.
19. D. J. Cook and W. C. Lawall, *J. Am. Chem. Soc.*, 1948, **70**, 1918.
20. M. Sato, H. Ogasawara, S. Komatsu, and T. Kato, *Chem. Pharm. Bull.*, 1984, **32**, 3848.
21. C.-Y. Qian, H. Nishino, and K. Kurosawa, *Bull. Chem. Soc. Jpn.*, 1991, **64**, 3557.
22. T. Hino, *Chem. Pharm. Bull.*, 1961, **9**, 979.
23. a) Y. K. Voronina, D. B. Krivolapov, A. V. Bogdanov, V. F. Mironov, and I. A. Litvinov, *J. Struct. Chem.*, 2012, **53**, 413; b) J. Bergman and I. Romero, *J. Heterocycl. Chem.*, 2010, **47**, 1215; c) A. V. Bogdanov, V. F. Mironov, L. I. Musin, and R. Z. Musin, *Synthesis*, 2010, 3268; d) X. K. Wee, W. K. Yeo, B. Zhang, V. B. C. Tan, K. M. Lim, T. E. Tay, and M.-L. Go, *Bioorg. Med. Chem.*, 2009, **17**, 7562.
24. a) A. M. Taylor, R. A. Altman, and S. L. Buchwald, *J. Am. Chem. Soc.*, 2009, **131**, 9900; b) L. Wang, Y. Su, X. Xu, and W. Zhang, *Eur. J. Org. Chem.*, 2012, 6606.
25. a) Y.-M. Li, X.-H. Wei, and S.-D. Yang, *Chem. Commun.*, 2013, **49**, 11701; b) L. Cheng, L. Liu, D. Wang, and Y.-J. Chen, *Org. Lett.*, 2009, **11**, 3874.
26. a) T. Kato, A. Inada, Y. Morita, and H. Miyamae, *Chem. Pharm. Bull.*, 1985, **33**, 5270; b) R. Underwood, K. Prasad, O. Repic, and G. E. Hardtmann, *Synth. Commun.*, 1992, **22**, 343.
27. a) B. M. Trost and Y. Zhang, *Chem. Eur. J.*, 2011, **17**, 2919; b) Q.-S. Yu, W. Luo, H. W. Holloway, T. Utski, T. A. Perr, D. K. Lahiri, N. H. Greig, and A. Brossi, *Heterocycles*, 2003, **61**, 529.
28. E. Glamkowski and B. E. Kurys, *Can. Pat. Appl.*, 1991, CA 2029265 A1 19910504.
29. a) M. Mori, S. Kudo, and Y. Ban, *J. Chem. Soc., Perkin Trans. 1*, 1979, 771; b) T. Nishida, Y. Tokuda, and M. Tsuchiya, *J. Chem. Soc., Perkin Trans. 2*, 1995, 823; c) M. Kihara, Y. Iwai, and Y. Nagao, *Heterocycles*, 1995, **41**, 2279.
30. a) L. M. Repka, J. Ni, and S. E. Reisman, *J. Am. Chem. Soc.*, 2010, **132**, 14418; b) J. E. Spangler and H. M. L. Davies, *J. Am. Chem. Soc.*, 2013, **135**, 6802; c) J. Ni, H. Wang, and S. E. Reisman, *Tetrahedron*, 2013, **69**, 5622; d) Y.-M. Su, Y. Hou, F. Yin, Y.-M. Xu, Y. Li, X. Zheng, and X.-S. Wang, *Org. Lett.*, 2014, **16**, 2958.