

HETEROCYCLES, Vol. 97, No. 2, 2018, pp. 894 - 915. © 2018 The Japan Institute of Heterocyclic Chemistry  
Received, 15th February, 2018, Accepted, 9th April, 2018, Published online, 19th April, 2018  
DOI: 10.3987/COM-18-S(T)67

## TANDEM OXIDATION/CYCLIZATION REACTION OF 4-(ARYLMETHYL)OXY-2-DIAZOBUTYRATE DERIVATIVES<sup>†</sup>

Hideaki Kondo, Shuji Nagano, Hiroyuki Yamakoshi, and Seiichi Nakamura\*

Graduate School of Pharmaceutical Sciences, Nagoya City University, 3-1 Tanabe-dori, Mizuho-ku, Nagoya 467-8603, Japan; E-mail: nakamura@phar.nagoya-cu.ac.jp

**Abstract** – A tandem oxidation/cyclization reaction of  $\gamma$ -(arylmethyl)oxy- $\alpha$ -diazobutyrate derivatives was investigated. While oxidative cleavage of the PMB ether was only observed upon treatment of an  $\alpha$ -diazo- $\beta$ -ketoester with DDQ, oxidation of  $\alpha$ -diazo esters with an  $sp^3$  carbon at the  $\beta$ -position was accompanied by intramolecular attack of the diazo carbon atom and expulsion of the nitrogen gas to give 2,3-dihydrofurans in modest to good yields when an electron-withdrawing group was substituted at the  $\beta$ -position. Substrates bearing no electron-withdrawing  $\beta$ -substituent were found to give rearranged products, albeit in modest yields. A benzofuran derivative could also be obtained, although a hydroquinone adduct was formed as a byproduct.

### INTRODUCTION

Since the preparation of ethyl diazoacetate in 1883, diazo compounds have frequently been used in organic synthesis due to their high versatility and synthetic utility.<sup>1</sup> These compounds have long been recognized as 1,3-dipoles, cycloaddition of which with dipolarophiles provides pyrazoline derivatives.<sup>2</sup> Carbene species can be generated by expulsion of nitrogen gas upon exposure to heat or light,<sup>3</sup> whereas transition metal-catalyzed diazo decomposition produces metal carbenoids, which can participate in a wide variety of reactions such as cyclopropanation, X–H insertion, and ylide formation.<sup>4</sup> It is also well known that diazo compounds undergo both electrophilic and nucleophilic reactions; the electrophilic capability of the terminal nitrogen atom allows reaction with highly reactive carbon nucleophiles,<sup>5</sup> and the negatively polarized diazo carbon atom is sufficiently nucleophilic to react with electrophiles such as proton, aldehydes and imines.<sup>6</sup>

While  $\alpha$ -diazo carbonyl compounds are easily deprotonated under basic conditions, their inherent nucle-

<sup>†</sup> Dedicated to Professor Kiyoshi Tomioka on the occasion of his 70th birthday

ophilicity comparable to that of silyl enol ethers<sup>7</sup> allows reaction with carbonyl compounds with the aid of an appropriate Lewis acid. Roskamp reaction, in which Lewis acid-catalyzed generation of diazonium intermediates from  $\alpha$ -diazo esters and aldehydes is followed by an expulsion of nitrogen and subsequent 1,2-hydride shift to provide  $\beta$ -ketoesters, is representative of this type of transformation (Scheme 1).<sup>8</sup> It

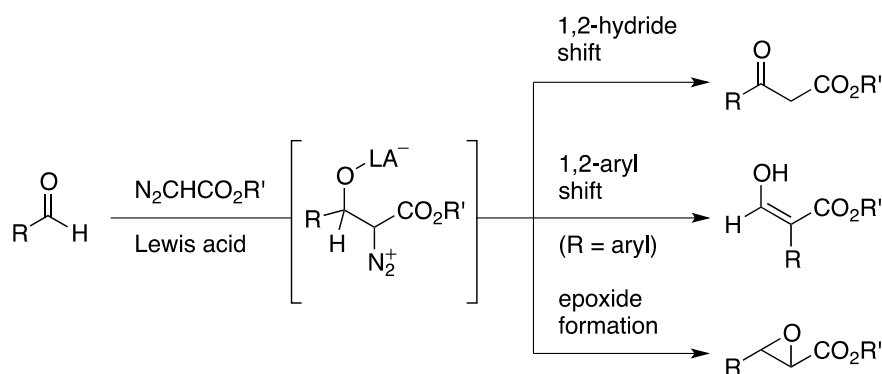

**Scheme 1.** Lewis acid-catalyzed reactions of aldehydes with  $\alpha$ -diazoacetates

has also been reported that the use of some Lewis acids in the reaction with aromatic aldehydes led to the preferential formation of  $\alpha$ -formyl ester via 1,2-aryl migration,<sup>9</sup> whereas epoxide formation via Darzens-type reaction occurred by the action of  $\text{MeReO}_3$  or  $\text{La}(\text{OTf})_3$ .<sup>10</sup> In 2009, Doyle and Zhou developed an intramolecular variant of the Lewis acid-catalyzed reaction in which either  $\text{Zn}(\text{OTf})_2$  or  $\text{BF}_3 \cdot \text{OEt}_2$  was employed for the activation of iminodiazooacetates and elimination occurred instead of rearrangement to give indoles in quantitative yields (Scheme 2).<sup>11</sup>

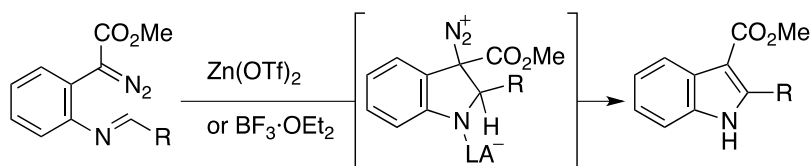

**Scheme 2.** Lewis acid-catalyzed cyclization of iminodiazooacetates

During the course of our studies on second-generation synthesis of zaragozic acids,<sup>12</sup> we found that our attempt to remove the PMB protecting group in  $\alpha$ -diazo ester **1** with DDQ<sup>13,14</sup> met with failure but resulted in the formation of 2,3-dihydrofuran **2** in 64% yield even in the presence of pH 7 phosphate buffer (Scheme 3). This result clearly revealed that the oxidative generation of oxocarbenium ions can trigger the cyclization of diazo compounds, and that intramolecular attack of the diazo carbon atom proceeded faster than hydrolysis of oxocarbenium ion **3** to provide diazonium intermediate **4**. In this paper, we document the scope and limitations of the tandem oxidation/cyclization reaction using  $\alpha$ -diazo esters as substrates.<sup>15</sup>

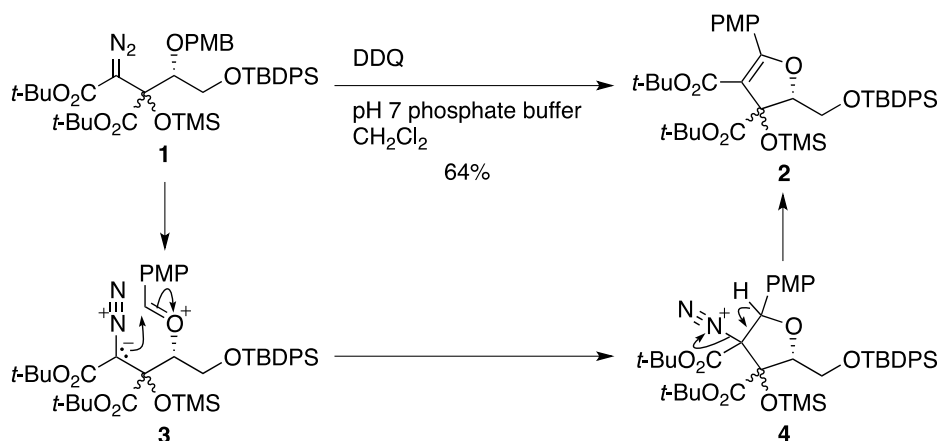

**Scheme 3.** Unexpected 2,3-dihydrofuran formation from  $\alpha$ -diazo ester **1**

## RESULTS AND DISCUSSION

Since the nucleophilicity of the diazo carbon atom can be regulated by adjacent substituents,  $\alpha$ -diazo- $\beta$ -ketoester **5** and  $\alpha$ -diazo ester **6a** were chosen as substrates for optimization of the reaction parameters due their ease of preparation (Scheme 4).  $\alpha$ -Diazo- $\beta$ -ketoester **5** was obtained by a two-step sequence involving coupling of aldehyde **7**<sup>16</sup> with *tert*-butyl diazoacetate according to the Wenkert procedure<sup>17</sup> (47% yield) and oxidation with IBX<sup>18</sup> in the presence of pyridine (81% yield). On the other hand, the synthesis of  $\alpha$ -diazo ester **6a** commenced with mono-alkylation of commercially available L-(+)-glycerate (**9**)<sup>19</sup> with PMBI via the stannylene acetal,<sup>20</sup> affording PMB ether **10** in 57% yield. After oxidation of the remaining secondary alcohol with IBX (84% yield),  $\alpha$ -diazo ester functionality was installed as with **7** and subsequent protection of the resultant alcohol with HMDS completed the preparation of  $\alpha$ -diazo ester **6a** in 42% yield in two steps.

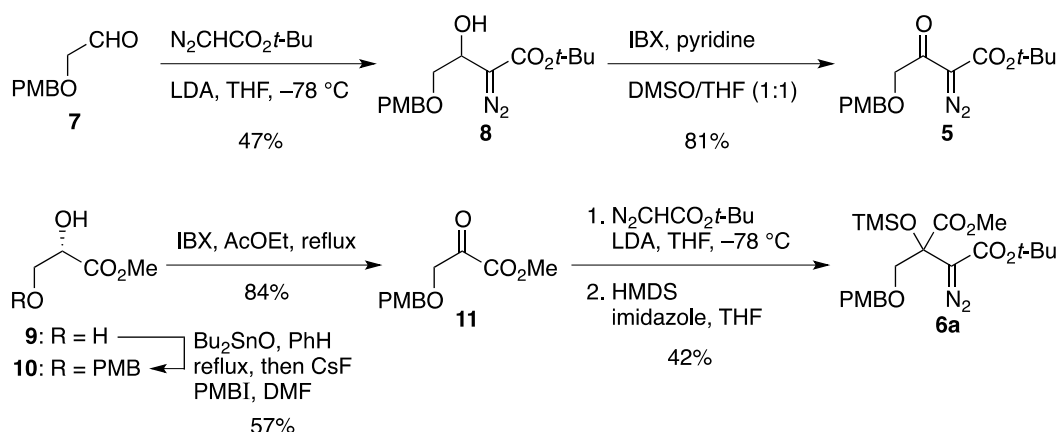

**Scheme 4.** Preparation of diazo compounds **5** and **6a**

With substrates **5** and **6a** in hand, we then proceeded to investigate the cyclization reaction. We initially explored the reaction of  $\alpha$ -diazo- $\beta$ -ketoester **5**, but exposure of **5** to DDQ in  $\text{CH}_2\text{Cl}_2$  resulted, after aque-

ous workup, only in cleavage of the PMB ether, leaving the diazo group intact (Scheme 5). This result suggested that the diazo carbon stabilized by two electron-withdrawing groups did not possess sufficient nucleophilicity to participate in the projected intramolecular addition reactions.

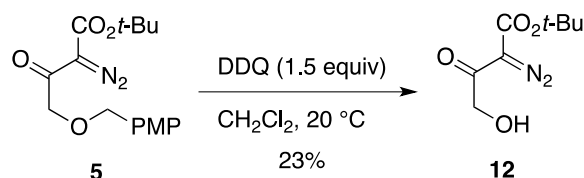

**Scheme 5.** Oxidation of  $\alpha$ -diazo- $\beta$ -ketoester **5** with DDQ

On the other hand, the desired five-membered ring formation could be achieved by the use of more nucleophilic  $\alpha$ -diazo ester **6a** instead of **5** as a substrate, providing 2,3-dihydrofuran **14a** in 79% yield (Table 1, entry 1). Encouraged by this result, oxidants other than DDQ were next screened for their ability to promote the tandem reaction. It was found that *o*-chloranil and 2,3-dichloro-1,4,5,8-naphthalenetetrone (DCINTO)<sup>21</sup> furnished cyclization product **14a**, albeit in low yields (entries 2 and 4), whereas a complex mixture was obtained by the use of *p*-chloranil, tritylium tetrafluoroborate, and tropylium tetrafluoroborate (entries 3, 5 and 6). We were concerned that the cyclization would compete with hydrolysis by adventitious water, but a beneficial effect was not observed with 4 Å MS (entry 7). While LiClO<sub>4</sub> was

**Table 1.** Effects of oxidants and additives in the tandem reaction with  $\alpha$ -diazo ester **6a**<sup>a</sup>

entry	oxidant	additive	solvent	temp, °C	time, h	yield, %
1	DDQ	—	CH <sub>2</sub> Cl <sub>2</sub>	20	3	79
2	<i>o</i> -chloranil	—	CH <sub>2</sub> Cl <sub>2</sub>	20	48	7
3	<i>p</i> -chloranil	—	PhCl	100	3	0
4	DCINTO	—	PhCl	80	24	30
5	Ph <sub>3</sub> C <sup>+</sup> BF <sub>4</sub> <sup>-</sup>	—	CH <sub>2</sub> Cl <sub>2</sub>	-40	14	0
6	C <sub>7</sub> H <sub>7</sub> <sup>+</sup> BF <sub>4</sub> <sup>-</sup>	—	CH <sub>2</sub> Cl <sub>2</sub>	20	4	0
7	DDQ	4 Å MS	CH <sub>2</sub> Cl <sub>2</sub>	20	3	73
8	DDQ	LiClO <sub>4</sub>	CH <sub>2</sub> Cl <sub>2</sub>	20	3	69
9	DDQ	Na <sub>2</sub> CO <sub>3</sub>	CH <sub>2</sub> Cl <sub>2</sub>	20	3	71

<sup>a</sup> The reaction was carried out on a 50-mg scale.

reported to enhance the reactivity of oxocarbenium species,<sup>22,23</sup> addition of LiClO<sub>4</sub> or Na<sub>2</sub>CO<sub>3</sub> resulted in slightly reduced yields (entries 8 and 9).

We next undertook a solvent survey in the DDQ-promoted tandem reaction (Table 2), and CH<sub>2</sub>Cl<sub>2</sub> proved to be the solvent of choice for this transformation in terms of both product yield and reaction rate (entry 1). While the use of Et<sub>2</sub>O and chlorobenzene afforded 2,3-dihydrofuran **14a** in good yields (69% and 70%, respectively), these reactions required longer times to reach completion (entries 2 and 3). The use of solvents such as toluene and MeCN led to a significant reduction in the chemical yield (entries 4 and 5). The reaction in CH<sub>2</sub>Cl<sub>2</sub> was found to proceed even at -20 °C, but a decline in the yield (79% → 62%), as well as rate retardation, was observed (entry 6).

**Table 2.** Effects of solvent and temperature in the cyclization<sup>a</sup>

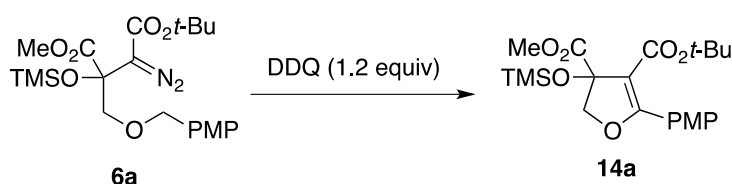

entry	solvent	temp, °C	time, h	yield, %
1	CH <sub>2</sub> Cl <sub>2</sub>	20	3	79
2	Et <sub>2</sub> O	20	16	69
3	PhCl	20	7	70
4	toluene	20	45	46
5	MeCN	20	4	34
6	CH <sub>2</sub> Cl <sub>2</sub>	-20	70	62

<sup>a</sup> The reaction was carried out on a 50-mg scale.

With the reaction conditions optimized, the scope of the tandem oxidation/cyclization reaction was then investigated (Scheme 6). Although the reason is not clear at present, the reaction of *tert*-butyl ester **6a** proceeded faster (3 h vs 5 h) and afforded a slightly higher yield (79% vs 72%) than that of ethyl ester **6b**. As anticipated from the report by Yonemitsu and co-workers,<sup>24,25</sup> the order of reactivity of the arylmethyl moiety was 3,4-(MeO)<sub>2</sub>C<sub>6</sub>H<sub>3</sub>CH<sub>2</sub> (**6c**) > 4-MeOC<sub>6</sub>H<sub>4</sub>CH<sub>2</sub> (**6a**) > 3,4,5-(MeO)<sub>2</sub>C<sub>6</sub>H<sub>2</sub>CH<sub>2</sub> (**6d**) > 2-MeO-C<sub>6</sub>H<sub>4</sub>CH<sub>2</sub> (**6e**) > 3-MeOC<sub>6</sub>H<sub>4</sub>CH<sub>2</sub> (**6f**) > C<sub>6</sub>H<sub>5</sub>CH<sub>2</sub> (**6g**), and the reaction of benzyl ether **6g** was sluggish even at 80 °C in chlorobenzene (22% yield). While 3,4-(methylenedioxy)phenyl-, 2-naphthyl- and 4-acetamidophenyl-substituted 2,3-dihydrofurans **14h–j** could also be obtained in good yields, treatment of allyl ether **6k** with DDQ resulted only in decomposition (chlorobenzene, 80 °C). Introduction of an alkyl group(s) on the oxygen-substituted carbon atom facilitated the oxidative generation of oxocarbenium ions

(**6m** > **6l** > **6a**), allowing for the cyclization of benzyl ether **6n** to occur even at 20 °C.<sup>26</sup> The *gem*-

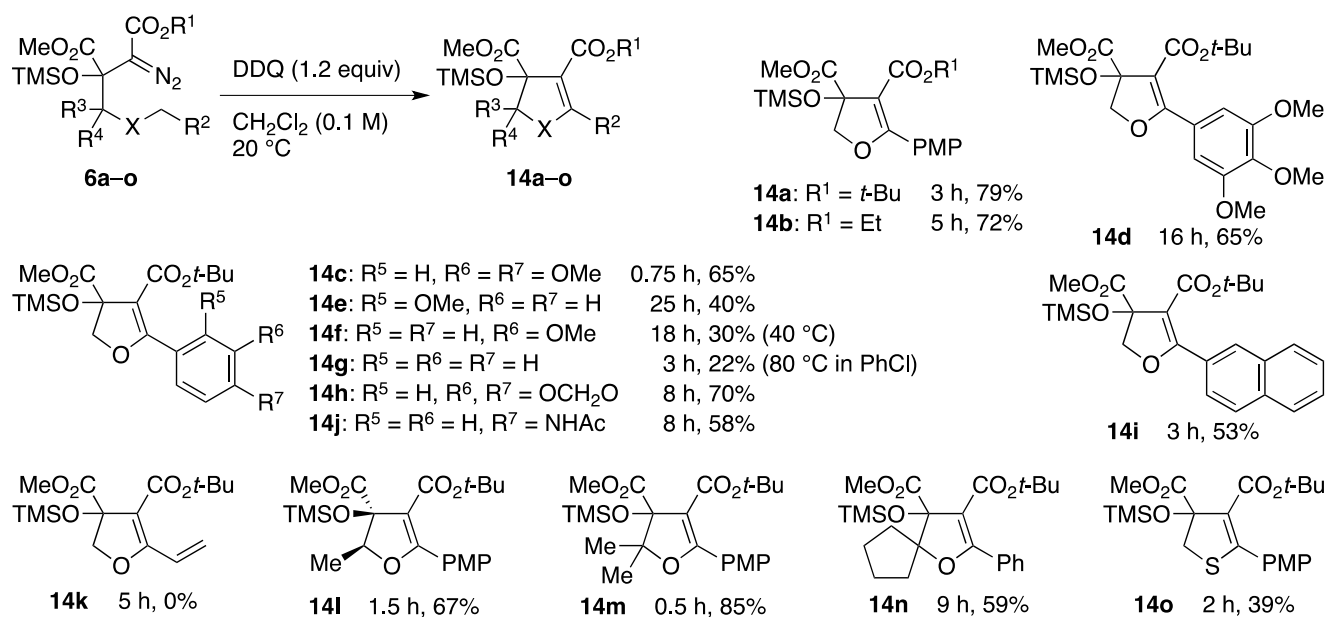

**Scheme 6.** DDQ-promoted cyclization of  $\alpha$ -diazo esters **6a–o**

dimethyl moiety in **14m** is clearly exerting a Thorpe–Ingold effect, and fully substituted 2,3-dihydrofuran **14m** could be obtained in the highest yield of 85%. Under the optimized conditions, sulfide **6o** could also be employed as a substrate, albeit the yield was modest (39%).<sup>27</sup>

It is speculated that the methoxycarbonyl group at the  $\beta$  position would be reluctant to undergo 1,2-migration, thus leading to the exclusive formation of 2,3-dihydrofuran derivatives. In order to determine whether 1,2-migration could compete with  $\beta$ -elimination, the substituent at the  $\beta$  position was next varied (Table 3). As with ester **6a**, elimination product **14p** was obtained upon treatment of  $\alpha$ -diazo- $\beta$ -cyano ester **6p** with DDQ in CH<sub>2</sub>Cl<sub>2</sub> at 20 °C, with no discernible formation of a migration product **15p** (entry 2). In contrast, DDQ-promoted oxocarbenium ion formation from PMB ethers **6q** and **6r** was accompanied by sequential cyclization and 1,2-migration, furnishing  $\beta$ -ketoesters **15q** and **15r** as single diastereomers (entries 3 and 5). While a trend for the chemical yield to increase with decrease in temperature was observed, the temperature limit for the reaction was –30 °C, at which  $\beta$ -ketoesters **15q** and **15r** were obtained in only 35% and 21% yields, respectively (entries 4 and 6). It should be mentioned that elimination products **14q** and **14r** could not be isolated in these cases. The stereochemistry of  $\beta$ -ketoester **15r**, which was determined by a NOESY experiment, indicates that the migration product **15r** would be formed from diazonium intermediate **16**, one of the four possible diastereomeric intermediates, whereas the exclusive formation of the *trans*-isomer **15q** would be a consequence of epimerization. The low conversion to **15q** and **15r** could be attributed to the nonselective cyclization.<sup>28</sup>

It was anticipated that the present protocol could be extended to the preparation of benzofurans. However,

desired benzofuran **18** was obtained in low yield (16%) upon exposure of aryldiazoacetate **17**<sup>29</sup> to DDQ in

**Table 3.** Effect of the substituent at the  $\beta$  position<sup>a</sup>

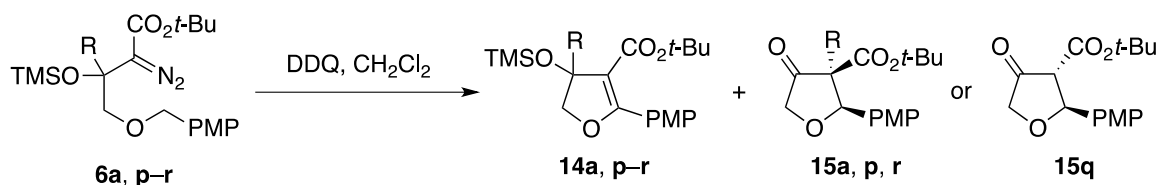

entry	substrate		temp, °C	time, h	2,3-dihydrofuran		$\beta$ -ketoester	
	R				yield, %		yield, %	
1	<b>6a</b>	CO <sub>2</sub> Me	20	3	<b>14a</b>	79	<b>15a</b>	0
2	<b>6p</b>	CN	20	6	<b>14p</b>	58	<b>15p</b>	0
3	<b>6q</b>	H	20	1	<b>14q</b>	0	<b>15q</b>	11
4	<b>6q</b>	H	-30	43	<b>14q</b>	0	<b>15q</b>	35
5	<b>6r</b>	Me	0	0.2	<b>14r</b>	0	<b>15r</b>	8
6	<b>6r</b>	Me	-30	24	<b>14r</b>	0	<b>15r</b>	21

<sup>a</sup> The reaction was carried out on a 50-mg scale.

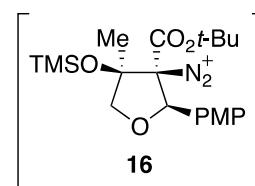

CH<sub>2</sub>Cl<sub>2</sub> at 20 °C, hydroquinone adduct **19** being formed as a byproduct (Scheme 7). This result is attributed to the high nucleophilicity of the diazo carbon atom in  $\alpha$ -diazo ester **17**.

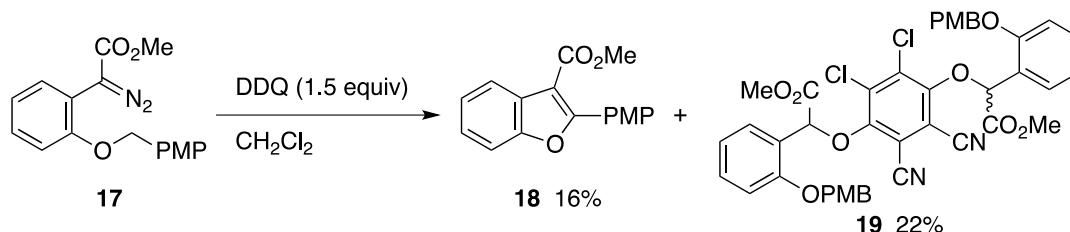

**Scheme 7.** Benzofuran formation from aryldiazoacetate **17**

In summary, oxidative cyclization of  $\gamma$ -(arylmethyl)oxy- $\alpha$ -diazobutyrate derivatives has been documented. We found that the compatibility of  $\alpha$ -diazo esters with DDQ enabled the oxidative generation of oxocarbenium ions from 4-(arylmethyl)oxy-2-diazobutyrate, which underwent intramolecular attack of the diazo carbon atom and subsequent  $\beta$ -elimination to give 5-aryl-2,3-dihydrofuran-4-carboxylates in modest to good yields. In particular, tertiary arylmethyl ethers offer the advantages of enhanced reactivity

toward DDQ and higher product yields. The possibility of performing tandem cyclization/semipinacol rearrangements can be presented by employing substrates bearing no electron-withdrawing  $\beta$ -substituent, although the chemical yields need to be improved. This protocol represents the first example of oxidative cyclization of diazo compounds that proceeds through diazonium intermediates.

## EXPERIMENTAL

***tert*-Butyl 2-Diazo-3-hydroxy-4-[(4-methoxybenzyl)oxy]butanoate (8).** BuLi in *n*-hexane (1.51 M, 1.10 mL, 1.67 mmol) was added to a cooled ( $-78\text{ }^{\circ}\text{C}$ ) solution of diisopropylamine (0.27 mL, 1.94 mmol) in THF (5 mL), and the mixture was stirred at  $0\text{ }^{\circ}\text{C}$  for 10 min. The solution of LDA in THF/*n*-hexane thus obtained was added to a cooled ( $-78\text{ }^{\circ}\text{C}$ ) mixture of aldehyde **7**<sup>16</sup> (200 mg, 1.11 mmol) and *tert*-butyl diazoacetate (0.25 mL, 1.95 mmol) in THF (5 mL). After 2 h of stirring, the reaction was quenched with saturated aqueous  $\text{NH}_4\text{Cl}$  (10 mL), and the resulting mixture was partitioned between AcOEt (10 mL) and  $\text{H}_2\text{O}$  (10 mL). The aqueous layer was extracted with AcOEt ( $2 \times 10\text{ mL}$ ), and the combined organic extracts were washed with brine (15 mL) and dried over anhydrous  $\text{Na}_2\text{SO}_4$ . Filtration and evaporation in vacuo furnished crude product (501 mg, brown oil), which was purified by column chromatography (silica gel 15 g, 3:1 *n*-hexane/AcOEt) to give alcohol **8** (169 mg, 47%) as a pale yellow oil.  $R_f$  0.36 (3:1 *n*-hexane/AcOEt); IR (neat) 3443, 2978, 2934, 2095, 1682, 1514, 1369, 1302, 1250, 1173, 1130, 1069, 1036  $\text{cm}^{-1}$ ;  $^1\text{H}$  NMR (500 MHz,  $\text{CDCl}_3$ )  $\delta$  1.47 (s, 9H,  $\text{C}(\text{CH}_3)_3$ ), 2.85 (br s, 1H, OH), 3.59 (dd,  $J = 6.2, 9.7\text{ Hz}$ , 1H, one of  $\text{PMBOCH}_2$ ), 3.65 (dd,  $J = 4.9, 9.7\text{ Hz}$ , 1H, one of  $\text{PMBOCH}_2$ ), 3.81 (s, 3H,  $\text{OCH}_3$ ), 4.50 (s, 2H,  $\text{ArCH}_2\text{O}$ ), 4.75 (br m, 1H,  $\text{CHOH}$ ), 6.89 (d,  $J = 8.6\text{ Hz}$ , 2H,  $\text{Ar-H}$ ), 7.25 (d,  $J = 8.6\text{ Hz}$ , 2H,  $\text{Ar-H}$ );  $^{13}\text{C}$  NMR (125 MHz,  $\text{CDCl}_3$ )  $\delta$  28.3 ( $\text{CH}_3$ ), 55.2 ( $\text{CH}_3$ ), 65.1 (CH), 71.1 ( $\text{CH}_2$ ), 73.1 ( $\text{CH}_2$ ), 81.7 (C), 113.8 (CH), 129.39 (C), 129.45 (CH), 159.3 (C), 165.6 (C); HRMS (ESI)  $m/z$   $[\text{M} + \text{Na}]^+$  calcd for  $\text{C}_{16}\text{H}_{22}\text{N}_2\text{O}_5\text{Na}$  345.1421; found 345.1427.

***tert*-Butyl 2-Diazo-4-[(4-methoxybenzyl)oxy]-3-oxobutanoate (5).** A mixture of alcohol **8** (437 mg, 1.36 mmol) and pyridine (1.65 mL, 20.4 mmol) in THF (7 mL) was added to a solution of IBX (1.14 g, 4.08 mmol) in DMSO (7 mL). After 3 h of stirring, the reaction mixture was diluted with  $\text{H}_2\text{O}$  (15 mL) at  $0\text{ }^{\circ}\text{C}$  and passed through a Celite pad. The filtrate was extracted with AcOEt ( $3 \times 15\text{ mL}$ ), and the combined organic extracts were washed with brine (15 mL) and dried over anhydrous  $\text{Na}_2\text{SO}_4$ . Filtration and evaporation in vacuo furnished the crude product (880 mg, light yellow oil), which was purified by column chromatography (silica gel 20 g, 3:1 *n*-hexane/AcOEt) to give  $\alpha$ -diazo- $\beta$ -ketoester **5** (351 mg, 81%) as a pale yellow solid.  $R_f$  0.48 (3:1 *n*-hexane/AcOEt); mp  $96\text{--}97\text{ }^{\circ}\text{C}$  (pale yellow plates from 5:1 *n*-hexane/AcOEt); IR (KBr) 2980, 2864, 2837, 2127, 1707, 1674, 1516, 1373, 1317, 1304, 1254, 1236, 1148, 1132, 1051, 993, 839, 817, 781  $\text{cm}^{-1}$ ;  $^1\text{H}$  NMR (500 MHz,  $\text{CDCl}_3$ )  $\delta$  1.49 (s, 9H,  $\text{C}(\text{CH}_3)_3$ ), 3.76 (s, 3H,  $\text{OCH}_3$ ), 4.54 (s, 2H,  $\text{OCH}_2$ ), 4.56 (s, 2H,  $\text{OCH}_2$ ), 6.87 (d,  $J = 8.4\text{ Hz}$ , 2H,  $\text{Ar-H}$ ), 7.30 (d,  $J = 8.4\text{ Hz}$ , 2H,

Ar-*H*);  $^{13}\text{C}$  NMR (125 MHz,  $\text{C}_6\text{D}_6$ )  $\delta$  27.9 ( $\text{CH}_3$ ), 54.7 ( $\text{CH}_3$ ), 73.2 ( $\text{CH}_2$ ), 73.4 ( $\text{CH}_2$ ), 82.5 (C), 114.0 (CH), 129.9 (CH), 130.5 (C), 159.8 (C), 160.3 (C), 188.9 (C); HRMS (ESI)  $m/z$   $[\text{M} + \text{Na}]^+$  calcd for  $\text{C}_{16}\text{H}_{20}\text{N}_2\text{O}_5\text{Na}$  343.1264; found 343.1275.

**Methyl (S)-2-Hydroxy-3-(4-methoxybenzyl)oxypropionate (10).** In a flask equipped with a Dean–Stark apparatus,  $\text{Bu}_2\text{SnO}$  (6.22 g, 25.0 mmol) was added to a solution of methyl L-glycerate (**9**, 3.00 g, 25.0 mmol) in benzene (50 mL), and the mixture was refluxed for 1 h. After cooling, the solvent was evaporated in vacuo, and cesium fluoride (5.96 g, 39.2 mmol) was added to the resulting yellow solid. The mixture was cooled to 0 °C, and a solution of 4-methoxybenzyl iodide (8.92 g, 36.0 mmol) in DMF (50 mL) was added. After 8 h of stirring at room temperature, the reaction mixture was poured into an ice-cooled, two-layer mixture of  $\text{Et}_2\text{O}$  (10 mL) and water (150 mL), and the resulting mixture was extracted with AcOEt ( $3 \times 100$  mL). The combined organic extracts were washed with brine (100 mL), and dried over anhydrous  $\text{Na}_2\text{SO}_4$ . Filtration and evaporation in vacuo furnished crude product (15.7 g, yellow oil), which was purified by column chromatography (silica gel 450 g, 5:4 *n*-hexane/AcOEt) to give PMB ether **10** (3.40 g, 57%) as a pale yellow oil.  $R_f$  0.32 (1:1 *n*-hexane/AcOEt);  $[\alpha]_{\text{D}}^{21} +7.6$  ( $c$  5.38, benzene); IR (neat) 3480, 2953, 2864, 1748, 1612, 1514, 1456, 1248, 1126, 1101, 1034, 820  $\text{cm}^{-1}$ ;  $^1\text{H}$  NMR (500 MHz,  $\text{CDCl}_3$ )  $\delta$  3.40 (d,  $J = 6.9$  Hz, 1H,  $\text{CHOH}$ ), 3.68 (d,  $J = 3.5$  Hz, 2H,  $\text{PMBOCH}_2$ ), 3.73 (s, 3H,  $\text{OCH}_3$ ), 3.76 (s, 3H,  $\text{OCH}_3$ ), 4.29 (dt,  $J = 6.9, 3.5$  Hz, 1H,  $\text{CH}_2\text{CHOH}$ ), 4.43 (d,  $J = 11.9$  Hz, 1H, one of  $\text{PMPCH}_2\text{O}$ ), 4.50 (d,  $J = 11.9$  Hz, 1H, one of  $\text{PMPCH}_2\text{O}$ ), 6.84 (d,  $J = 8.8$  Hz, 2H, Ar-*H*), 7.20 (d,  $J = 8.8$  Hz, 2H, Ar-*H*);  $^{13}\text{C}$  NMR (125 MHz,  $\text{CDCl}_3$ )  $\delta$  52.2 ( $\text{CH}_3$ ), 55.0 ( $\text{CH}_3$ ), 70.6 (CH), 70.8 ( $\text{CH}_2$ ), 72.8 ( $\text{CH}_2$ ), 113.5 (CH), 129.1 (CH), 129.5 (C), 159.0 (C), 172.8 (C); HRMS (ESI)  $m/z$   $[\text{M} + \text{Na}]^+$  calcd for  $\text{C}_{12}\text{H}_{16}\text{O}_5\text{Na}$  263.0890; found 263.0890.

**Methyl 3-(4-Methoxybenzyl)oxy-2-oxopropanoate (11).** A mixture of  $\alpha$ -hydroxy ester **10** (2.16 g, 8.97 mmol) and IBX (3.77 g, 13.5 mmol) in AcOEt (45 mL) was refluxed for 6 h. After cooling, the reaction mixture was filtered through a Celite pad, and the filtrate was evaporated in vacuo. Purification of the residue (2.36 g, pale yellow oil) by column chromatography (silica gel 75 g, 3:2 *n*-hexane/AcOEt) afforded  $\alpha$ -ketoester **11** (1.80 g, 84%) as a colorless oil.  $R_f$  0.33 (15:1  $\text{CH}_2\text{Cl}_2/\text{AcOEt}$ ); IR (neat) 2955, 1755, 1732, 1612, 1514, 1250, 1055, 821  $\text{cm}^{-1}$ ;  $^1\text{H}$  NMR (500 MHz,  $\text{CDCl}_3$ )  $\delta$  3.80 (s, 3H,  $\text{OCH}_3$ ), 3.85 (s, 3H,  $\text{OCH}_3$ ), 4.56 (s, 2H,  $\text{OCH}_2$ ), 4.57 (s, 2H,  $\text{OCH}_2$ ), 6.88 (d,  $J = 8.7$  Hz, 2H, Ar-*H*), 7.28 (d,  $J = 8.7$  Hz, 2H, Ar-*H*);  $^{13}\text{C}$  NMR (125 MHz,  $\text{CDCl}_3$ )  $\delta$  52.7 ( $\text{CH}_3$ ), 55.0 ( $\text{CH}_3$ ), 72.2 ( $\text{CH}_2$ ), 72.8 ( $\text{CH}_2$ ), 113.7 (CH), 128.5 (C), 129.5 (CH), 159.3 (C), 160.1 (C), 190.2 (C); HRMS (ESI)  $m/z$   $[\text{M} + \text{Na}]^+$  calcd for  $\text{C}_{12}\text{H}_{14}\text{O}_5\text{Na}$  261.0733; found 261.0743.

**4-tert-Butyl 1-Methyl 3-Diazo-2-[(4-methoxybenzyl)oxymethyl]-2-(trimethylsilyloxy)butanedioate (6a).** LDA [prepared from diisopropylamine (1.00 mL, 7.14 mmol) and BuLi in *n*-hexane (1.45 M, 4.80 mL, 6.96 mmol)] in THF (10 mL) was added to a cooled ( $-78$  °C) mixture of  $\alpha$ -ketoester **11** (1.50 g, 6.30

mmol) and *tert*-butyl diazoacetate (0.93 mL, 6.71 mmol) in THF (50 mL). After 1 h of stirring, the reaction was quenched with saturated aqueous  $\text{NH}_4\text{Cl}$  (20 mL), and the resulting mixture was partitioned between AcOEt (75 mL) and  $\text{H}_2\text{O}$  (20 mL). The aqueous layer was extracted with AcOEt (75 mL), and the combined organic extracts were washed with brine (50 mL) and dried over anhydrous  $\text{Na}_2\text{SO}_4$ . Filtration and evaporation in vacuo furnished the crude product (2.31 g, brown foam), which was chromatographed twice (silica gel 75 g, 3:1 *n*-hexane/AcOEt; silica gel 30 g, 7:1 toluene/AcOEt) to give the coupling product (1.07 g, 45%) as a light yellow oil.  $R_f$  0.34 (3:1 *n*-hexane/AcOEt); IR (neat) 3485, 2978, 2100, 1748, 1694, 1614, 1514, 1323, 1248, 1146, 1034, 821  $\text{cm}^{-1}$ ;  $^1\text{H}$  NMR (500 MHz,  $\text{CDCl}_3$ )  $\delta$  1.45 (s, 9H,  $\text{CO}_2\text{C}(\text{CH}_3)_3$ ), 3.67 (d,  $J = 9.7$  Hz, 1H, one of  $\text{PMBOCH}_2$ ), 3.74 (d,  $J = 9.7$  Hz, 1H, one of  $\text{PMBOCH}_2$ ), 3.802 (s, 3H,  $\text{OCH}_3$ ), 3.803 (s, 3H,  $\text{OCH}_3$ ), 4.22 (br s, 1H, OH), 4.51 (d,  $J = 11.8$  Hz, 1H, one of  $\text{PMPCH}_2\text{O}$ ), 4.55 (d,  $J = 11.8$  Hz, 1H, one of  $\text{PMPCH}_2\text{O}$ ), 6.87 (d,  $J = 8.7$  Hz, 2H, Ar-*H*), 7.21 (d,  $J = 8.7$  Hz, 2H, Ar-*H*);  $^{13}\text{C}$  NMR (125 MHz,  $\text{CDCl}_3$ )  $\delta$  28.1 ( $\text{CH}_3$ ), 53.3 ( $\text{CH}_3$ ), 55.1 ( $\text{CH}_3$ ), 71.7 ( $\text{CH}_2$ ), 73.4 ( $\text{CH}_2$ ), 74.6 (C), 82.4 (C), 113.7 (CH), 129.0 (C), 129.4 (CH), 159.3 (C), 164.8 (C), 171.9 (C); HRMS (ESI)  $m/z$   $[\text{M} + \text{Na}]^+$  calcd for  $\text{C}_{18}\text{H}_{24}\text{N}_2\text{O}_7\text{Na}$  403.1476; found 403.1482.

HMDS (2.20 mL, 10.6 mmol) was added to a mixture of the coupling product (1.36 g, 3.58 mmol) and imidazole (365 mg, 5.36 mmol) in THF (18 mL). After 42 h of stirring, the reaction was quenched with  $\text{H}_2\text{O}$  (50 mL), and the mixture was extracted with AcOEt ( $2 \times 40$  mL). The combined organic extracts were washed with brine (50 mL) and dried over anhydrous  $\text{Na}_2\text{SO}_4$ . Filtration and evaporation in vacuo furnished crude product (1.88 g, light yellow oil), which was purified by column chromatography (silica gel 75 g, 7:1 *n*-hexane/AcOEt) to give cyclization precursor **6a** (1.50 g, 93%) as a pale yellow oil.  $R_f$  0.36 (5:1 *n*-hexane/AcOEt); IR (neat) 2955, 2100, 1748, 1697, 1514, 1321, 1250, 1150, 1036, 845  $\text{cm}^{-1}$ ;  $^1\text{H}$  NMR (500 MHz,  $\text{CDCl}_3$ )  $\delta$  0.14 (s, 9H,  $\text{Si}(\text{CH}_3)_3$ ), 1.43 (s, 9H,  $\text{CO}_2\text{C}(\text{CH}_3)_3$ ), 3.75 (s, 3H,  $\text{CO}_2\text{CH}_3$ ), 3.76 (d,  $J = 10.1$  Hz, 1H, one of  $\text{PMBOCH}_2$ ), 3.804 (s, 3H,  $\text{C}_6\text{H}_4\text{OCH}_3$ ), 3.805 (d,  $J = 10.1$  Hz, 1H, one of  $\text{PMBOCH}_2$ ), 4.51 (s, 2H,  $\text{PMPCH}_2\text{O}$ ), 6.87 (d,  $J = 8.7$  Hz, 2H, Ar-*H*), 7.22 (d,  $J = 8.7$  Hz, 2H, Ar-*H*);  $^{13}\text{C}$  NMR (125 MHz,  $\text{CDCl}_3$ )  $\delta$  1.1 ( $\text{CH}_3$ ), 28.0 ( $\text{CH}_3$ ), 52.4 ( $\text{CH}_3$ ), 54.9 ( $\text{CH}_3$ ), 63.5 (C), 72.9 ( $\text{CH}_2$ ), 73.1 ( $\text{CH}_2$ ), 76.6 (C), 81.6 (C), 113.5 (CH), 129.2 (CH), 129.5 (C), 159.1 (C), 164.0 (C), 170.4 (C); HRMS (ESI)  $m/z$   $[\text{M} + \text{Na}]^+$  calcd for  $\text{C}_{21}\text{H}_{32}\text{N}_2\text{O}_7\text{SiNa}$  475.1871; found 475.1879.

***tert*-Butyl 2-Diazo-4-hydroxy-3-oxobutanoate (12)**. DDQ (40.4 mg, 178  $\mu\text{mol}$ ) was added to an ice-cooled (0  $^\circ\text{C}$ ) solution of PMB ether **5** (38.0 mg, 119  $\mu\text{mol}$ ) in  $\text{CH}_2\text{Cl}_2$  (1.0 mL). After 9 h of stirring, the reaction was quenched with 0.5 M aqueous  $\text{Na}_2\text{S}_2\text{O}_3$  (4 mL), and the resulting mixture was extracted with 2:1 *n*-hexane/AcOEt (10 mL). The organic extract was successively washed with saturated aqueous  $\text{NaHCO}_3$ /1 M aqueous  $\text{Na}_2\text{S}_2\text{O}_3$  (1:1,  $3 \times 4$  mL) and brine ( $2 \times 4$  mL), and dried over anhydrous  $\text{Na}_2\text{SO}_4$ . Filtration and evaporation in vacuo furnished the crude product (69.5 mg, yellow oil), which was purified by flash column chromatography (silica gel 2 g, 10:1 *n*-hexane/AcOEt) to give alcohol **12** (5.4 mg, 23%)

as a yellow oil.  $R_f$  0.47 (3:1 *n*-hexane/AcOEt); IR (neat) 2978, 2924, 2851, 2141, 1713, 1653, 1369, 1317, 1136, 991  $\text{cm}^{-1}$ ;  $^1\text{H}$  NMR (500 MHz,  $\text{CDCl}_3$ )  $\delta$  1.54 (s, 9H,  $\text{CO}_2\text{C}(\text{CH}_3)_3$ ), 3.46 (t,  $J = 5.0$  Hz, 1H, OH), 4.59 (d,  $J = 5.0$  Hz, 2H,  $\text{OCH}_2$ );  $^{13}\text{C}$  NMR (125 MHz,  $\text{CDCl}_3$ )  $\delta$  28.2 ( $\text{CH}_3$ ), 66.9 ( $\text{CH}_2$ ), 84.1 (C), 160.0 (C), 192.0 (C); HRMS (ESI)  $m/z$   $[\text{M} + \text{Na}]^+$  calcd for  $\text{C}_8\text{H}_{12}\text{N}_2\text{O}_4\text{Na}$  223.0689; found 223.0686.

**Typical Procedure for Cyclization: 4-*tert*-Butyl 3-Methyl 5-(4-Methoxyphenyl)-3-(trimethylsilyl)oxy-2,3-dihydrofuran-3,4-dicarboxylate (14a).** A solution of  $\alpha$ -diazo ester **6a** (900 mg, 1.99 mmol) in  $\text{CH}_2\text{Cl}_2$  (20 mL) was added to a flask containing DDQ (542 mg, 2.39 mmol) at 0 °C. After 3 h of stirring at 20 °C, the reaction was quenched with half-saturated aqueous  $\text{NaHCO}_3$  (20 mL), and the resulting mixture was extracted with 1:1 *n*-hexane/AcOEt ( $2 \times 30$  mL). The combined organic extracts were washed with brine (30 mL), and dried over anhydrous  $\text{Na}_2\text{SO}_4$ . Filtration and evaporation in vacuo furnished the crude product (1.08 g, brown oil), which was chromatographed twice (silica gel 30 g, 20:1 toluene/AcOEt; silica gel 15 g, 6:1 *n*-hexane/AcOEt) to give dihydrofuran **14a** (667 mg, 79%) as a white solid.  $R_f$  0.43 (5:1 *n*-hexane/AcOEt); mp 93–94 °C (colorless plates from 20:1 *n*-hexane/AcOEt); IR (KBr) 2986, 2963, 1763, 1684, 1618, 1510, 1373, 1260, 1128, 1101, 837  $\text{cm}^{-1}$ ;  $^1\text{H}$  NMR (500 MHz,  $\text{CDCl}_3$ )  $\delta$  0.17 (s, 9H,  $\text{Si}(\text{CH}_3)_3$ ), 1.42 (s, 9H,  $\text{CO}_2\text{C}(\text{CH}_3)_3$ ), 3.77 (s, 3H,  $\text{CO}_2\text{CH}_3$ ), 3.85 (s, 3H,  $\text{C}_6\text{H}_4\text{OCH}_3$ ), 4.41 (d,  $J = 10.4$  Hz, 1H, one of  $\text{OCH}_2$ ), 4.64 (d,  $J = 10.4$  Hz, 1H, one of  $\text{OCH}_2$ ), 6.93 (d,  $J = 8.8$  Hz, 2H, Ar-*H*), 7.84 (d,  $J = 8.8$  Hz, 2H, Ar-*H*);  $^{13}\text{C}$  NMR (125 MHz,  $\text{CDCl}_3$ )  $\delta$  1.6 ( $\text{CH}_3$ ), 28.1 ( $\text{CH}_3$ ), 52.6 ( $\text{CH}_3$ ), 55.3 ( $\text{CH}_3$ ), 80.5 (C), 81.6 ( $\text{CH}_2$ ), 86.4 (C), 108.4 (C), 113.1 (CH), 121.3 (C), 131.6 (CH), 161.8 (C), 163.1 (C), 168.5 (C), 172.6 (C); HRMS (ESI)  $m/z$   $[\text{M} + \text{Na}]^+$  calcd for  $\text{C}_{21}\text{H}_{30}\text{O}_7\text{SiNa}$  445.1653; found 445.1660.

**4-Ethyl 3-Methyl 5-(4-Methoxyphenyl)-3-(trimethylsilyl)oxy-2,3-dihydrofuran-3,4-dicarboxylate (14b).** The reaction was performed according to the typical procedure (1.2 mL  $\text{CH}_2\text{Cl}_2$ , 20 °C, 5 h) employing  $\alpha$ -diazo ester **6b** (51.1 mg, 120  $\mu\text{mol}$ ) and DDQ (32.8 mg, 144  $\mu\text{mol}$ ). Dihydrofuran **14b** (33.9 mg, 72%) was obtained as a white solid from the crude product (46.9 mg, orange oil) after column chromatography (silica gel 5 g, 7:1 *n*-hexane/AcOEt).  $R_f$  0.42 (7:1 *n*-hexane/AcOEt); mp 116–117 °C (colorless needles from *n*-hexane/AcOEt); IR (KBr) 2970, 1767, 1699, 1611, 1510, 1329, 1258, 1186, 1132, 1106, 1084  $\text{cm}^{-1}$ ;  $^1\text{H}$  NMR (500 MHz,  $\text{CDCl}_3$ )  $\delta$  0.15 (s, 9H,  $\text{Si}(\text{CH}_3)_3$ ), 1.21 (t,  $J = 7.1$  Hz, 3H,  $\text{CO}_2\text{CH}_2\text{CH}_3$ ), 3.76 (s, 3H,  $\text{CO}_2\text{CH}_3$ ), 3.85 (s, 3H,  $\text{C}_6\text{H}_4\text{OCH}_3$ ), 4.05 (dq,  $J = 10.8, 7.1$  Hz, 1H, one of  $\text{CO}_2\text{CH}_2\text{CH}_3$ ), 4.22 (dq,  $J = 10.8, 7.1$  Hz, 1H, one of  $\text{CO}_2\text{CH}_2\text{CH}_3$ ), 4.44 (d,  $J = 10.4$  Hz, 1H, one of  $\text{OCH}_2$ ), 4.68 (d,  $J = 10.4$  Hz, 1H, one of  $\text{OCH}_2$ ), 6.93 (d,  $J = 9.0$  Hz, 2H, Ar-*H*), 7.87 (d,  $J = 9.0$  Hz, 2H, Ar-*H*);  $^{13}\text{C}$  NMR (125 MHz,  $\text{CDCl}_3$ )  $\delta$  1.5 ( $\text{CH}_3$ ), 14.0 ( $\text{CH}_3$ ), 52.6 ( $\text{CH}_3$ ), 55.2 ( $\text{CH}_3$ ), 59.7 ( $\text{CH}_2$ ), 82.1 ( $\text{CH}_2$ ), 86.1 (C), 106.9 (C), 113.0 (CH), 121.0 (C), 131.7 (CH), 162.0 (C), 163.7 (C), 169.5 (C), 172.6 (C); HRMS (ESI)  $m/z$   $[\text{M} + \text{Na}]^+$  calcd for  $\text{C}_{19}\text{H}_{26}\text{O}_7\text{SiNa}$  417.1340; found 417.1340.

**4-*tert*-Butyl 3-Methyl 5-(3,4-Dimethoxyphenyl)-3-(trimethylsilyl)oxy-2,3-dihydrofuran-3,4-dicarboxylate (14c).** The reaction was performed according to the typical procedure (1.0 mL  $\text{CH}_2\text{Cl}_2$ , 20 °C,

45 min) employing  $\alpha$ -diazo ester **6c** (50.0 mg, 104  $\mu$ mol) and DDQ (28.2 mg, 124  $\mu$ mol). Dihydrofuran **14c** (30.8 mg, 65%) was obtained as a colorless oil from the crude product (48.1 mg, brown oil) after column chromatography (silica gel 5 g, 5:1 *n*-hexane/AcOEt).  $R_f$  0.47 (10:3 *n*-hexane/AcOEt); IR (neat) 2955, 1761, 1701, 1603, 1516, 1458, 1368, 1269, 1252, 1161, 1136, 1101, 1080, 1024, 997, 843  $\text{cm}^{-1}$ ;  $^1\text{H}$  NMR (500 MHz,  $\text{CDCl}_3$ )  $\delta$  0.17 (s, 9H,  $\text{Si}(\text{CH}_3)_3$ ), 1.41 (s, 9H,  $\text{CO}_2\text{C}(\text{CH}_3)_3$ ), 3.77 (s, 3H,  $\text{CO}_2\text{CH}_3$ ), 3.91 (s, 3H,  $\text{OCH}_3$ ), 3.92 (s, 3H,  $\text{OCH}_3$ ), 4.41 (d,  $J = 10.4$  Hz, 1H, one of  $\text{OCH}_2$ ), 4.63 (d,  $J = 10.4$  Hz, 1H, one of  $\text{OCH}_2$ ), 6.90 (d,  $J = 8.5$  Hz, 1H, Ar-*H*), 7.43 (d,  $J = 2.1$  Hz, 1H, Ar-*H*), 7.56 (dd,  $J = 2.1, 8.5$  Hz, 1H, Ar-*H*);  $^{13}\text{C}$  NMR (125 MHz,  $\text{CDCl}_3$ )  $\delta$  1.7 ( $\text{CH}_3$ ), 28.1 ( $\text{CH}_3$ ), 52.6 ( $\text{CH}_3$ ), 55.9 ( $2 \times \text{CH}_3$ ), 80.5 (C), 81.5 ( $\text{CH}_2$ ), 86.5 (C), 108.7 (C), 110.0 (CH), 112.6 (CH), 121.4 (C), 123.8 (CH), 148.0 (C), 151.4 (C), 163.2 (C), 168.3 (C), 172.6 (C); HRMS (ESI)  $m/z$   $[\text{M} + \text{Na}]^+$  calcd for  $\text{C}_{22}\text{H}_{32}\text{O}_8\text{SiNa}$  475.1759; found 475.1768.

**4-tert-Butyl 3-Methyl 5-(3,4,5-Trimethoxyphenyl)-3-(trimethylsilyloxy)-2,3-dihydrofuran-3,4-dicarboxylate (14d)**. The reaction was performed according to the typical procedure (1.0 mL  $\text{CH}_2\text{Cl}_2$ , 20  $^\circ\text{C}$ , 16 h) employing  $\alpha$ -diazo ester **6d** (50.0 mg, 97.5  $\mu$ mol) and DDQ (26.6 mg, 117  $\mu$ mol). Dihydrofuran **14d** (30.8 mg, 65%) was obtained as a creamy, pale yellow solid from the crude product (45.8 mg, brown oil) after column chromatography (silica gel 4 g, 3:1 *n*-hexane/AcOEt).  $R_f$  0.44 (3:1 *n*-hexane/AcOEt); mp 99–100  $^\circ\text{C}$  (colorless plates from 5:1 *n*-hexane/AcOEt); IR (KBr) 2972, 1724, 1701, 1580, 1504, 1456, 1420, 1371, 1302, 1250, 1157, 1125, 1107, 1084, 972, 843  $\text{cm}^{-1}$ ;  $^1\text{H}$  NMR (500 MHz,  $\text{CDCl}_3$ )  $\delta$  0.18 (s, 9H,  $\text{Si}(\text{CH}_3)_3$ ), 1.41 (s, 9H,  $\text{CO}_2\text{C}(\text{CH}_3)_3$ ), 3.78 (s, 3H,  $\text{CO}_2\text{CH}_3$ ), 3.88 (s, 9H,  $3 \times \text{OCH}_3$ ), 4.41 (d,  $J = 10.4$  Hz, 1H, one of  $\text{OCH}_2$ ), 4.64 (d,  $J = 10.4$  Hz, 1H, one of  $\text{OCH}_2$ ), 7.16 (s, 2H, Ar-*H*);  $^{13}\text{C}$  NMR (125 MHz,  $\text{CDCl}_3$ )  $\delta$  1.7 ( $\text{CH}_3$ ), 28.1 ( $\text{CH}_3$ ), 52.6 ( $\text{CH}_3$ ), 56.1 ( $\text{CH}_3$ ), 60.8 ( $\text{CH}_3$ ), 80.6 (C), 81.6 ( $\text{CH}_2$ ), 86.5 (C), 107.3 (CH), 109.5 (C), 124.1 (C), 140.5 (C), 152.4 (C), 163.0 (C), 167.9 (C), 172.5 (C); HRMS (ESI)  $m/z$   $[\text{M} + \text{Na}]^+$  calcd for  $\text{C}_{23}\text{H}_{34}\text{O}_9\text{SiNa}$  505.1864; found 505.1876.

**4-tert-Butyl 3-Methyl 5-(2-Methoxyphenyl)-3-(trimethylsilyloxy)-2,3-dihydrofuran-3,4-dicarboxylate (14e)**. The reaction was performed according to the typical procedure (1.1 mL  $\text{CH}_2\text{Cl}_2$ , 20  $^\circ\text{C}$ , 25 h) employing  $\alpha$ -diazo ester **6e** (50.0 mg, 110  $\mu$ mol) and DDQ (30.1 mg, 133  $\mu$ mol). Dihydrofuran **14e** (18.8 mg, 40%) was obtained as a colorless oil from the crude product (46.0 mg, brown oil) after column chromatography (silica gel 5 g, 7:1 *n*-hexane/AcOEt).  $R_f$  0.30 (5:1 *n*-hexane/AcOEt); IR (neat) 2970, 1761, 1703, 1624, 1589, 1499, 1368, 1339, 1248, 1165, 1123, 843  $\text{cm}^{-1}$ ;  $^1\text{H}$  NMR (500 MHz,  $\text{CDCl}_3$ )  $\delta$  0.22 (s, 9H,  $\text{Si}(\text{CH}_3)_3$ ), 1.26 (s, 9H,  $\text{CO}_2\text{C}(\text{CH}_3)_3$ ), 3.80 (s, 3H,  $\text{OCH}_3$ ), 3.82 (s, 3H,  $\text{OCH}_3$ ), 4.45 (d,  $J = 10.5$  Hz, 1H, one of  $\text{OCH}_2$ ), 4.73 (d,  $J = 10.5$  Hz, 1H, one of  $\text{OCH}_2$ ), 6.93 (d,  $J = 8.2$  Hz, 1H, Ar-*H*), 6.98 (t,  $J = 7.6$  Hz, 1H, Ar-*H*), 7.38 (dd,  $J = 1.5, 7.6$  Hz, 1H, Ar-*H*), 7.39 (ddd,  $J = 1.5, 7.6, 8.2$  Hz, 1H, Ar-*H*);  $^{13}\text{C}$  NMR (125 MHz,  $\text{CDCl}_3$ )  $\delta$  1.4 ( $\text{CH}_3$ ), 27.9 ( $\text{CH}_3$ ), 52.8 ( $\text{CH}_3$ ), 55.3 ( $\text{CH}_3$ ), 79.9 (C), 82.9 ( $\text{CH}_2$ ), 85.4 (C), 111.0 (CH), 112.2 (C), 119.8 (C), 120.0 (CH), 130.4 (CH), 131.6 (CH), 157.4 (C), 162.5 (C), 167.0 (C),

172.8 (C); HRMS (ESI)  $m/z$   $[M + Na]^+$  calcd for  $C_{21}H_{30}O_7SiNa$  445.1653; found 445.1649.

**4-tert-Butyl 3-Methyl 5-(3-Methoxyphenyl)-3-(trimethylsilyloxy)-2,3-dihydrofuran-3,4-dicarboxylate (14f).** The reaction was performed according to the typical procedure (1.1 mL  $CH_2Cl_2$ , 40 °C, 18 h) employing  $\alpha$ -diazo ester **6f** (50.0 mg, 110  $\mu$ mol) and DDQ (30.1 mg, 133  $\mu$ mol). Dihydrofuran **14f** (13.8 mg, 30%) was obtained as a white solid from the crude product (27.4 mg, deep green oil) after flash column chromatography (silica gel 5 g, 7:1 *n*-hexane/AcOEt).  $R_f$  0.43 (5:1 *n*-hexane/AcOEt); mp 85–86 °C (colorless plates from 20:1 *n*-hexane/AcOEt); IR (KBr) 2967, 1761, 1697, 1601, 1576, 1456, 1252, 1227, 1136, 1105, 1078  $cm^{-1}$ ;  $^1H$  NMR (500 MHz,  $CDCl_3$ )  $\delta$  0.19 (s, 9H,  $Si(CH_3)_3$ ), 1.39 (s, 9H,  $CO_2C(CH_3)_3$ ), 3.79 (s, 3H,  $CO_2CH_3$ ), 3.83 (s, 3H,  $OCH_3$ ), 4.43 (d,  $J = 10.5$  Hz, 1H, one of  $OCH_2$ ), 4.67 (d,  $J = 10.5$  Hz, 1H, one of  $OCH_2$ ), 7.01 (d,  $J = 8.0$  Hz, 1H, Ar-*H*), 7.31 (s, 1H, Ar-*H*), 7.33 (dd,  $J = 7.8, 8.0$  Hz, 1H, Ar-*H*), 7.39 (d,  $J = 7.8$  Hz, 1H, Ar-*H*);  $^{13}C$  NMR (125 MHz,  $CDCl_3$ )  $\delta$  1.7 ( $CH_3$ ), 28.1 ( $CH_3$ ), 52.7 ( $CH_3$ ), 55.3 ( $CH_3$ ), 80.7 (C), 81.9 ( $CH_2$ ), 86.3 (C), 110.1 (C), 114.9 (CH), 116.9 (CH), 122.2 (CH), 128.8 (CH), 130.4 (C), 158.8 (C), 162.8 (C), 168.2 (C), 172.5 (C); HRMS (ESI)  $m/z$   $[M + Na]^+$  calcd for  $C_{21}H_{30}O_7SiNa$  445.1653; found 445.1639.

**4-tert-Butyl 3-Methyl 5-Phenyl-3-(trimethylsilyloxy)-2,3-dihydrofuran-3,4-dicarboxylate (14g).** The reaction was performed according to the typical procedure (1.2 mL chlorobenzene, 80 °C, 3 h) employing  $\alpha$ -diazo ester **6g** (50.0 mg, 118  $\mu$ mol) and DDQ (32.2 mg, 142  $\mu$ mol). Dihydrofuran **14g** (10.3 mg, 22%) was obtained as a white solid from the crude product (55.0 mg, brown oil) after column chromatography (silica gel 4 g, 7:1 *n*-hexane/AcOEt).  $R_f$  0.43 (5:1 *n*-hexane/AcOEt); mp 95–96 °C (colorless needles from 20:1 *n*-hexane/AcOEt); IR (KBr) 2978, 1761, 1703, 1622, 1225, 1167, 1140, 1103, 1070, 845  $cm^{-1}$ ;  $^1H$  NMR (500 MHz,  $CDCl_3$ )  $\delta$  0.19 (s, 9H,  $Si(CH_3)_3$ ), 1.39 (s, 9H,  $CO_2C(CH_3)_3$ ), 3.79 (s, 3H,  $CO_2CH_3$ ), 4.44 (d,  $J = 10.5$  Hz, 1H, one of  $OCH_2$ ), 4.68 (d,  $J = 10.5$  Hz, 1H, one of  $OCH_2$ ), 7.40 (t,  $J = 7.3$  Hz, 2H, Ar-*H*), 7.46 (t,  $J = 7.3$  Hz, 1H, Ar-*H*), 7.79 (d,  $J = 7.3$  Hz, 2H, Ar-*H*);  $^{13}C$  NMR (125 MHz,  $CDCl_3$ )  $\delta$  1.7 ( $CH_3$ ), 28.1 ( $CH_3$ ), 52.7 ( $CH_3$ ), 80.8 (C), 82.0 ( $CH_2$ ), 86.3 (C), 109.9 (C), 127.7 (CH), 129.3 (C), 129.7 (CH), 131.0 (CH), 162.8 (C), 168.6 (C), 172.6 (C); HRMS (ESI)  $m/z$   $[M + Na]^+$  calcd for  $C_{20}H_{28}O_6SiNa$  415.1547; found 415.1547.

**4-tert-Butyl 3-Methyl 5-(3,4-Methylenedioxyphenyl)-3-(trimethylsilyloxy)-2,3-dihydrofuran-3,4-dicarboxylate (14h).** The reaction was performed according to the typical procedure (1.1 mL  $CH_2Cl_2$ , 20 °C, 8 h) employing  $\alpha$ -diazo ester **6h** (50.0 mg, 104  $\mu$ mol) and DDQ (29.2 mg, 129  $\mu$ mol). Dihydrofuran **14h** (32.5 mg, 70%) was obtained as a white solid from the crude product (56.4 mg, pale brown oil) after column chromatography (silica gel 5 g, 4:1 *n*-hexane/AcOEt).  $R_f$  0.50 (3:1 *n*-hexane/AcOEt); mp 117–118 °C (colorless plates from 20:1 *n*-hexane/AcOEt); IR (KBr) 2967, 1759, 1695, 1593, 1500, 1449, 1331, 1254, 1130, 1080, 1040, 843  $cm^{-1}$ ;  $^1H$  NMR (500 MHz,  $CDCl_3$ )  $\delta$  0.17 (s, 9H,  $Si(CH_3)_3$ ), 1.41 (s, 9H,  $CO_2C(CH_3)_3$ ), 3.77 (s, 3H,  $CO_2CH_3$ ), 4.39 (d,  $J = 10.4$  Hz, 1H, one of  $OCH_2$ ), 4.62 (d,  $J = 10.4$  Hz,

1H, one of OCH<sub>2</sub>), 6.01 (s, 2H, OCH<sub>2</sub>O), 6.85 (d, *J* = 8.2 Hz, 1H, Ar-*H*), 7.34 (d, *J* = 1.5 Hz, 1H, Ar-*H*), 7.43 (dd, *J* = 1.5, 8.2 Hz, 1H, Ar-*H*); <sup>13</sup>C NMR (125 MHz, CDCl<sub>3</sub>) δ 1.7 (CH<sub>3</sub>), 28.1 (CH<sub>3</sub>), 52.6 (CH<sub>3</sub>), 80.7 (C), 81.6 (CH<sub>2</sub>), 86.4 (C), 101.5 (CH<sub>2</sub>), 107.7 (CH), 108.9 (C), 110.2 (CH), 122.8 (C), 125.0 (CH), 147.0 (C), 149.9 (C), 163.0 (C), 168.0 (C), 172.5 (C); HRMS (ESI) *m/z* [M + Na]<sup>+</sup> calcd for C<sub>21</sub>H<sub>28</sub>O<sub>8</sub>SiNa 459.1446; found 459.1437.

**4-*tert*-Butyl 3-Methyl 5-(Naphthalen-2-yl)-3-(trimethylsilyl)oxy-2,3-dihydrofuran-3,4-dicarboxylate (14i).** The reaction was performed according to the typical procedure (1.1 mL CH<sub>2</sub>Cl<sub>2</sub>, 20 °C, 3 h) employing α-diazo ester **6i** (50.0 mg, 106 μmol) and DDQ (28.8 mg, 127 μmol). Dihydrofuran **14i** (24.7 mg, 53%) was obtained as a colorless oil from the crude product (49.5 mg, brown oil) after column chromatography (silica gel 5 g, 10:1 *n*-hexane/AcOEt). *R<sub>f</sub>* 0.40 (5:1 *n*-hexane/AcOEt); mp 78–79 °C (colorless needles from *n*-hexane); IR (KBr) 2978, 2955, 1761, 1701, 1618, 1369, 1252, 1155, 1140, 1128, 1096, 1080, 997, 843 cm<sup>-1</sup>; <sup>1</sup>H NMR (500 MHz, CDCl<sub>3</sub>) δ 0.22 (s, 9H, Si(CH<sub>3</sub>)<sub>3</sub>), 1.40 (s, 9H, CO<sub>2</sub>C(CH<sub>3</sub>)<sub>3</sub>), 3.81 (s, 3H, CO<sub>2</sub>CH<sub>3</sub>), 4.50 (d, *J* = 10.5 Hz, 1H, one of OCH<sub>2</sub>), 4.74 (d, *J* = 10.5 Hz, 1H, one of OCH<sub>2</sub>), 7.51 (ddd, *J* = 1.4, 6.8, 8.2 Hz, 1H, Ar-*H*), 7.55 (ddd, *J* = 1.3, 6.8, 8.2 Hz, 1H, Ar-*H*), 7.85–7.87 (m, 3H, Ar-*H*), 7.91 (d, *J* = 7.6 Hz, 1H, Ar-*H*), 8.34 (s, 1H, Ar-*H*); <sup>13</sup>C NMR (125 MHz, CDCl<sub>3</sub>) δ 1.7 (CH<sub>3</sub>), 28.1 (CH<sub>3</sub>), 52.7 (CH<sub>3</sub>), 80.8 (C), 82.0 (CH<sub>2</sub>), 86.4 (C), 110.2 (C), 126.2 (CH), 126.4 (CH), 126.7 (C), 127.2 (CH), 127.5 (CH), 127.7 (CH), 128.9 (CH), 130.4 (CH), 132.3 (C), 134.4 (C), 162.9 (C), 168.4 (C), 172.5 (C); HRMS (ESI) *m/z* [M + Na]<sup>+</sup> calcd for C<sub>24</sub>H<sub>30</sub>O<sub>6</sub>SiNa 465.1704; found 465.1703.

**4-*tert*-Butyl 3-Methyl 5-(4-Acetamidophenyl)-3-(trimethylsilyl)oxy-2,3-dihydrofuran-3,4-dicarboxylate (14j).** The reaction was performed according to the typical procedure (2.5 mL CH<sub>2</sub>Cl<sub>2</sub>, 20 °C, 8 h) employing α-diazo ester **6j** (118 mg, 246 μmol) and DDQ (68.0 mg, 295 μmol). Dihydrofuran **14j** (64.6 mg, 58%) was obtained as a creamy, pale yellow solid from the crude product (123 mg, brown oil) after column chromatography (twice, silica gel 10 g, 3:5 *n*-hexane/AcOEt; Bio-Beads S-X3, toluene). *R<sub>f</sub>* 0.33 (1:2 *n*-hexane/AcOEt); mp 96–98 °C (colorless needles from 2:1 *n*-hexane/CHCl<sub>3</sub>); IR (KBr) 3431, 3331, 2978, 2955, 1775, 1713, 1668, 1611, 1514, 1369, 1319, 1258, 1136, 1105, 845 cm<sup>-1</sup>; <sup>1</sup>H NMR (500 MHz, CDCl<sub>3</sub>) δ 0.16 (s, 9H, Si(CH<sub>3</sub>)<sub>3</sub>), 1.41 (s, 9H, CO<sub>2</sub>C(CH<sub>3</sub>)<sub>3</sub>), 2.10 (s, 3H, NHCOCH<sub>3</sub>), 3.76 (s, 3H, CO<sub>2</sub>CH<sub>3</sub>), 4.41 (d, *J* = 10.5 Hz, 1H, one of OCH<sub>2</sub>), 4.64 (d, *J* = 10.5 Hz, 1H, one of OCH<sub>2</sub>), 7.55 (d, *J* = 8.5 Hz, 2H, Ar-*H*), 7.73 (d, *J* = 8.5 Hz, 2H, Ar-*H*), 8.22 (br s, 1H, NHAc); <sup>13</sup>C NMR (125 MHz, CDCl<sub>3</sub>) δ 1.6 (CH<sub>3</sub>), 24.4 (CH<sub>3</sub>), 28.1 (CH<sub>3</sub>), 52.7 (CH<sub>3</sub>), 80.9 (C), 81.8 (CH<sub>2</sub>), 86.2 (C), 109.0 (C), 118.4 (CH), 124.0 (C), 130.6 (CH), 140.9 (C), 163.4 (C), 168.5 (C), 168.9 (C), 172.6 (C); HRMS (ESI) *m/z* [M + Na]<sup>+</sup> calcd for C<sub>22</sub>H<sub>31</sub>NO<sub>7</sub>SiNa 472.1762; found 472.1745.

**4-*tert*-Butyl 3-Methyl (2*S*\*,3*S*\*)-5-(4-Methoxyphenyl)-2-methyl-3-(trimethylsilyl)oxy-2,3-dihydrofuran-3,4-dicarboxylate (14l).** The reaction was performed according to the typical procedure (1.1 mL

CH<sub>2</sub>Cl<sub>2</sub>, 20 °C, 1.5 h) employing  $\alpha$ -diazo ester **6l** (50.0 mg, 107  $\mu$ mol) and DDQ (29.2 mg, 129  $\mu$ mol). Dihydrofuran **14l** (31.5 mg, 67%) was obtained as a colorless oil from the crude product (50.0 mg, brown oil) after column chromatography (silica gel 5 g, 7:1 *n*-hexane/AcOEt). *R<sub>f</sub>* 0.47 (5:1 *n*-hexane/AcOEt); IR (KBr) 2978, 2957, 1761, 1684, 1609, 1510, 1368, 1256, 1101, 1036, 843 cm<sup>-1</sup>; <sup>1</sup>H NMR (500 MHz, CDCl<sub>3</sub>)  $\delta$  0.18 (s, 9H, Si(CH<sub>3</sub>)<sub>3</sub>), 1.38 (d, *J* = 6.6 Hz, 3H, OCHCH<sub>3</sub>), 1.41 (s, 9H, CO<sub>2</sub>C(CH<sub>3</sub>)<sub>3</sub>), 3.76 (s, 3H, OCH<sub>3</sub>), 3.84 (s, 3H, OCH<sub>3</sub>), 4.83 (q, *J* = 6.6 Hz, 1H, OCHCH<sub>3</sub>), 6.91 (d, *J* = 9.0 Hz, 2H, Ar-*H*), 7.77 (d, *J* = 9.0 Hz, 2H, Ar-*H*); <sup>13</sup>C NMR (125 MHz, CDCl<sub>3</sub>)  $\delta$  2.0 (CH<sub>3</sub>), 13.0 (CH<sub>3</sub>), 28.2 (CH<sub>3</sub>), 52.5 (CH<sub>3</sub>), 55.3 (CH<sub>3</sub>), 80.6 (C), 86.4 (CH), 86.8 (C), 109.1 (C), 113.0 (CH), 121.7 (C), 131.8 (CH), 161.8 (C), 163.4 (C), 169.1 (C), 172.5 (C); HRMS (ESI) *m/z* [M + Na]<sup>+</sup> calcd for C<sub>22</sub>H<sub>32</sub>O<sub>7</sub>SiNa 459.1810; found 459.1825.

**4-tert-Butyl 3-Methyl 5-(4-Methoxyphenyl)-2,2-dimethyl-3-(trimethylsilyloxy)-2,3-dihydrofuran-3,4-dicarboxylate (14m)**. The reaction was performed according to the typical procedure (5 mL CH<sub>2</sub>Cl<sub>2</sub>, 20 °C, 30 min) employing  $\alpha$ -diazo ester **6m** (218 mg, 454  $\mu$ mol) and DDQ (124 mg, 546  $\mu$ mol). Dihydrofuran **14m** (174 mg, 85%) was obtained as a colorless solid from the crude product (222 mg, light brown oil) after column chromatography (silica gel 10 g, 7:1 *n*-hexane/AcOEt). *R<sub>f</sub>* 0.30 (7:1 *n*-hexane/AcOEt); mp 71–72 °C (colorless plates from *n*-hexane); IR (KBr) 2986, 2951, 1744, 1686, 1620, 1514, 1368, 1258, 1180, 1144, 1125, 1096, 1045, 897, 845 cm<sup>-1</sup>; <sup>1</sup>H NMR (500 MHz, CDCl<sub>3</sub>)  $\delta$  0.18 (s, 9H, Si(CH<sub>3</sub>)<sub>3</sub>), 1.34 (s, 3H, CCH<sub>3</sub>), 1.40 (s, 9H, CO<sub>2</sub>C(CH<sub>3</sub>)<sub>3</sub>), 1.46 (s, 3H, CCH<sub>3</sub>), 3.73 (s, 3H, CO<sub>2</sub>CH<sub>3</sub>), 3.84 (s, 3H, C<sub>6</sub>H<sub>4</sub>OCH<sub>3</sub>), 6.90 (d, *J* = 8.9 Hz, 2H, Ar-*H*), 7.66 (d, *J* = 8.9 Hz, 2H, Ar-*H*); <sup>13</sup>C NMR (125 MHz, CDCl<sub>3</sub>)  $\delta$  2.0 (CH<sub>3</sub>), 22.0 (CH<sub>3</sub>), 24.7 (CH<sub>3</sub>), 28.2 (CH<sub>3</sub>), 51.9 (CH<sub>3</sub>), 55.3 (CH<sub>3</sub>), 80.2 (C), 89.9 (C), 90.9 (C), 107.8 (C), 113.0 (CH), 122.5 (C), 131.2 (CH), 161.4 (C), 164.2 (C), 166.8 (C), 171.2 (C); HRMS (ESI) *m/z* [M + Na]<sup>+</sup> calcd for C<sub>23</sub>H<sub>34</sub>O<sub>7</sub>SiNa 473.1966; found 473.1972.

**3-tert-Butyl 4-Methyl 2-Phenyl-4-(trimethylsilyloxy)-1-oxaspiro[4.4]non-2-ene-3,4-dicarboxylate (14n)**. The reaction was performed according to the typical procedure (0.8 mL CH<sub>2</sub>Cl<sub>2</sub>, 20 °C, 9 h) employing  $\alpha$ -diazo ester **6n** (40.7 mg, 85.4  $\mu$ mol) and DDQ (23.3 mg, 103  $\mu$ mol). Dihydrofuran **14n** (22.4 mg, 59%) was obtained as a colorless oil from the crude product (40.3 mg, brown oil) after flash column chromatography (silica gel 5 g, 10:1 *n*-hexane/AcOEt) followed by preparative thin-layer chromatography (200 mm  $\times$  200 mm  $\times$  0.25 mm preparative silica gel plate, 5:1 *n*-hexane/AcOEt). *R<sub>f</sub>* 0.40 (5:1 *n*-hexane/AcOEt); mp 98–99 °C (colorless needles from *n*-hexane); IR (KBr) 2982, 2957, 1751, 1690, 1636, 1362, 1260, 1246, 1140, 1125, 1099, 843 cm<sup>-1</sup>; <sup>1</sup>H NMR (500 MHz, CDCl<sub>3</sub>)  $\delta$  0.18 (s, 9H, Si(CH<sub>3</sub>)<sub>3</sub>), 1.37 (s, 9H, CO<sub>2</sub>C(CH<sub>3</sub>)<sub>3</sub>), 1.68–1.99 (m, 7H, seven of (CH<sub>2</sub>)<sub>4</sub>), 2.15 (m, 1H, one of (CH<sub>2</sub>)<sub>4</sub>), 3.73 (s, 3H, CO<sub>2</sub>CH<sub>3</sub>), 7.38–7.45 (m, 3H, Ar-*H*), 7.66 (d, *J* = 6.7 Hz, 2H, Ar-*H*); <sup>13</sup>C NMR (125 MHz, CDCl<sub>3</sub>)  $\delta$  2.1 (CH<sub>3</sub>), 22.4 (CH<sub>2</sub>), 24.2 (CH<sub>2</sub>), 28.1 (CH<sub>3</sub>), 32.4 (CH<sub>2</sub>), 37.2 (CH<sub>2</sub>), 51.9 (CH<sub>3</sub>), 80.3 (C), 88.7 (C), 103.2 (C), 109.6 (C), 127.6 (CH), 129.5 (CH), 130.3 (C), 130.5 (CH), 163.6 (C), 167.2 (C),

171.5 (C); HRMS (ESI)  $m/z$   $[M + Na]^+$  calcd for  $C_{24}H_{34}O_6SiNa$  469.2017; found 469.2004.

**4-tert-Butyl 3-Methyl 5-(4-Methoxyphenyl)-3-(trimethylsilyloxy)-2,3-dihydrothiophene-3,4-dicarboxylate (14o).** The reaction was performed according to the typical procedure (1.0 mL  $CH_2Cl_2$ , 20 °C, 2 h) employing  $\alpha$ -diazo ester **6o** (48.6 mg, 104  $\mu$ mol) and DDQ (28.3 mg, 125  $\mu$ mol). Dihydrothiophene **14o** (17.8 mg, 39%) was obtained as a white solid from the crude product (48.4 mg, brown oil) after column chromatography (twice, silica gel 5 g, 7:1 *n*-hexane/AcOEt; Bio-Beads S-X3, toluene).  $R_f$  0.44 (5:1 *n*-hexane/AcOEt); mp 114–115 °C (colorless plates from 20:1 *n*-hexane/AcOEt); IR (KBr) 2976, 2953, 1759, 1609, 1506, 1368, 1325, 1294, 1250, 1138, 1101, 843  $cm^{-1}$ ;  $^1H$  NMR (500 MHz,  $CDCl_3$ )  $\delta$  0.23 (s, 9H, Si( $CH_3$ )<sub>3</sub>), 1.28 (s, 9H,  $CO_2C(CH_3)_3$ ), 3.13 (d,  $J = 12.5$  Hz, 1H, one of SCH<sub>2</sub>), 3.76 (d,  $J = 12.5$  Hz, 1H, one of SCH<sub>2</sub>), 3.77 (s, 3H, OCH<sub>3</sub>), 3.82 (s, 3H, OCH<sub>3</sub>), 6.88 (d,  $J = 8.7$  Hz, 2H, Ar-*H*), 7.42 (d,  $J = 8.7$  Hz, 2H, Ar-*H*);  $^{13}C$  NMR (125 MHz,  $CDCl_3$ )  $\delta$  2.0 (CH<sub>3</sub>), 27.8 (CH<sub>3</sub>), 43.7 (CH<sub>2</sub>), 52.6 (CH<sub>3</sub>), 55.3 (CH<sub>3</sub>), 80.7 (C), 91.0 (C), 113.3 (CH), 124.3 (C), 125.8 (C), 130.3 (CH), 160.1 (C), 160.7 (C), 162.0 (C), 172.8 (C); HRMS (ESI)  $m/z$   $[M + Na]^+$  calcd for  $C_{21}H_{30}O_6SSiNa$  461.1425; found 461.1443.

**Di-tert-butyl (2R)-5-(4-Methoxyphenyl)-2-(tert-butyldiphenylsilyloxy)methyl-3-(trimethylsilyloxy)-2,3-dihydrofuran-3,4-dicarboxylate (2).** The reaction was performed according to the typical procedure (0.3 mL  $CH_2Cl_2$ , 20 °C, 3.5 h) employing  $\alpha$ -diazo ester **1** (27.5 mg, 37.5  $\mu$ mol) and DDQ (12.3 mg, 54.1  $\mu$ mol). Dihydrofuran **2** (17.6 mg, 67%) was obtained as a colorless oil from the crude product (40.2 mg, pale yellow oil) after flash column chromatography (silica gel 2 g, 100:1 → 50:1 *n*-hexane/AcOEt).  $R_f$  0.61 (5:1 *n*-hexane/AcOEt);  $[\alpha]_D^{21} -22.5$  (*c* 0.43,  $CHCl_3$ ); IR (neat) 2961, 2932, 2859, 1752, 1686, 1609, 1508, 1368, 1257, 1175, 1103, 1032  $cm^{-1}$ ;  $^1H$  NMR (500 MHz,  $CDCl_3$ ; spectrum contains a mixture of diastereomers, only the major isomer signals are reported)  $\delta$  0.01 (s, 9H, Si( $CH_3$ )<sub>3</sub>), 1.07 (s, 9H, Si( $CH_3$ )<sub>3</sub>), 1.39 (s, 9H,  $CO_2C(CH_3)_3$ ), 1.45 (s, 9H,  $CO_2C(CH_3)_3$ ), 3.86 (s, 3H,  $C_6H_4OCH_3$ ), 3.90 (dd,  $J = 7.9, 11.8$  Hz, 1H, one of TBDPSOCH<sub>2</sub>), 4.02 (dd,  $J = 4.0, 11.8$  Hz, 1H, one of TBDPSOCH<sub>2</sub>), 4.83 (dd,  $J = 4.0, 7.9$  Hz, 1H, one of OCH), 6.91 (d,  $J = 8.9$  Hz, 2H, Ar-*H*), 7.30–7.41 (m, 6H, Ar-*H*), 7.66–7.70 (m, 6H, Ar-*H*);  $^{13}C$  NMR (125 MHz,  $CDCl_3$ ; spectrum contains a mixture of diastereomers, only the major isomer signals are reported)  $\delta$  1.83 (CH<sub>3</sub>), 19.3 (C), 26.9 (CH<sub>3</sub>), 28.0 (CH<sub>3</sub>), 28.2 (CH<sub>3</sub>), 55.4 (CH<sub>3</sub>), 62.3 (CH<sub>2</sub>), 80.4 (C), 81.5 (C), 86.1 (C), 89.9 (CH), 109.2 (C), 112.9 (CH), 122.2 (C), 127.57 (CH), 127.64 (CH), 129.56 (CH), 129.61 (CH), 131.8 (CH), 133.4 (C), 133.5 (C), 135.6 (CH), 135.7 (CH), 161.6 (C), 163.3 (C), 167.6 (C), 170.1 (C); HRMS (ESI)  $m/z$   $[M + Na]^+$  calcd for  $C_{41}H_{56}O_8Si_2Na$  755.3406; found 755.3394.

**tert-Butyl 3-Cyano-2-diazo-4-[(4-methoxybenzyl)oxy]-3-[(trimethylsilyloxy)]butanoate (6p).** TMSCN (0.24 mL, 1.92 mmol) was added to a mixture of  $\alpha$ -diazo- $\beta$ -ketoester **5** (123 mg, 0.384 mmol) and DABCO (4.3 mg, 38  $\mu$ mol) in  $CH_2Cl_2$  (0.4 mL). After 14 h of stirring, the volatile elements were removed in vacuo, and the brown residue was purified by column chromatography (silica gel 5 g, 5:1 *n*-

hexane/AcOEt) to give cyanide **6p** (146 mg, 91%) as a pale yellow oil.  $R_f$  0.48 (5:1 *n*-hexane/AcOEt); IR (neat) 2976, 2106, 1694, 1614, 1514, 1369, 1323, 1254, 1150, 1117, 1036, 847  $\text{cm}^{-1}$ ;  $^1\text{H}$  NMR (500 MHz,  $\text{CDCl}_3$ )  $\delta$  0.25 (s, 9H,  $\text{Si}(\text{CH}_3)_3$ ), 1.48 (s, 9H,  $\text{CO}_2\text{C}(\text{CH}_3)_3$ ), 3.70 (d,  $J = 10.1$  Hz, 1H, one of  $\text{PMBOCH}_2$ ), 3.80 (s, 3H,  $\text{C}_6\text{H}_4\text{OCH}_3$ ), 3.86 (d,  $J = 10.1$  Hz, 1H, one of  $\text{PMBOCH}_2$ ), 4.59 (s, 2H,  $\text{PMPCH}_2\text{O}$ ), 6.88 (d,  $J = 8.7$  Hz, 2H, Ar-*H*), 7.26 (d,  $J = 8.7$  Hz, 2H, Ar-*H*);  $^{13}\text{C}$  NMR (125 MHz,  $\text{CDCl}_3$ )  $\delta$  0.8 ( $\text{CH}_3$ ), 28.2 ( $\text{CH}_3$ ), 55.2 ( $\text{CH}_3$ ), 68.8 (C), 73.2 ( $\text{CH}_2$ ), 73.5 ( $\text{CH}_2$ ), 82.9 (C), 113.8 (CH), 117.6 (C), 129.0 (C), 129.5 (CH), 159.4 (C), 162.7 (C); HRMS (ESI)  $m/z$   $[\text{M} + \text{Na}]^+$  calcd for  $\text{C}_{20}\text{H}_{29}\text{N}_3\text{O}_5\text{SiNa}$  442.1769; found 442.1758.

**tert-Butyl 2-Diazo-4-[(4-methoxybenzyl)oxy]-3-[(trimethylsilyl)oxy]butanoate (6q).** TMSCl (0.10 mL, 0.788 mmol) was added to an ice-cooled (0 °C) mixture of alcohol **8** (203 mg, 0.629 mmol) and  $\text{Et}_3\text{N}$  (0.26 mL, 1.87 mmol) in  $\text{CH}_2\text{Cl}_2$  (3 mL). After 20 min of stirring at room temperature, the reaction was quenched with saturated aqueous  $\text{NH}_4\text{Cl}$  (10 mL) at 0 °C, and the resulting mixture was extracted with AcOEt (3  $\times$  10 mL). The combined organic extracts were washed with brine (15 mL) and dried over anhydrous  $\text{Na}_2\text{SO}_4$ . Filtration and evaporation in vacuo furnished the crude product (266 mg, pale yellow oil), which was purified by column chromatography (silica gel 15 g, 10:1 *n*-hexane/AcOEt) to give TMS ether **6q** (196 mg, 76%) as a pale yellow oil.  $R_f$  0.50 (5:1 *n*-hexane/AcOEt); IR (neat) 2957, 2091, 1694, 1514, 1368, 1300, 1250, 1173, 1132, 1084, 1038, 845  $\text{cm}^{-1}$ ;  $^1\text{H}$  NMR (500 MHz,  $\text{CDCl}_3$ )  $\delta$  0.14 (s, 9H,  $\text{Si}(\text{CH}_3)_3$ ), 1.47 (s, 9H,  $\text{CO}_2\text{C}(\text{CH}_3)_3$ ), 3.51 (dd,  $J = 5.5, 10.4$  Hz, 1H, one of  $\text{PMBOCH}_2$ ), 3.54 (dd,  $J = 5.5, 10.4$  Hz, 1H, one of  $\text{PMBOCH}_2$ ), 3.81 (s, 3H,  $\text{C}_6\text{H}_4\text{OCH}_3$ ), 4.50 (s, 2H,  $\text{PMPCH}_2\text{O}$ ), 4.74 (t,  $J = 5.5$  Hz, 1H,  $\text{CH}_2\text{CHOTMS}$ ), 6.87 (d,  $J = 8.8$  Hz, 2H, Ar-*H*), 7.25 (d,  $J = 8.8$  Hz, 2H, Ar-*H*);  $^{13}\text{C}$  NMR (125 MHz,  $\text{CDCl}_3$ )  $\delta$  -0.3 ( $\text{CH}_3$ ), 28.3 ( $\text{CH}_3$ ), 55.1 ( $\text{CH}_3$ ), 60.1 (C), 65.9 (CH), 72.0 ( $\text{CH}_2$ ), 72.9 ( $\text{CH}_2$ ), 81.2 (C), 113.6 (CH), 129.1 (CH), 130.0 (C), 159.1 (C), 165.0 (C); HRMS (ESI)  $m/z$   $[\text{M} + \text{Na}]^+$  calcd for  $\text{C}_{19}\text{H}_{30}\text{N}_2\text{O}_5\text{SiNa}$  417.1816; found 417.1819.

**tert-Butyl 2-Diazo-4-[(4-methoxybenzyl)oxy]-3-methyl-3-[(trimethylsilyl)oxy]butanoate (6r).** LDA [prepared from diisopropylamine (0.10 mL, 0.717 mmol) and BuLi in *n*-hexane (1.51 M, 0.47 mL, 0.71 mmol)] in THF (2.5 mL) was added to a cooled (-78 °C) mixture of 1-[(4-methoxybenzyl)oxy]propan-2-one<sup>30</sup> (80.0 mg, 0.412 mmol) and *tert*-butyl diazoacetate (70  $\mu\text{L}$ , 0.505 mmol) in THF (2.5 mL). After 3 h of stirring, the reaction was quenched with saturated aqueous  $\text{NH}_4\text{Cl}$  (10 mL), and the resulting mixture was partitioned between AcOEt (17 mL) and  $\text{H}_2\text{O}$  (5 mL). The aqueous layer was extracted with AcOEt (2  $\times$  7 mL), and the combined organic extracts were washed with brine (10 mL) and dried over anhydrous  $\text{Na}_2\text{SO}_4$ . Filtration and evaporation in vacuo furnished the crude product (138 mg, brown oil), which was purified by column chromatography (silica gel 5 g, 5:1 *n*-hexane/AcOEt) to give the coupling product (75.5 mg, 54%) as a yellow oil.  $R_f$  0.37 (5:1 *n*-hexane/AcOEt); IR (neat) 3482, 2978, 2936, 2864, 2093, 1682, 1614, 1514, 1456, 1369, 1323, 1248, 1173, 1157, 1082, 1036, 820, 748  $\text{cm}^{-1}$ ;  $^1\text{H}$  NMR (500 MHz,

CDCl<sub>3</sub>)  $\delta$  1.44 (s, 3H, CH<sub>3</sub>COH), 1.47 (s, 9H, CO<sub>2</sub>C(CH<sub>3</sub>)<sub>3</sub>), 3.51 (d,  $J$  = 9.2 Hz, 1H, one of PMBOCH<sub>2</sub>), 3.53 (d,  $J$  = 9.2 Hz, 1H, one of PMBOCH<sub>2</sub>), 3.80 (s, 3H, C<sub>6</sub>H<sub>4</sub>OCH<sub>3</sub>), 4.09 (br s, 1H, OH), 4.48 (d,  $J$  = 11.8 Hz, 1H, one of PMPCH<sub>2</sub>O), 4.51 (d,  $J$  = 11.8 Hz, 1H, one of PMPCH<sub>2</sub>O), 6.87 (d,  $J$  = 8.7 Hz, 2H, Ar-*H*), 7.23 (d,  $J$  = 8.7 Hz, 2H, Ar-*H*); <sup>13</sup>C NMR (125 MHz, CDCl<sub>3</sub>)  $\delta$  23.5 (CH<sub>3</sub>), 28.3 (CH<sub>3</sub>), 55.2 (CH<sub>3</sub>), 70.2 (C), 73.0 (CH<sub>2</sub>), 75.1 (CH<sub>2</sub>), 81.9 (C), 113.7 (CH), 129.2 (CH), 129.9 (C), 159.2 (C), 166.6 (C); HRMS (ESI)  $m/z$  [M + Na]<sup>+</sup> calcd for C<sub>17</sub>H<sub>24</sub>N<sub>2</sub>O<sub>5</sub>Na 359.1577; found 359.1586.

HMDS (0.12 mL, 0.575 mmol) and imidazole (20.5 mg, 0.301 mmol) were added to a stirred solution of the coupling product (67.5 mg, 0.201 mmol) in THF (2 mL). After 7 h of heating under reflux, the volatile elements were removed in vacuo, and the pale yellow residue was purified by column chromatography (silica gel 8 g, 10:1 *n*-hexane/AcOEt) to give TMS ether **6r** (70.2 mg, 86%) as a pale yellow oil.  $R_f$  0.62 (5:1 *n*-hexane/AcOEt); IR (neat) 2976, 2093, 1694, 1614, 1514, 1368, 1319, 1250, 1067, 1038, 843 cm<sup>-1</sup>; <sup>1</sup>H NMR (500 MHz, CDCl<sub>3</sub>)  $\delta$  0.12 (s, 9H, Si(CH<sub>3</sub>)<sub>3</sub>), 1.46 (s, 9H, CO<sub>2</sub>C(CH<sub>3</sub>)<sub>3</sub>), 1.52 (s, 3H, CH<sub>3</sub>COTMS), 3.47 (d,  $J$  = 9.6 Hz, 1H, one of PMBOCH<sub>2</sub>), 3.65 (d,  $J$  = 9.6 Hz, 1H, one of PMBOCH<sub>2</sub>), 3.80 (s, 3H, C<sub>6</sub>H<sub>4</sub>OCH<sub>3</sub>), 4.46 (d,  $J$  = 11.6 Hz, 1H, one of PMPCH<sub>2</sub>O), 4.49 (d,  $J$  = 11.6 Hz, 1H, one of PMPCH<sub>2</sub>O), 6.87 (d,  $J$  = 8.5 Hz, 2H, Ar-*H*), 7.24 (d,  $J$  = 8.5 Hz, 2H, Ar-*H*); <sup>13</sup>C NMR (125 MHz, CDCl<sub>3</sub>)  $\delta$  1.7 (CH<sub>3</sub>), 25.0 (CH<sub>3</sub>), 28.4 (CH<sub>3</sub>), 55.2 (CH<sub>3</sub>), 64.2 (C), 73.0 (CH<sub>2</sub>), 73.3 (C), 75.5 (CH<sub>2</sub>), 80.9 (C), 113.7 (CH), 129.2 (CH), 130.4 (C), 159.1 (C), 164.8 (C); HRMS (ESI)  $m/z$  [M + Na]<sup>+</sup> calcd for C<sub>20</sub>H<sub>32</sub>N<sub>2</sub>O<sub>5</sub>SiNa 431.1973; found 431.1979.

**tert-Butyl 4-Cyano-2-(4-methoxyphenyl)-4-(trimethylsilyl)oxy-4,5-dihydrofuran-3-carboxylate (14p).** The reaction was performed according to the typical procedure (1.5 mL CH<sub>2</sub>Cl<sub>2</sub>, 20 °C, 6 h) employing  $\alpha$ -diazo ester **6p** (26.5 mg, 63.2  $\mu$ mol) and DDQ (15.8 mg, 69.6  $\mu$ mol). Dihydrofuran **14p** (14.2 mg, 58%) was obtained as a colorless oil from the crude product (27.4 mg, light brown oil) after column chromatography (twice, silica gel 5 g, 8:1 *n*-hexane/AcOEt; Bio-Beads S-X3, toluene).  $R_f$  0.50 (5:1 *n*-hexane/AcOEt); IR (neat) 2976, 1694, 1614, 1514, 1368, 1252, 1161, 1119, 1028, 968, 845 cm<sup>-1</sup>; <sup>1</sup>H NMR (500 MHz, CDCl<sub>3</sub>)  $\delta$  0.23 (s, 9H, Si(CH<sub>3</sub>)<sub>3</sub>), 1.53 (s, 9H, CO<sub>2</sub>C(CH<sub>3</sub>)<sub>3</sub>), 3.85 (s, 3H, C<sub>6</sub>H<sub>4</sub>OCH<sub>3</sub>), 4.56 (d,  $J$  = 11.0 Hz, 1H, one of OCH<sub>2</sub>), 4.72 (d,  $J$  = 11.0 Hz, 1H, one of OCH<sub>2</sub>), 6.93 (d,  $J$  = 8.9 Hz, 2H, Ar-*H*), 7.81 (d,  $J$  = 8.9 Hz, 2H, Ar-*H*); <sup>13</sup>C NMR (125 MHz, CDCl<sub>3</sub>)  $\delta$  1.2 (CH<sub>3</sub>), 28.2 (CH<sub>3</sub>), 55.3 (CH<sub>3</sub>), 76.7 (C), 81.4 (C), 81.7 (CH<sub>2</sub>), 105.8 (C), 113.3 (CH), 119.0 (C), 120.5 (C), 131.7 (CH), 162.2 (C), 162.3 (C), 169.5 (C); HRMS (ESI)  $m/z$  [M + Na]<sup>+</sup> calcd for C<sub>20</sub>H<sub>27</sub>NO<sub>5</sub>SiNa 412.1551; found 412.1537.

**tert-Butyl (2S\*,3R\*)-2-(4-Methoxyphenyl)-4-oxotetrahydrofuran-3-carboxylate (15q).** A solution of  $\alpha$ -diazo ester **6q** (50.3 mg, 127  $\mu$ mol) in CH<sub>2</sub>Cl<sub>2</sub> (0.8 mL) was added to a cooled (-30 °C) suspension of DDQ (43.4 mg, 191  $\mu$ mol) in CH<sub>2</sub>Cl<sub>2</sub> (0.5 mL). After 43 h of stirring, the reaction was quenched by addition of a 1:1 mixture of saturated aqueous NaHCO<sub>3</sub> and 1 M aqueous Na<sub>2</sub>S<sub>2</sub>O<sub>3</sub> (2 mL), and the resulting mixture was extracted with 3:1 *n*-hexane/AcOEt (10 mL). The organic extract was successively washed

with saturated aqueous NaHCO<sub>3</sub>/1 M aqueous Na<sub>2</sub>S<sub>2</sub>O<sub>3</sub> (1:1, 2 × 4 mL) and brine (2 × 4 mL), and dried over anhydrous Na<sub>2</sub>SO<sub>4</sub>. Filtration and evaporation in vacuo followed by flash column chromatography (silica gel 2 g, 40:1 → 20:1 *n*-hexane/AcOEt) afforded β-ketoester **15q** (12.9 mg, 35%) as a white solid. *R*<sub>f</sub> 0.40 (5:1 *n*-hexane/AcOEt); mp 91–92 °C (colorless needles from *n*-hexane); IR (KBr) 2976, 1773, 1721, 1614, 1518, 1342, 1281, 1254, 1177, 1167, 1123, 1107, 1030, 833 cm<sup>-1</sup>; <sup>1</sup>H NMR (500 MHz, CDCl<sub>3</sub>) δ 1.46 (s, 9H, CO<sub>2</sub>C(CH<sub>3</sub>)<sub>3</sub>), 3.33 (d, *J* = 10.3 Hz, 1H, CHCO<sub>2</sub>*t*-Bu), 3.82 (s, 3H, C<sub>6</sub>H<sub>4</sub>OCH<sub>3</sub>), 4.11 (d, *J* = 17.0 Hz, 1H, one of OCH<sub>2</sub>), 4.34 (d, *J* = 17.0 Hz, 1H, one of OCH<sub>2</sub>), 5.39 (d, *J* = 10.3 Hz, 1H, PMPCHO), 6.93 (d, *J* = 8.6 Hz, 2H, Ar-*H*), 7.34 (d, *J* = 8.6 Hz, 2H, Ar-*H*); <sup>13</sup>C NMR (125 MHz, CDCl<sub>3</sub>) δ 28.0 (CH<sub>3</sub>), 55.3 (CH<sub>3</sub>), 62.3 (CH), 72.1 (CH<sub>2</sub>), 82.0 (CH), 82.9 (C), 108.4 (C), 114.1 (CH), 127.3 (CH), 130.6 (C), 159.8 (C), 165.6 (C), 207.8 (C); HRMS (ESI) *m/z* [M + Na]<sup>+</sup> calcd for C<sub>16</sub>H<sub>20</sub>O<sub>5</sub>Na 315.1203; found 315.1217.

**tert-Butyl (2*R*\*,3*S*\*)-2-(4-Methoxyphenyl)-3-methyl-4-oxotetrahydrofuran-3-carboxylate (15r).** A solution of α-diazo ester **6r** (55.7 mg, 136 μmol) in CH<sub>2</sub>Cl<sub>2</sub> (0.6 mL) was added to a cooled (-30 °C) suspension of DDQ (46.4 mg, 204 μmol) in CH<sub>2</sub>Cl<sub>2</sub> (0.4 mL). After 24 h of stirring, the reaction was quenched by addition of a 1:1 mixture of saturated aqueous NaHCO<sub>3</sub> and 1 M aqueous Na<sub>2</sub>S<sub>2</sub>O<sub>3</sub> (2 mL), and the resulting mixture was extracted with 3:1 *n*-hexane/AcOEt (10 mL). The organic extract was successively washed with saturated aqueous NaHCO<sub>3</sub>/1 M aqueous Na<sub>2</sub>S<sub>2</sub>O<sub>3</sub> (1:1, 2 × 4 mL) and brine (2 × 4 mL), and dried over anhydrous Na<sub>2</sub>SO<sub>4</sub>. Filtration and evaporation in vacuo furnished the crude product (15.3 mg, brown oil), which was purified by flash column chromatography (silica gel 2 g, 40:1 *n*-hexane/AcOEt) to give β-ketoester **15r** (8.6 mg, 21%) as a colorless oil. *R*<sub>f</sub> 0.35 (5:1 *n*-hexane/AcOEt); IR (KBr) 2980, 1771, 1734, 1616, 1516, 1458, 1369, 1252, 1159, 1080, 1034 cm<sup>-1</sup>; <sup>1</sup>H NMR (500 MHz, CDCl<sub>3</sub>) δ 1.23 (s, 9H, CO<sub>2</sub>C(CH<sub>3</sub>)<sub>3</sub>), 1.40 (s, 3H, CH<sub>3</sub>CCO), 3.81 (s, 3H, C<sub>6</sub>H<sub>4</sub>OCH<sub>3</sub>), 4.09 (d, *J* = 17.1 Hz, 1H, one of OCH<sub>2</sub>), 4.55 (d, *J* = 17.1 Hz, 1H, one of OCH<sub>2</sub>), 4.90 (s, 1H, PMPCHO), 6.90 (d, *J* = 8.7 Hz, 2H, Ar-*H*), 7.35 (d, *J* = 8.7 Hz, 2H, Ar-*H*); <sup>13</sup>C NMR (125 MHz, CDCl<sub>3</sub>) δ 16.2 (CH<sub>3</sub>), 27.7 (CH<sub>3</sub>), 55.3 (CH<sub>3</sub>), 60.1 (C), 71.6 (CH<sub>2</sub>), 82.6 (C), 88.3 (CH<sub>2</sub>), 113.6 (CH), 127.1 (CH), 128.3 (C), 159.7 (C), 167.1 (C), 212.6 (C); HRMS (ESI) *m/z* [M + Na]<sup>+</sup> calcd for C<sub>17</sub>H<sub>22</sub>O<sub>5</sub>Na 329.1359; found 329.1370.

**Methyl 2-(4-Methoxyphenyl)benzofuran-3-carboxylate (18).**<sup>31</sup> The reaction was performed according to the typical procedure (0.9 mL CH<sub>2</sub>Cl<sub>2</sub>, 20 °C, 6 h) employing α-diazo ester **17**<sup>29</sup> (45.5 mg, 146 μmol) and DDQ (49.6 mg, 219 μmol). Benzofuran **18** (6.5 mg, 16%) was obtained as a yellow oil, along with hydroquinone adduct **19** (13.1 mg, 22%) as a colorless oil, from the crude product (53.5 mg, yellow oil) after column chromatography (silica gel 2 g, 40:1 → 1:1 *n*-hexane/AcOEt). *R*<sub>f</sub> 0.35 (5:1 *n*-hexane/AcOEt); IR (neat) 2951, 2930, 2839, 1716, 1609, 1506, 1452, 1261, 1226, 1179, 1088, 1049, 1030, 908, 851, 789, 734 cm<sup>-1</sup>; <sup>1</sup>H NMR (500 MHz, CDCl<sub>3</sub>) δ 3.89 (s, 3H, OCH<sub>3</sub>), 3.95 (s, 3H, OCH<sub>3</sub>), 7.01 (d, *J* = 9.0 Hz, 2H, Ar-*H*), 7.35 (m, 2H, Ar-*H*), 7.52 (m, 1H, Ar-*H*), 8.03–8.06 (m, 3H, Ar-*H*); <sup>13</sup>C NMR (125

MHz, CDCl<sub>3</sub>)  $\delta$  51.5 (CH<sub>3</sub>), 55.4 (CH<sub>3</sub>), 107.5 (C), 110.0 (CH), 113.6 (CH), 122.0 (C), 122.5 (CH), 123.9 (CH), 124.9 (CH), 127.2 (C), 131.1 (CH), 153.5 (C), 161.1 (C), 161.2 (C), 164.7 (C); HRMS (ESI)  $m/z$  [M + Na]<sup>+</sup> calcd for C<sub>17</sub>H<sub>14</sub>O<sub>4</sub>Na 305.0790; found 305.0786.

**Dimethyl 2,2'-(2,3-Dichloro-5,6-dicyano-1,4-phenylenedioxy)bis(2-(4-methoxybenzyl)oxyphenylacetate) (19).**  $R_f$  0.19 (3:1 *n*-hexane/AcOEt); IR (neat) 2957, 2928, 2253, 1751, 1655, 1638, 1516, 1458, 1437, 1414, 1379, 1246, 1175 cm<sup>-1</sup>; <sup>1</sup>H NMR (500 MHz, CDCl<sub>3</sub>)  $\delta$  3.739 (s, 3H, OCH<sub>3</sub>), 3.741 (s, 3H, OCH<sub>3</sub>), 3.79 (s, 3H, OCH<sub>3</sub>), 3.80 (s, 3H, OCH<sub>3</sub>), 4.81 (d,  $J$  = 10.6 Hz, 1H, one of PMPCH<sub>2</sub>), 4.83 (d,  $J$  = 10.6 Hz, 1H, one of PMPCH<sub>2</sub>), 4.94 (d,  $J$  = 10.6 Hz, 1H, one of PMPCH<sub>2</sub>), 4.95 (d,  $J$  = 10.6 Hz, 1H, one of PMPCH<sub>2</sub>), 6.21 (s, 1H, OCHCO<sub>2</sub>Me), 6.22 (s, 1H, OCHCO<sub>2</sub>Me), 6.88 (m, 4H, Ar-H), 6.96 (m, 2H, Ar-H), 7.01 (m, 2H, Ar-H), 7.17 (m, 4H, Ar-H), 7.39 (m, 4H, Ar-H); <sup>13</sup>C NMR (125 MHz, CDCl<sub>3</sub>)  $\delta$  52.7 (CH<sub>3</sub>), 55.19 (CH<sub>3</sub>), 55.23 (CH<sub>3</sub>), 70.06 (CH<sub>2</sub>), 70.10 (CH<sub>2</sub>), 78.5 (CH), 78.7 (CH), 109.4 (C), 109.7 (C), 111.68 (C), 111.75 (C), 112.1 (CH), 113.96 (CH), 114.00 (CH), 121.1 (CH), 121.2 (CH), 122.3 (C), 122.5 (C), 127.7 (C), 127.8 (C), 129.0 (CH), 129.6 (CH), 129.8 (CH), 131.6 (CH), 131.7 (CH), 134.26 (C), 134.33 (C), 153.3 (C), 153.4 (C), 156.57 (C), 156.60 (C), 159.5 (C), 168.7 (C), 168.8 (C); HRMS (ESI)  $m/z$  [M + Na]<sup>+</sup> calcd for C<sub>42</sub>H<sub>34</sub>O<sub>10</sub>N<sub>2</sub>Cl<sub>2</sub>Na 819.1483; found 819.1492.

## ACKNOWLEDGEMENTS

This research was supported in part by a Grant-in-Aid for Scientific Research from the Japan Society for the Promotion of Science (JSPS) and the Platform Project for Supporting in Drug Discovery and Life Science Research from Japan Agency for Medical Research and Development (AMED). We are grateful to Dr. Kotaro Kikushima and Ms. Ayaka Kimura for assisting in the preparation of substrates. We thank Dr. Kan'ichiro Ishiuchi of the Graduate School of Pharmaceutical Sciences, Nagoya City University for helpful discussion on stereochemical assignments.

## REFERENCES AND NOTES

1. For reviews, see: (a) A. Ford, H. Miel, A. Ring, C. N. Slattery, A. R. Maguire, and M. A. McKerverey, *Chem. Rev.*, 2015, **115**, 9981; (b) K. A. Mix, M. R. Aronoff, and R. T. Raines, *ACS Chem. Biol.*, 2016, **11**, 3233.
2. For reviews, see: (a) T. Hashimoto and K. Maruoka, *Chem. Rev.*, 2015, **115**, 5366; (b) K. V. Gothelf and K. A. Jørgensen, *Chem. Rev.*, 1998, **98**, 863.
3. For a review, see: N. R. Candeias and C. A. M. Afonso, *Curr. Org. Chem.*, 2009, **13**, 763.
4. For reviews, see: (a) Y. Xia, D. Qiu, and J. Wang, *Chem. Rev.*, 2017, **117**, 13810; (b) M. R. Fructos, M. M. Díaz-Requejo, and P. J. Pérez, *Chem. Commun.*, 2016, **52**, 7326; (c) M. P. Doyle, R. Duffy, M. Ratnikov, and L. Zhou, *Chem. Rev.*, 2010, **110**, 704; (d) H. M. L. Davies and J. R. Manning,

[Nature](#), 2008, **451**, 417.

5. For selected examples, see: (a) L. Zhang, X.-H. Meng, P. Liu, J. Chen, and Y.-L. Zhao, [Eur. J. Org. Chem.](#), 2017, **6137**; (b) M. Zhan, S. Zhang, W.-X. Zhang, and Z. Xi, [Org. Lett.](#), 2013, **15**, 4182; (c) F. M. F. Santos, J. N. Rosa, V. André, M. T. Duarte, L. F. Veiros, and P. M. P. Gois, [Org. Lett.](#), 2013, **15**, 1760; (d) W. Li, X. Liu, X. Hao, X. Hu, Y. Chu, W. Cao, S. Qin, C. Hu, L. Lin, and X. Feng, [J. Am. Chem. Soc.](#), 2011, **133**, 15268.
6. For reviews, see: (a) N. R. Candeias, R. Paterna, and P. M. P. Gois, [Chem. Rev.](#), 2016, **116**, 2937; (b) Y. Zhang and J. Wang, [Chem. Commun.](#), 2009, 5350.
7. T. Bug, M. Hartnagel, C. Schlierf, and H. Mayr, [Chem. Eur. J.](#), 2003, **9**, 4068.
8. (a) C. R. Holmquist and E. J. Roskamp, [J. Org. Chem.](#), 1989, **54**, 3258; (b) A. Padwa, S. F. Hornbuckle, Z. Zhang, and L. Zhi, [J. Org. Chem.](#), 1990, **55**, 5297; (c) C. R. Holmquist and E. J. Roskamp, [Tetrahedron Lett.](#), 1992, **33**, 1131; (d) K. Nomura, T. Iida, K. Hori, and E. Yoshii, [J. Org. Chem.](#), 1994, **59**, 488.
9. (a) S. J. Mahmood and M. M. Hossain, [J. Org. Chem.](#), 1998, **63**, 3333; (b) S. Kanemasa, T. Kanai, T. Araki, and E. Wada, [Tetrahedron Lett.](#), 1999, **40**, 5055; (c) M. E. Dudley, M. M. Morshed, C. L. Brennan, M. S. Islam, M. S. Ahmad, M.-R. Atuu, B. Branstetter, and M. M. Hossain, [J. Org. Chem.](#), 2004, **69**, 7599.
10. (a) Z. Zhu and J. H. Espenson, [J. Org. Chem.](#), 1995, **60**, 7090; (b) M. Curini, F. Epifano, M. C. Marcotullio, and O. Rosati, [Eur. J. Org. Chem.](#), 2002, 1562.
11. L. Zhou and M. P. Doyle, [J. Org. Chem.](#), 2009, **74**, 9222.
12. (a) O. Kataoka, S. Kitagaki, N. Watanabe, J. Kobayashi, S. Nakamura, M. Shiro, and S. Hashimoto, [Tetrahedron Lett.](#), 1998, **39**, 2371; (b) S. Nakamura, Y. Hirata, T. Kurosaki, M. Anada, O. Kataoka, S. Kitagaki, and S. Hashimoto, [Angew. Chem. Int. Ed.](#), 2003, **42**, 5351; (c) Y. Hirata, S. Nakamura, N. Watanabe, O. Kataoka, T. Kurosaki, M. Anada, S. Kitagaki, M. Shiro, and S. Hashimoto, [Chem. Eur. J.](#), 2006, **12**, 8898.
13. (a) Y. Oikawa, T. Yoshioka, and O. Yonemitsu, [Tetrahedron Lett.](#), 1982, **23**, 885; (b) K. Horita, T. Yoshioka, T. Tanaka, Y. Oikawa, and O. Yonemitsu, [Tetrahedron](#), 1986, **42**, 3021.
14. For reviews on oxidation by quinones, see: (a) A. E. Wendlandt and S. S. Stahl, [Angew. Chem. Int. Ed.](#), 2015, **54**, 14638; (b) D. Walker and J. D. Hiebert, [Chem. Rev.](#), 1967, **67**, 153.
15. For a preliminary communication, see: H. Kondo, H. Yamakoshi, A. Kimura, and S. Nakamura, [ChemistrySelect](#), 2017, **2**, 5646.
16. (a) A. B. Smith, III and R. J. Fox, [Org. Lett.](#), 2004, **6**, 1477; (b) A. Ilangovan and S. Saravanakumar, [Beilstein J. Org. Chem.](#), 2014, **10**, 127.
17. (a) E. Wenkert and C. A. McPherson, [J. Am. Chem. Soc.](#), 1972, **94**, 8084; (b) U. Schöllkopf, B.

- Bánhidai, H. Frasnelli, R. Meyer, and H. Beckhaus, *Liebigs Ann. Chem.*, 1974, 1767.
18. M. Frigerio and M. Santagostino, *Tetrahedron Lett.*, 1994, **35**, 8019.
  19. Methyl L-(+)-glycerate is commercially available. Alternatively, an inexpensive two-step synthesis from L-serine is amenable to large-scale preparations via deamination followed by esterification. G. Hirth and W. Walther, *Helv. Chim. Acta*, 1985, **68**, 1863.
  20. (a) N. Nagashima and M. Ohno, *Chem. Lett.*, 1987, 141; (b) N. Nagashima and M. Ohno, *Chem. Pharm. Bull.*, 1991, **39**, 1972.
  21. (a) S. Yoshino, K. Hayakawa, and K. Kanematsu, *J. Org. Chem.*, 1981, **46**, 3841; (b) H. Asahi and T. Inabe, *Chem. Mater.*, 1994, **6**, 1875.
  22. Y. Hayashi and T. Mukaiyama, *Chem. Lett.*, 1987, 1811.
  23. For the use of LiClO<sub>4</sub> in the DDQ-promoted oxidative C–C bond formation of PMB ethers, see: B.-P. Ying, B. G. Trogden, D. T. Kohlman, S. X. Liang, and Y.-C. Xu, *Org. Lett.*, 2004, **6**, 1523.
  24. N. Nakajima, R. Abe, and O. Yonemitsu, *Chem. Pharm. Bull.*, 1988, **36**, 4244.
  25. Recently, the mechanism and substituent effects for oxidation of benzyl/allyl ethers by DDQ have been established on the basis of a detailed computational study. C. A. Morales-Rivera, P. E. Floreancig, and P. Liu, *J. Am. Chem. Soc.*, 2017, **139**, 17935.
  26. (a) Y. Oikawa, K. Horita, and O. Yonemitsu, *Tetrahedron Lett.*, 1985, **26**, 1541; (b) Y. Oikawa, T. Tanaka, and O. Yonemitsu, *Tetrahedron Lett.*, 1986, **27**, 3647.
  27. The reaction of  $\alpha$ -diazo ester **1** (dr = 10:1) under the optimized conditions provided 2,3-dihydrofuran **2** in 67% yield.
  28. Monitoring of the reactions by TLC showed that starting materials were completely consumed and that the formation of migration products **15q** and **15r** were accompanied by anisaldehyde and a number of more polar byproducts; however, we could not isolate any more polar byproduct after the aqueous workup.
  29. H. Saito, H. Oishi, S. Kitagaki, S. Nakamura, M. Anada, and S. Hashimoto, *Org. Lett.*, 2002, **4**, 3887.
  30. S. K. Ghosh, M. S. Butler, and M. J. Lear, *Tetrahedron Lett.*, 2012, **53**, 2706.
  31. X. Guo, R. Yu, H. Li, and Z. Li, *J. Am. Chem. Soc.*, 2009, **131**, 17387.